

[54] **END CAP FOR AUTOMOBILE
DIFFERENTIAL**

[76] **Inventor: Carl A. Gentile, 260 Chase Rd.,
Columbus, Ohio 43214**

[**] **Term: 14 Years**

[21] **Appl. No.: 318,314**

[22] **Filed: Nov. 4, 1981**

[52] **U.S. Cl. D15/149; D12/160**

[58] **Field of Search D15/149; 180/76;
74/606 R, 710; D12/160**

[56] **References Cited**

U.S. PATENT DOCUMENTS

D. 205,632	8/1966	Woodward	D15/149
D. 245,610	8/1977	Jones	D15/149
4,162,712	7/1979	Nelson	180/76 X

OTHER PUBLICATIONS

General Motors Parts Identification Flyer, 1963-1979
"Y" Rear Axle Assembly Element #32.

J. C. Whitney 1980 Catalog—p. 36—Differential Covers.

Primary Examiner—Catherine E. Kemper
Attorney, Agent, or Firm—Robert E. Stebens

[57] **CLAIM**

The ornamental design for an end cap for automobile differential, substantially as shown and described.

DESCRIPTION

FIG. 1 is a perspective view of an end cap for automobile differential showing my new design;
FIG. 2 is a front elevational view thereof;
FIG. 3 is a right side elevational view thereof;
FIG. 4 is a left side elevational view thereof;
FIG. 5 is a bottom plan view thereof.

The rear thereof comprises a flat-surfaced, peripheral bolt flange surrounding a cavity, all without ornamentation.

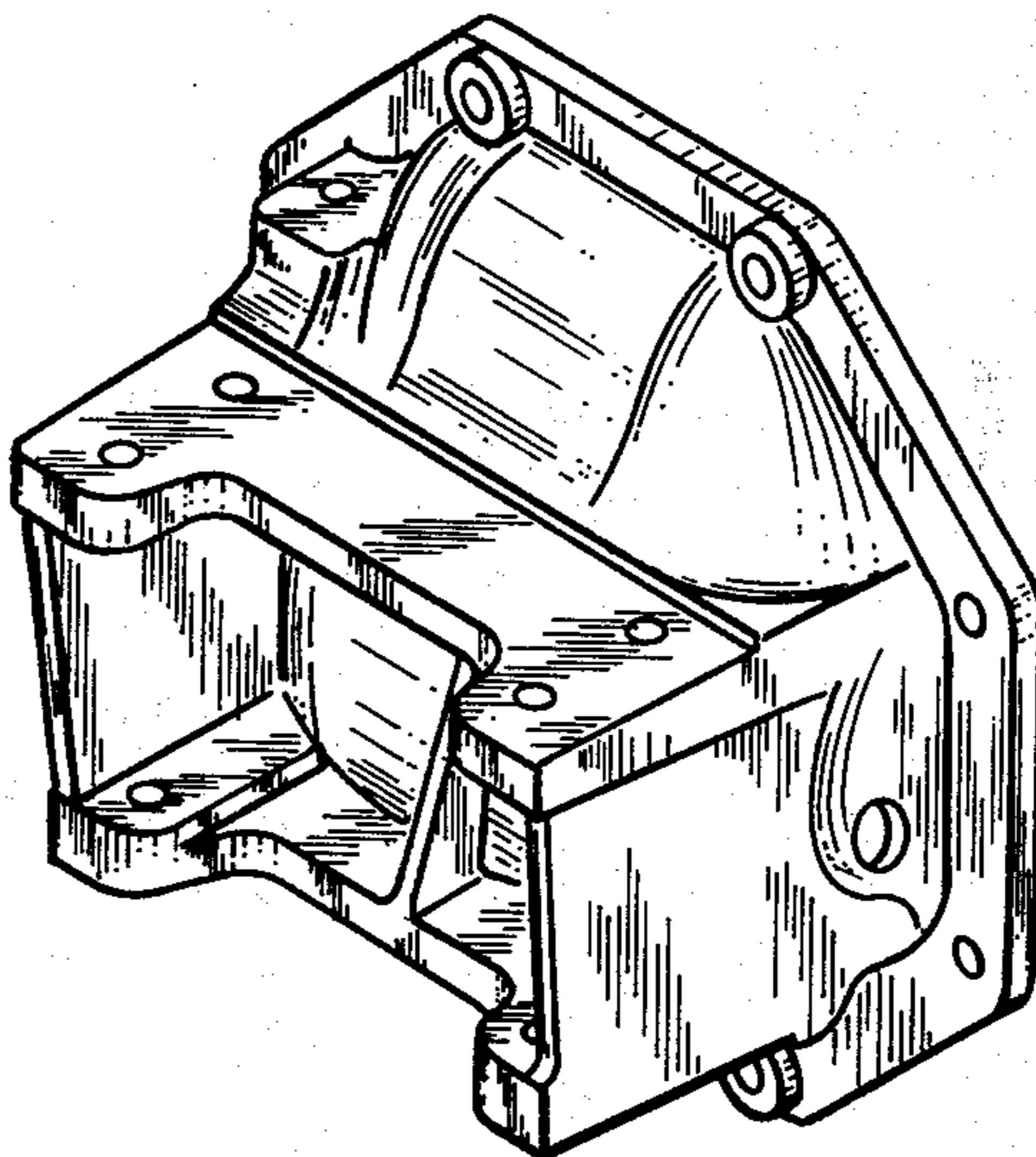

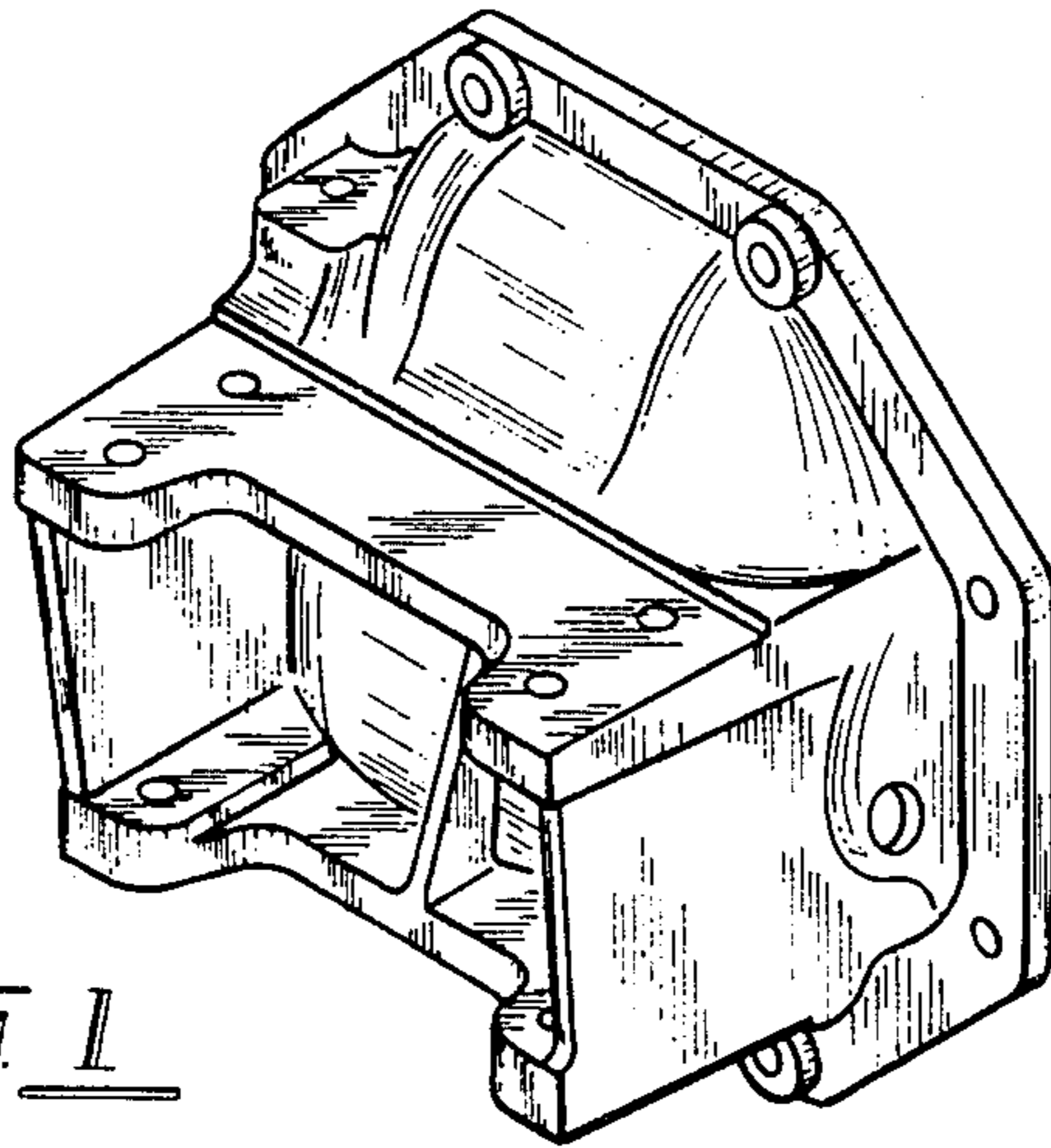

Fig 1

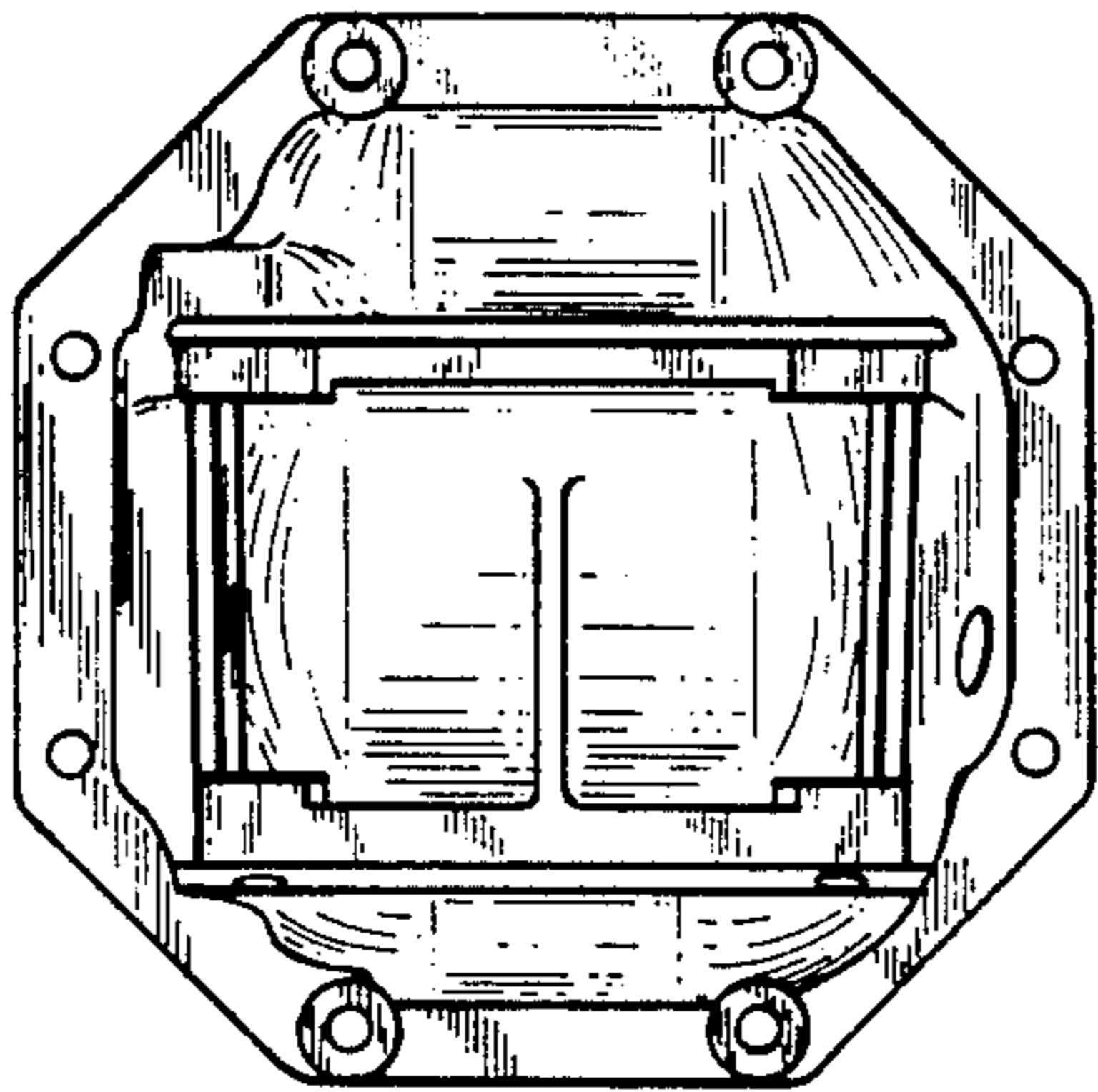

Fig 2

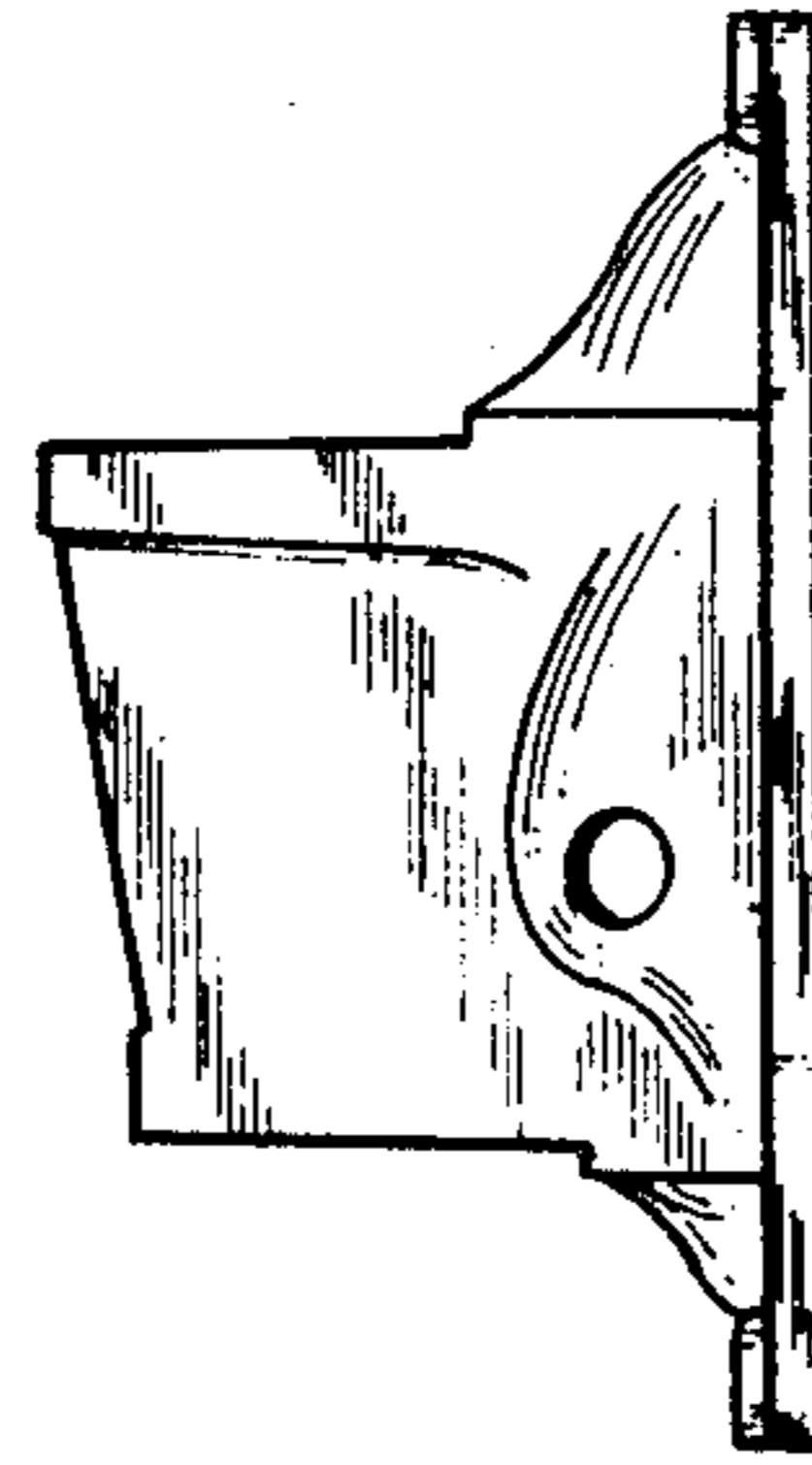

Fig 3

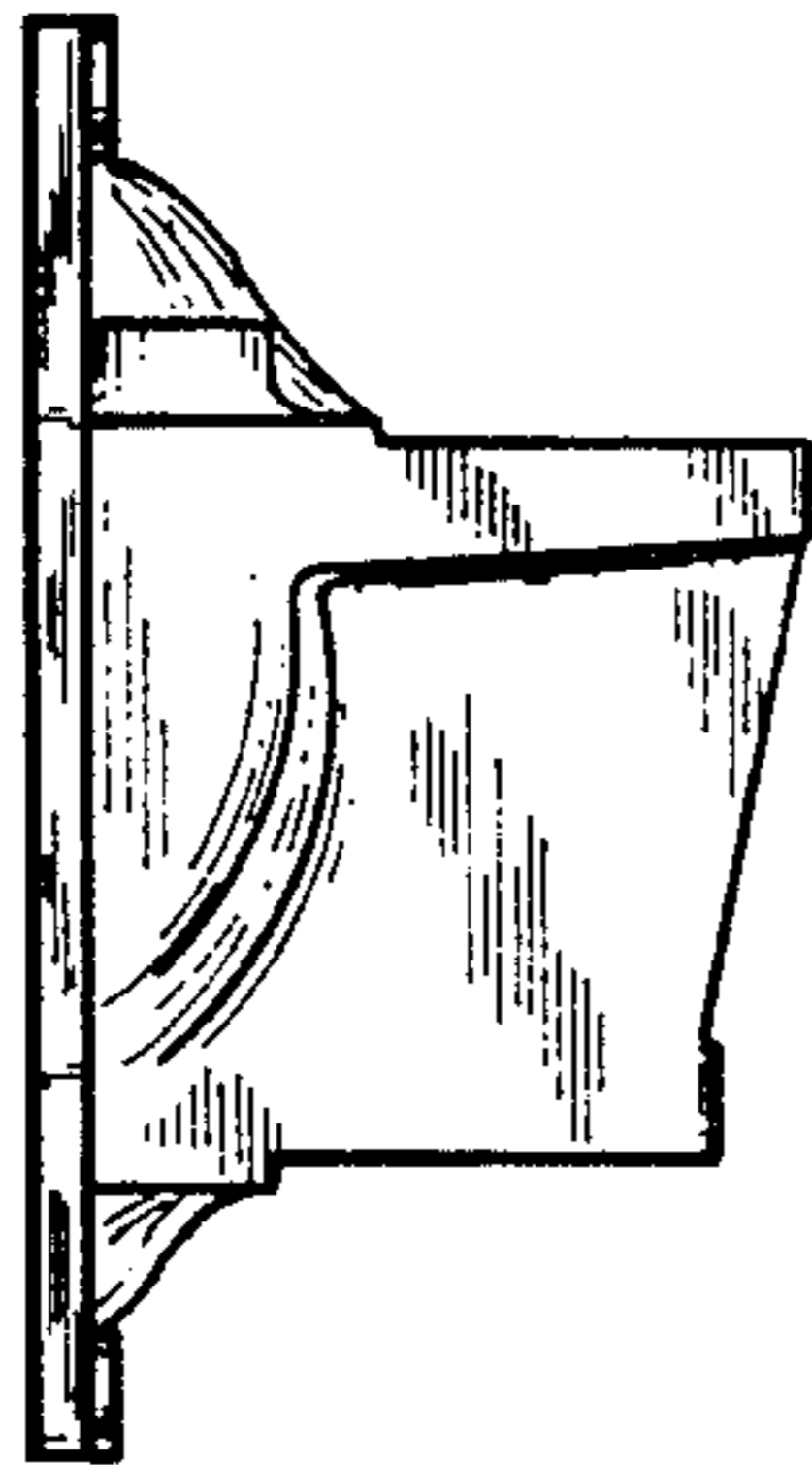

Fig 4

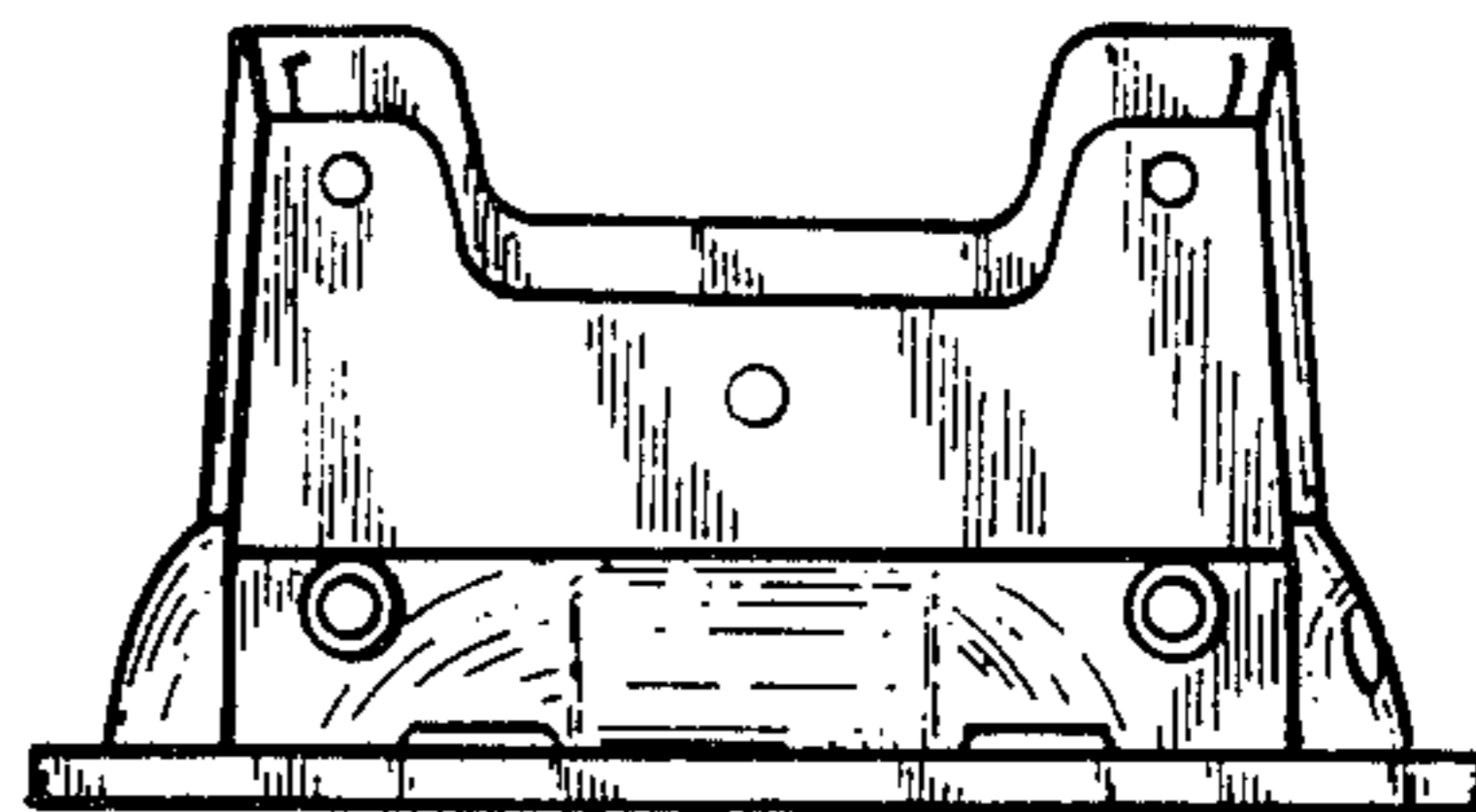

Fig 5