

[54] BOAT MOTOR MOUNT

[76] Inventor: Robert H. Hathorne, 18287 W. 58th Dr., Golden, Colo. 80403

[**] Term: 14 Years

[21] Appl. No.: 598,212

[22] Filed: Apr. 9, 1984

[52] U.S. Cl. D12/317

[58] Field of Search D15/4; D12/317, 318; 248/640, 641, 642, 643; 440/900

[56] References Cited

U.S. PATENT DOCUMENTS

1,690,435	11/1928	Savage	248/641
2,212,675	8/1940	Taylor	248/641
2,439,707	4/1948	Wright	248/641
2,643,837	6/1953	Rivers	248/641
2,808,218	10/1957	Steller	D12/317
3,749,046	7/1973	Ow	248/642
4,077,353	3/1978	Webb, Jr.	248/641
4,306,703	12/1981	Finze	248/642
4,361,102	11/1982	Wood et al.	114/56

FOREIGN PATENT DOCUMENTS

2032372	5/1980	United Kingdom	248/643
---------	--------	----------------------	---------

Primary Examiner—James M. Gandy
Assistant Examiner—Kay H. Chin
Attorney, Agent, or Firm—Norvell E. Von Behren

[57] CLAIM

The ornamental design for a boat motor mount, as shown and described.

DESCRIPTION

FIG. 1 is a perspective view of the boat motor mount showing my new design.

FIG. 2 is a front elevation view, taken along line 2—2 of FIG. 1.

FIG. 3 is a right-side elevation view, taken along line 3—3 of FIG. 2.

FIG. 4 is a top plan view, taken along line 4—4 of FIG. 2.

FIG. 5 is a left-side elevation view, taken along line 5—5 of FIG. 2.

FIG. 6 is a bottom plan view, taken along line 6—6 of FIG. 2.

FIG. 7 is a rear elevation view, taken along line 7—7 of FIG. 1.

FIG. 8 is a perspective view of a second embodiment of the boat motor mount.

FIG. 9 is a front elevation view of the second embodiment shown in FIG. 8, and taken along line 9—9 of FIG. 8.

FIG. 10 is a left-side elevation view, taken along line 10—10 of the second embodiment shown in FIG. 9.

FIG. 11 is a top plan view of the second embodiment, taken along line 11—11 of FIG. 9.

FIG. 12 is a right-side elevation view of the second embodiment, taken along line 12—12 of FIG. 9.

FIG. 13 is a bottom plan view of the second embodiment, taken along line 13—13 of FIG. 9.

FIG. 14 is a rear elevation view of the second embodiment, taken along line 14—14 of FIG. 8.

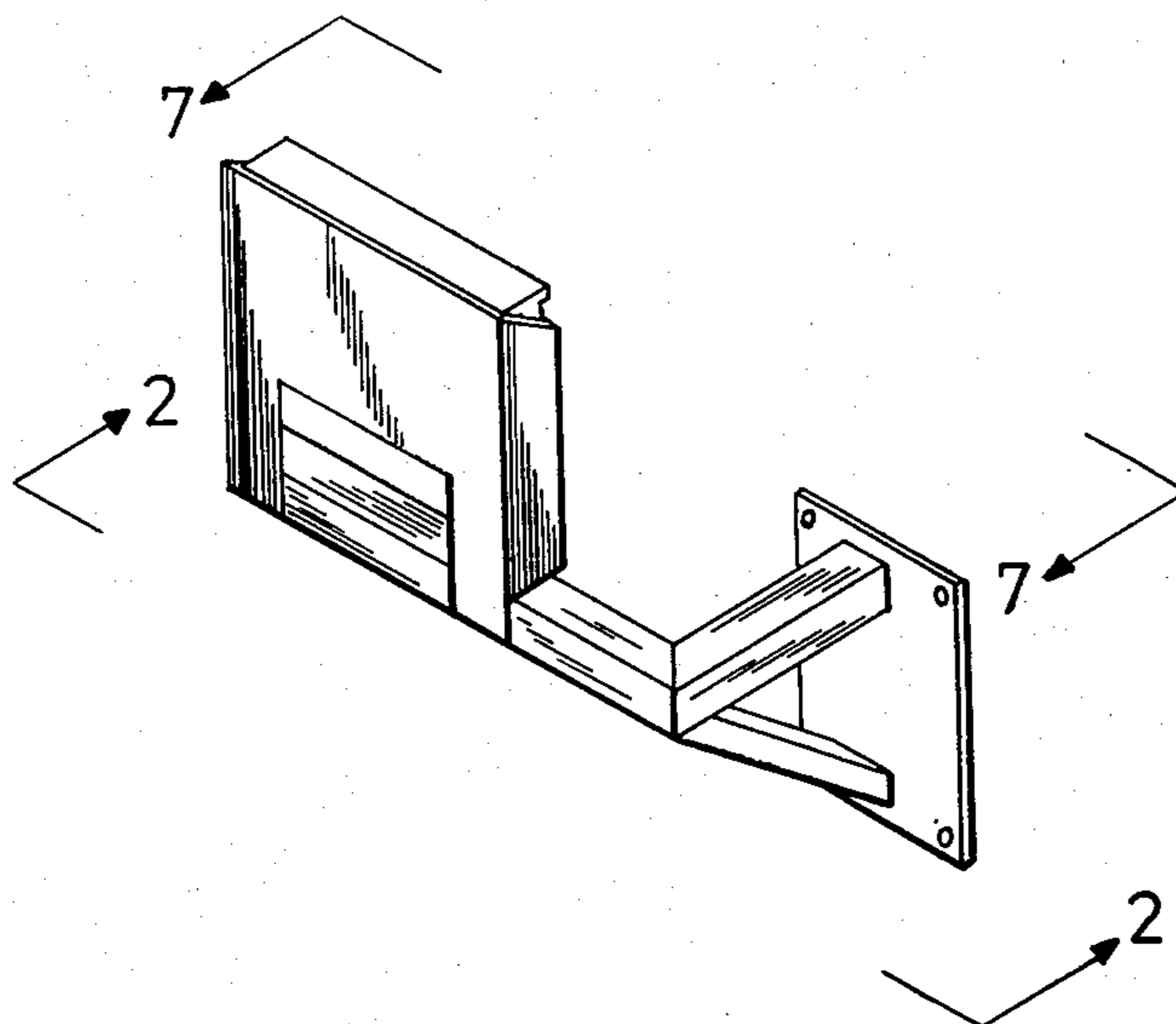

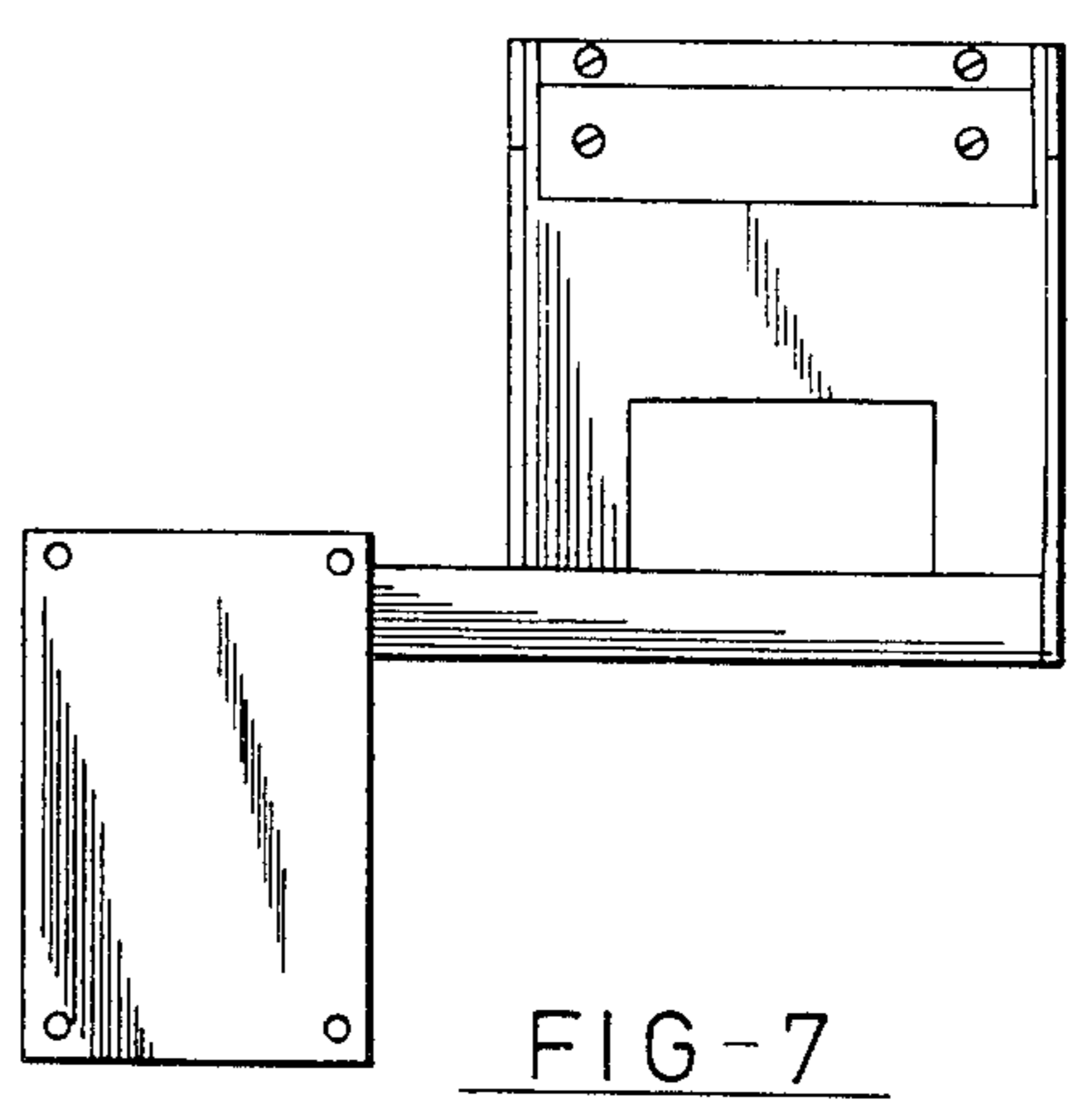
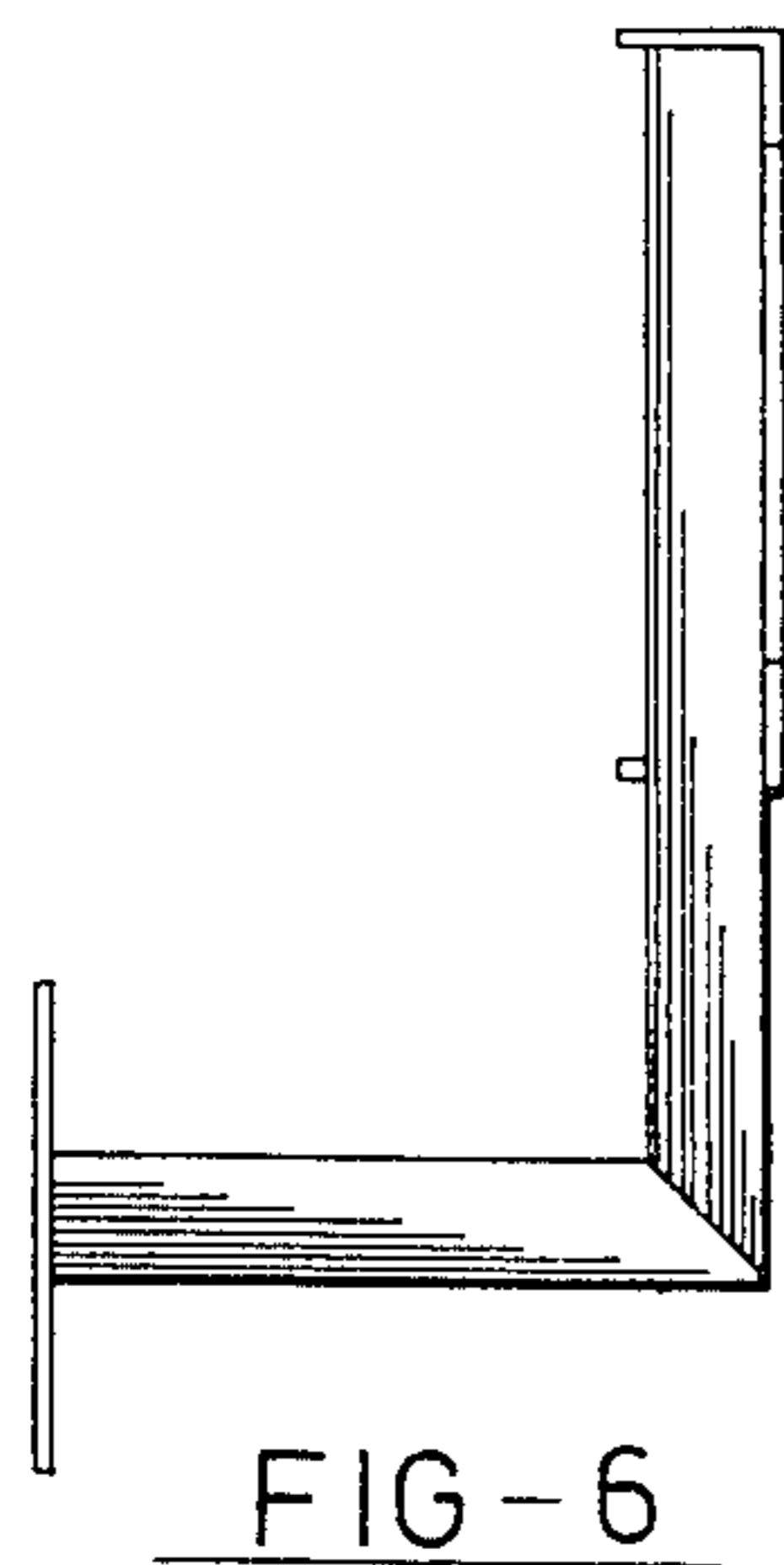
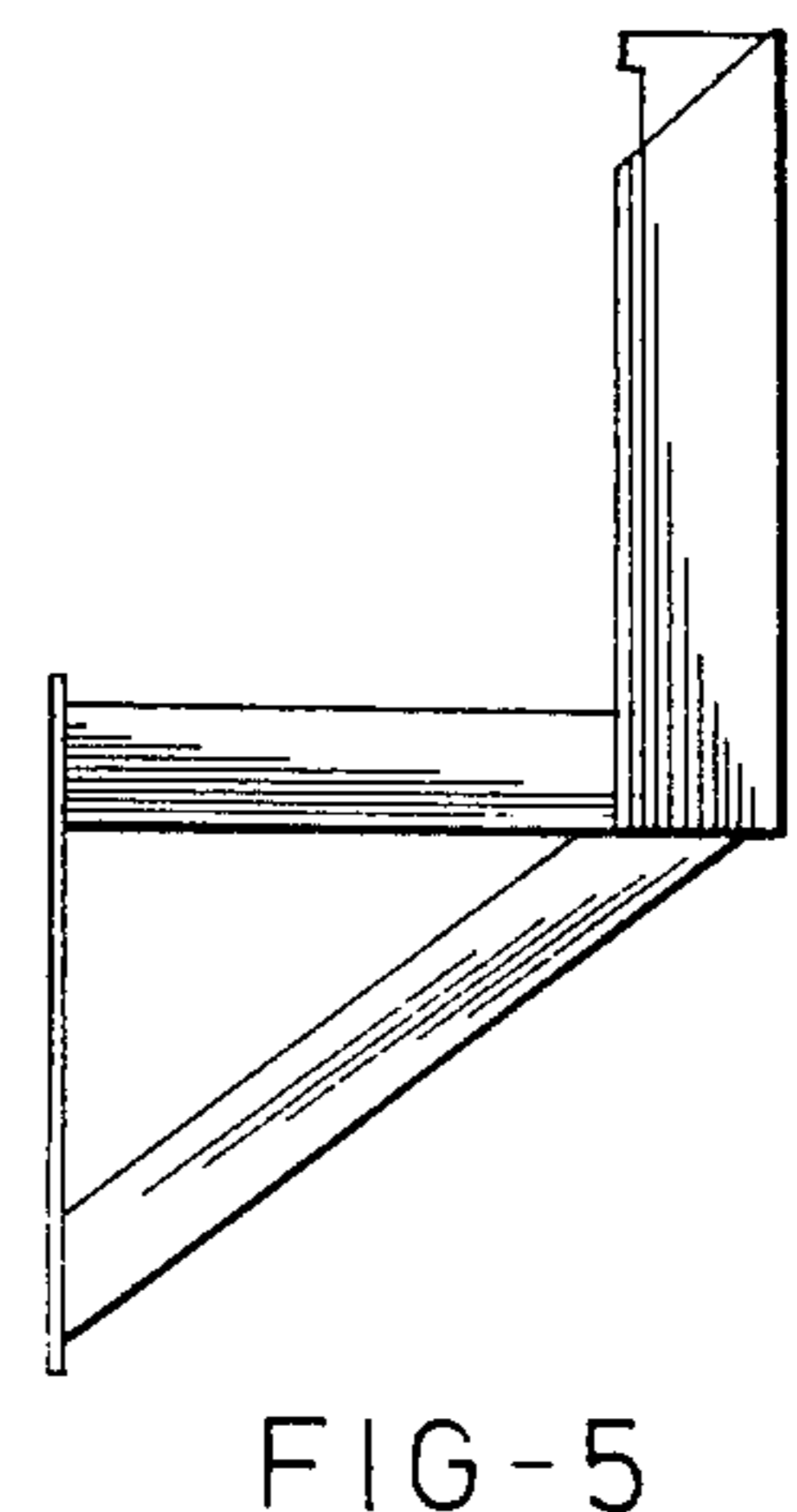
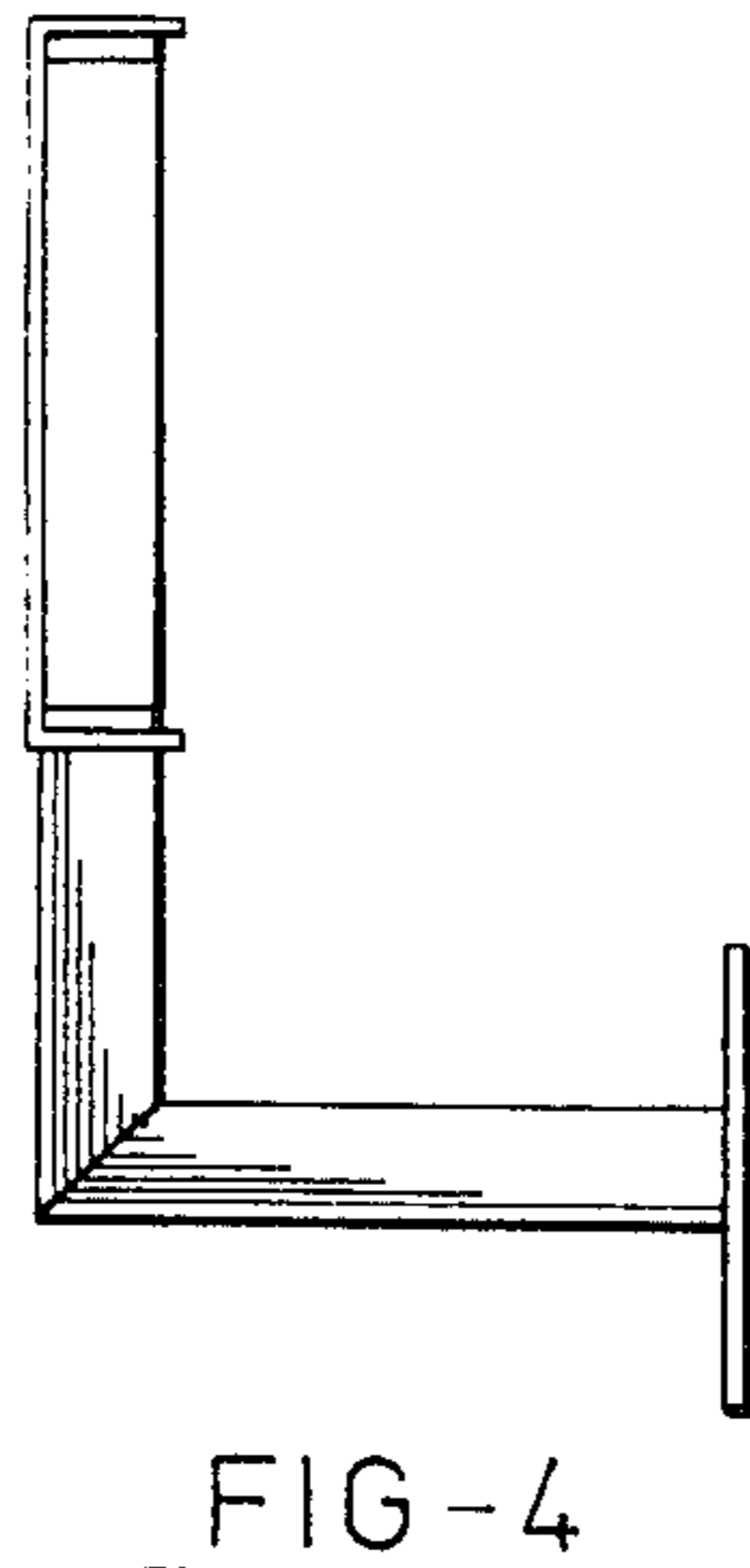
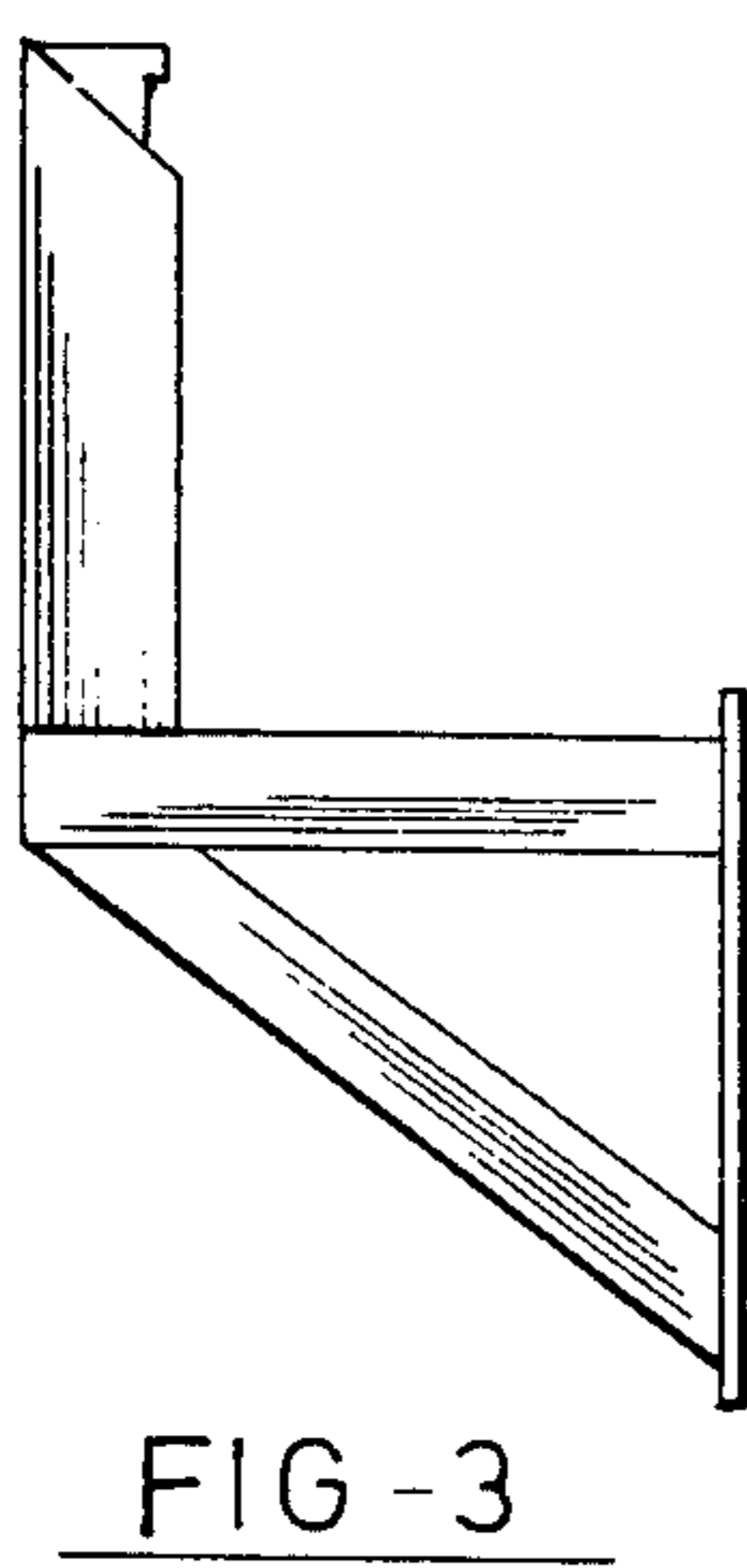
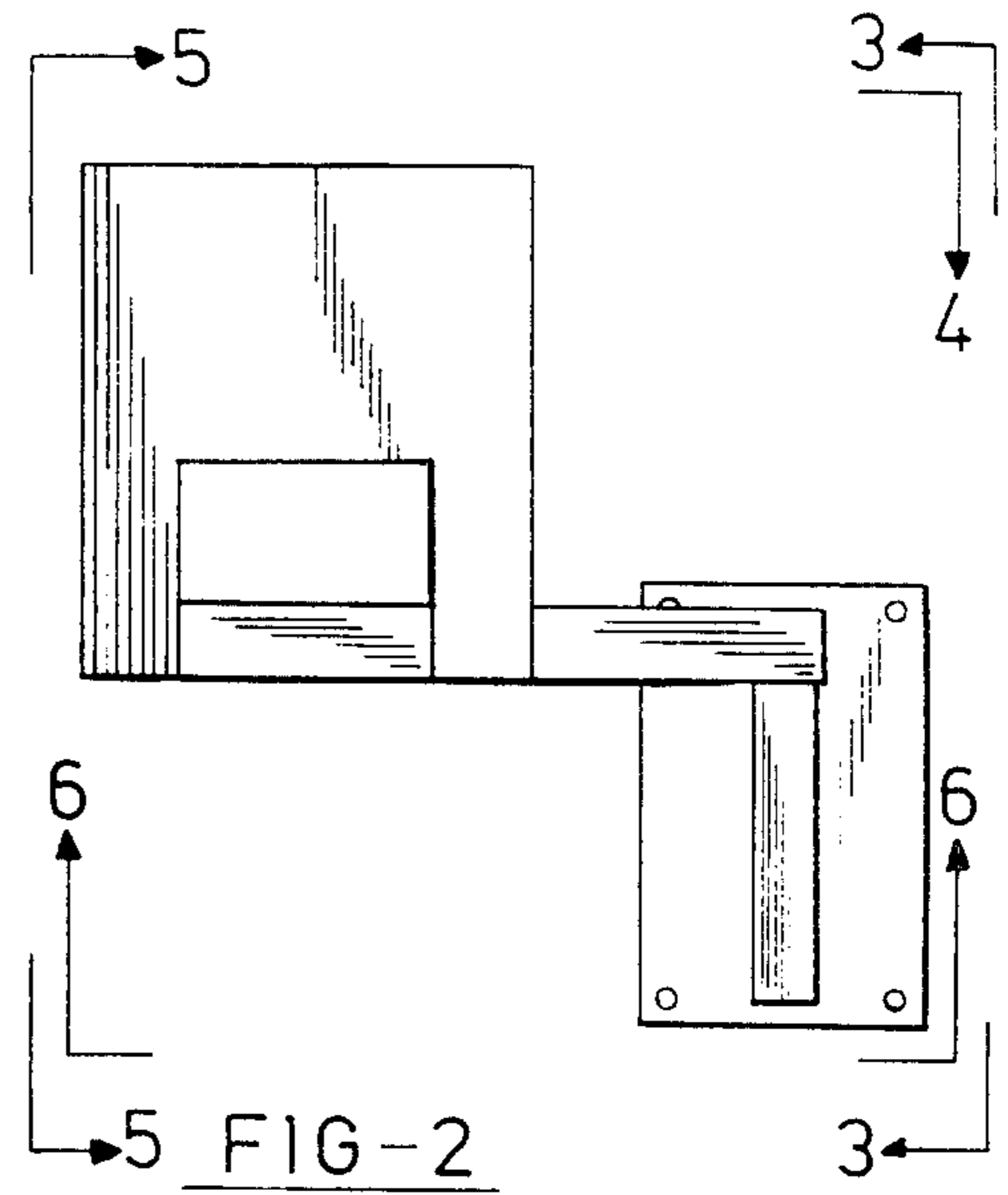
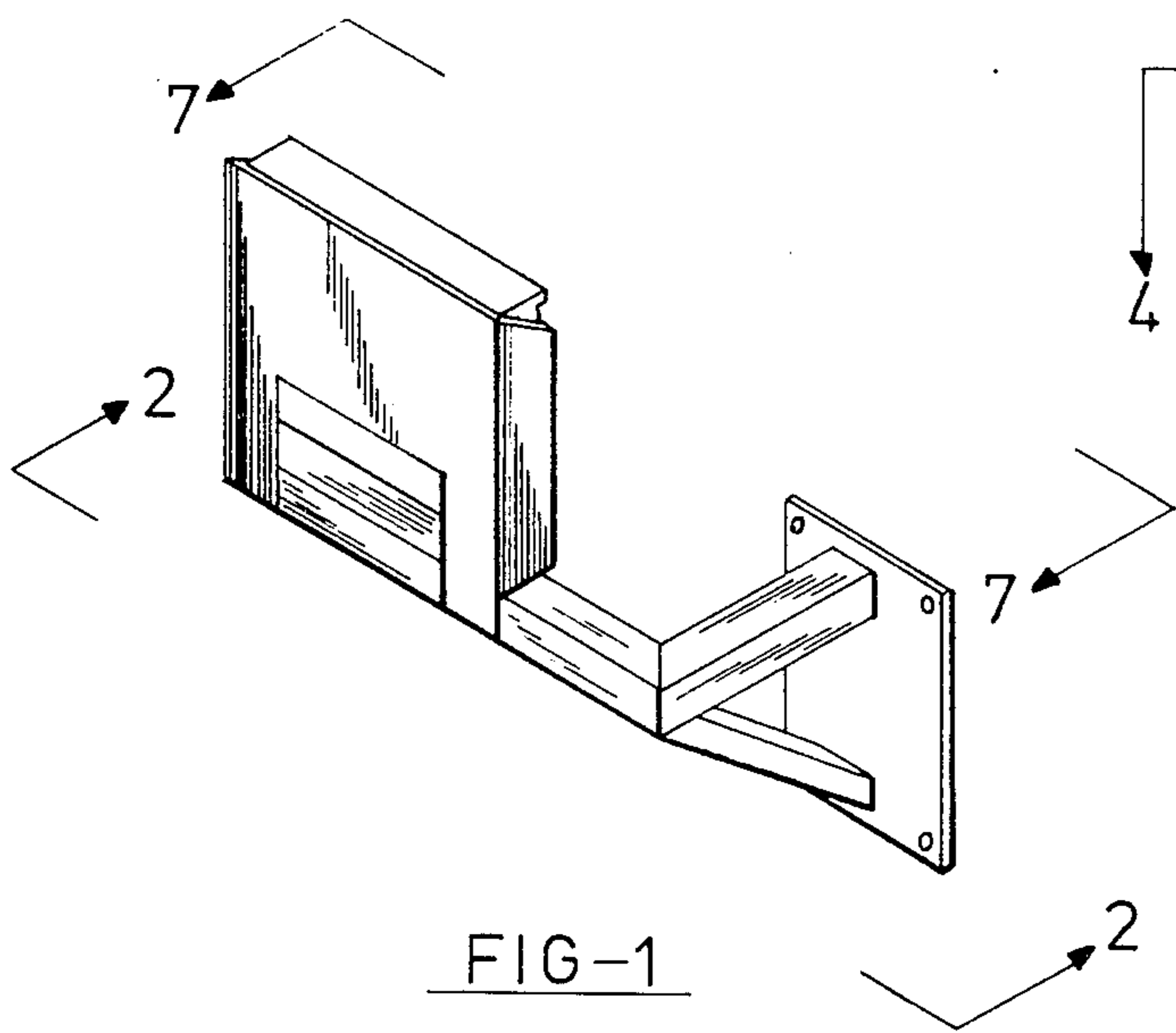

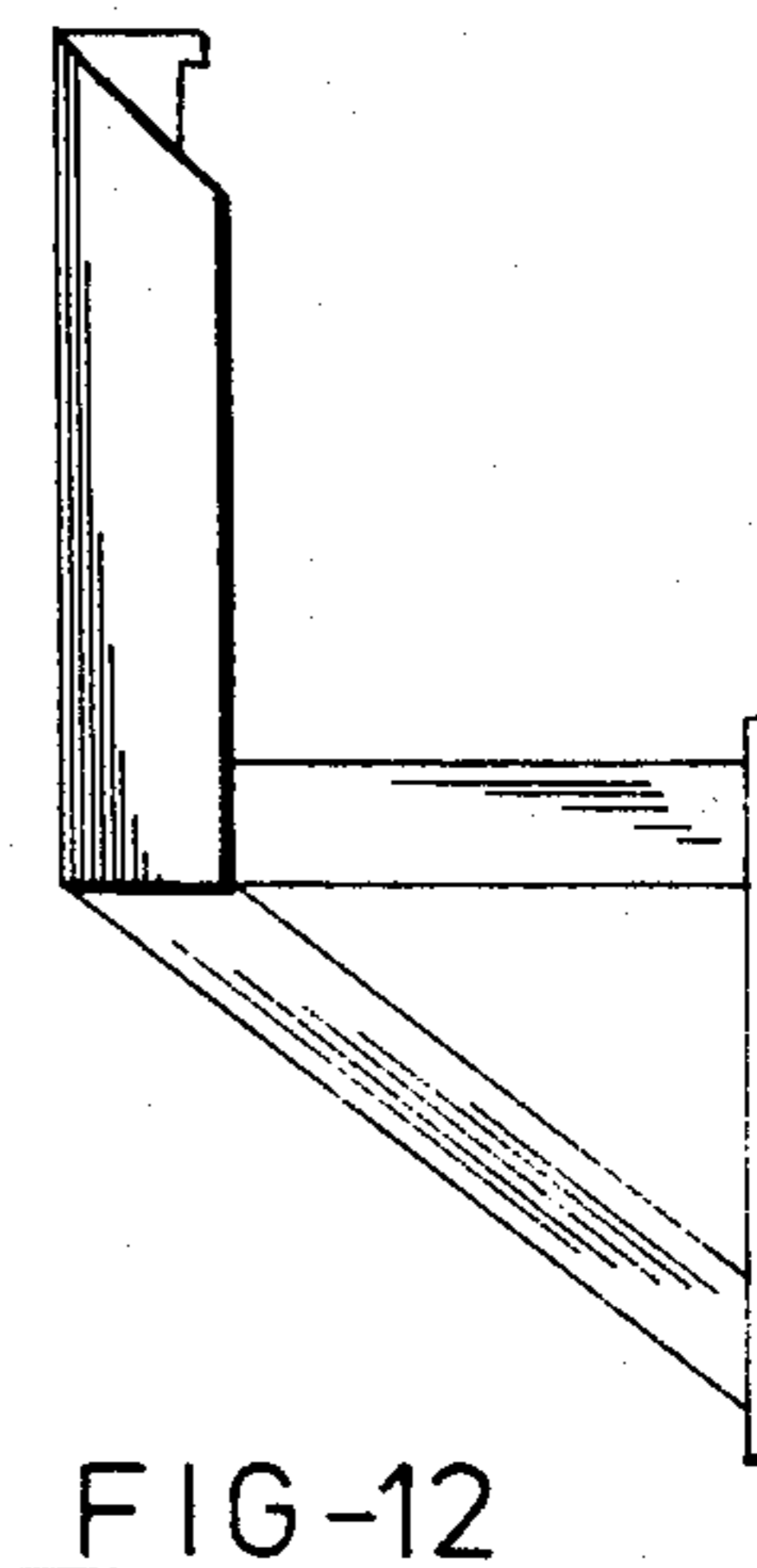
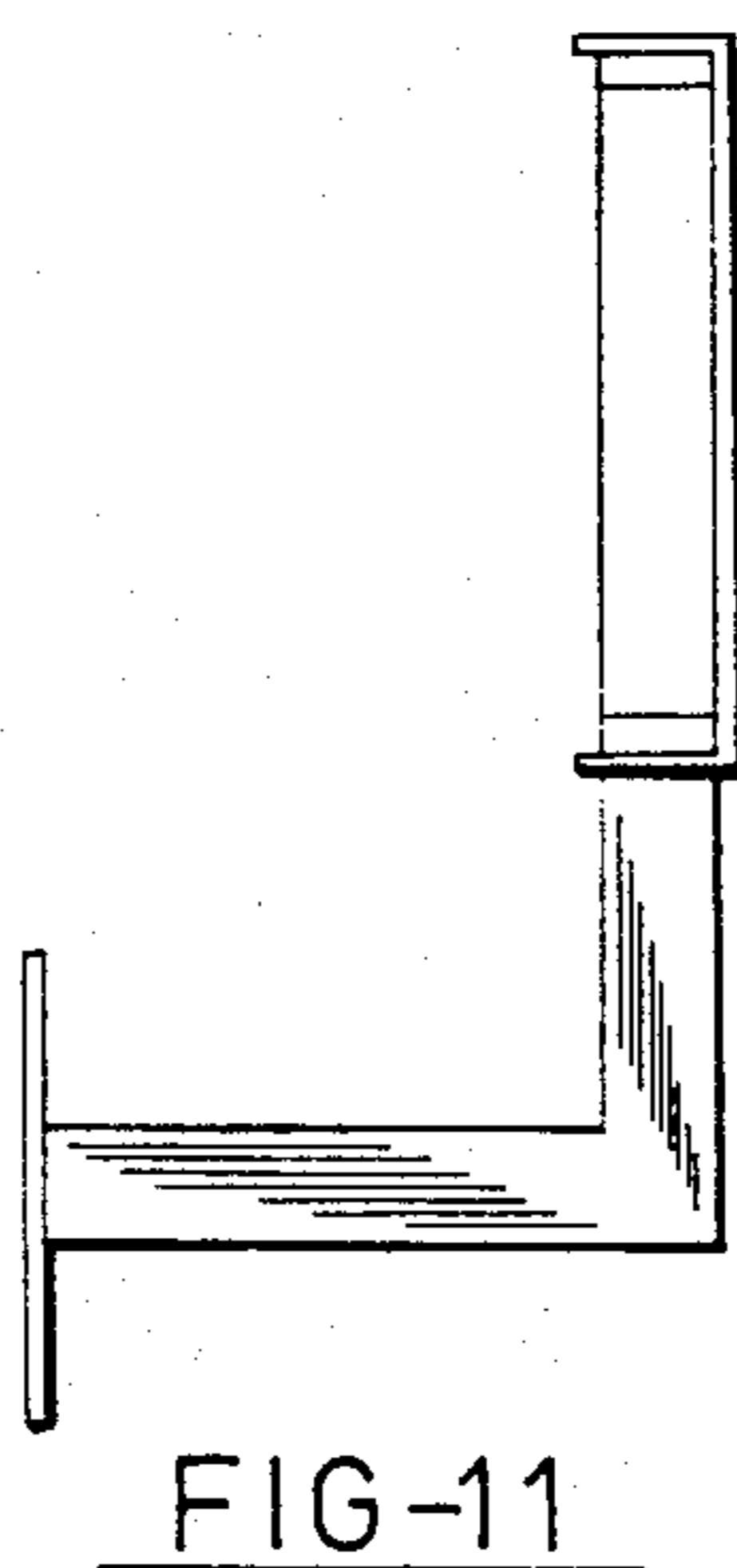
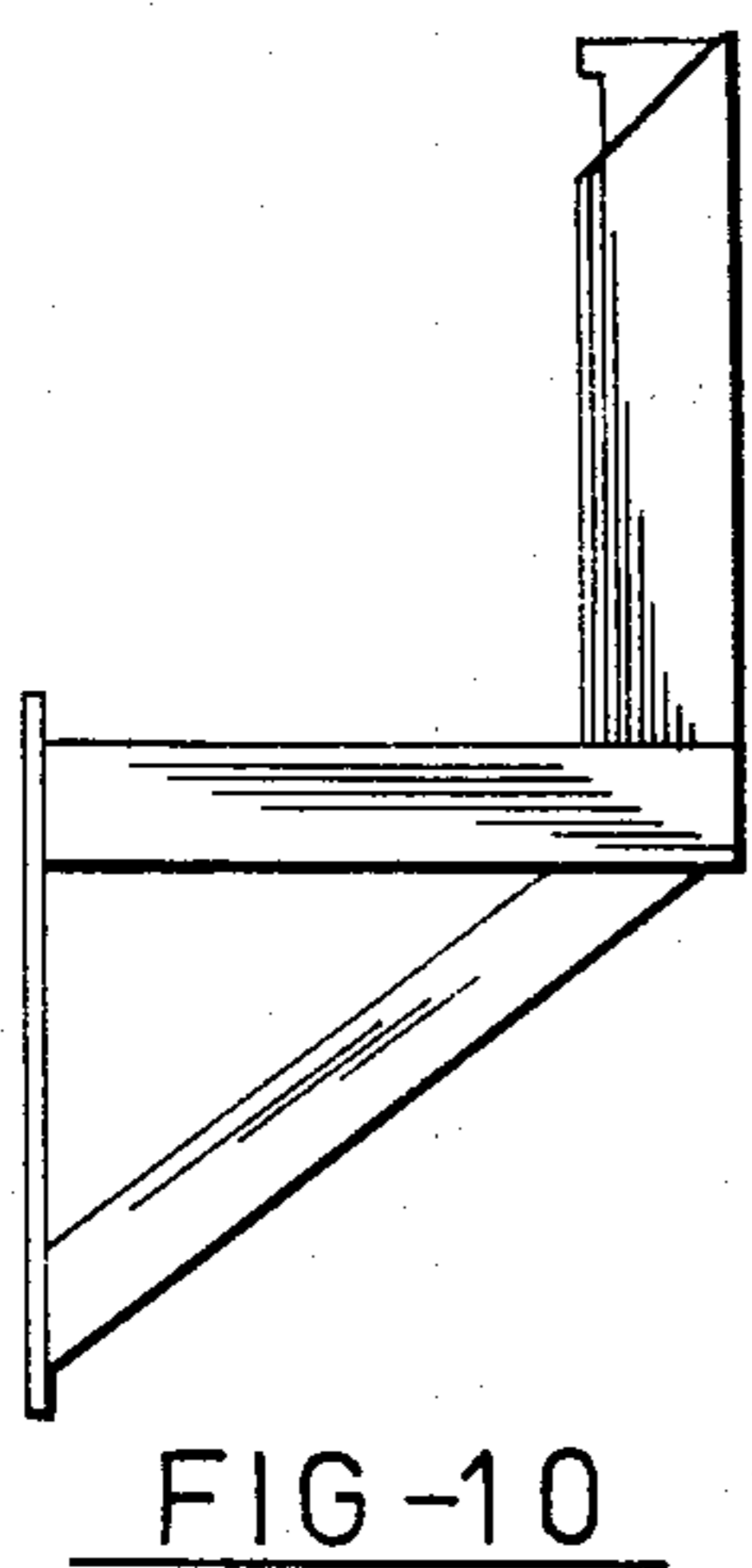
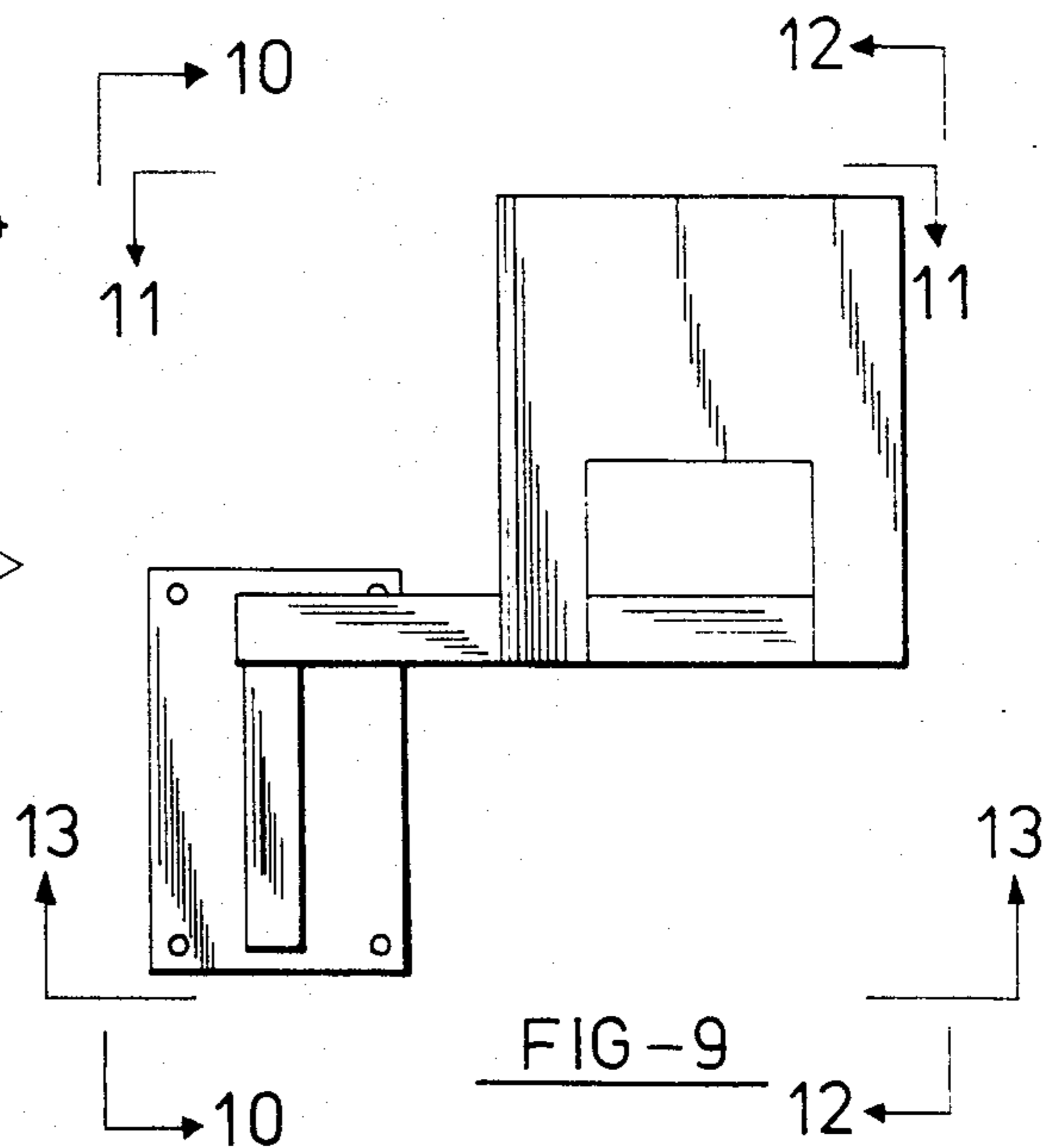
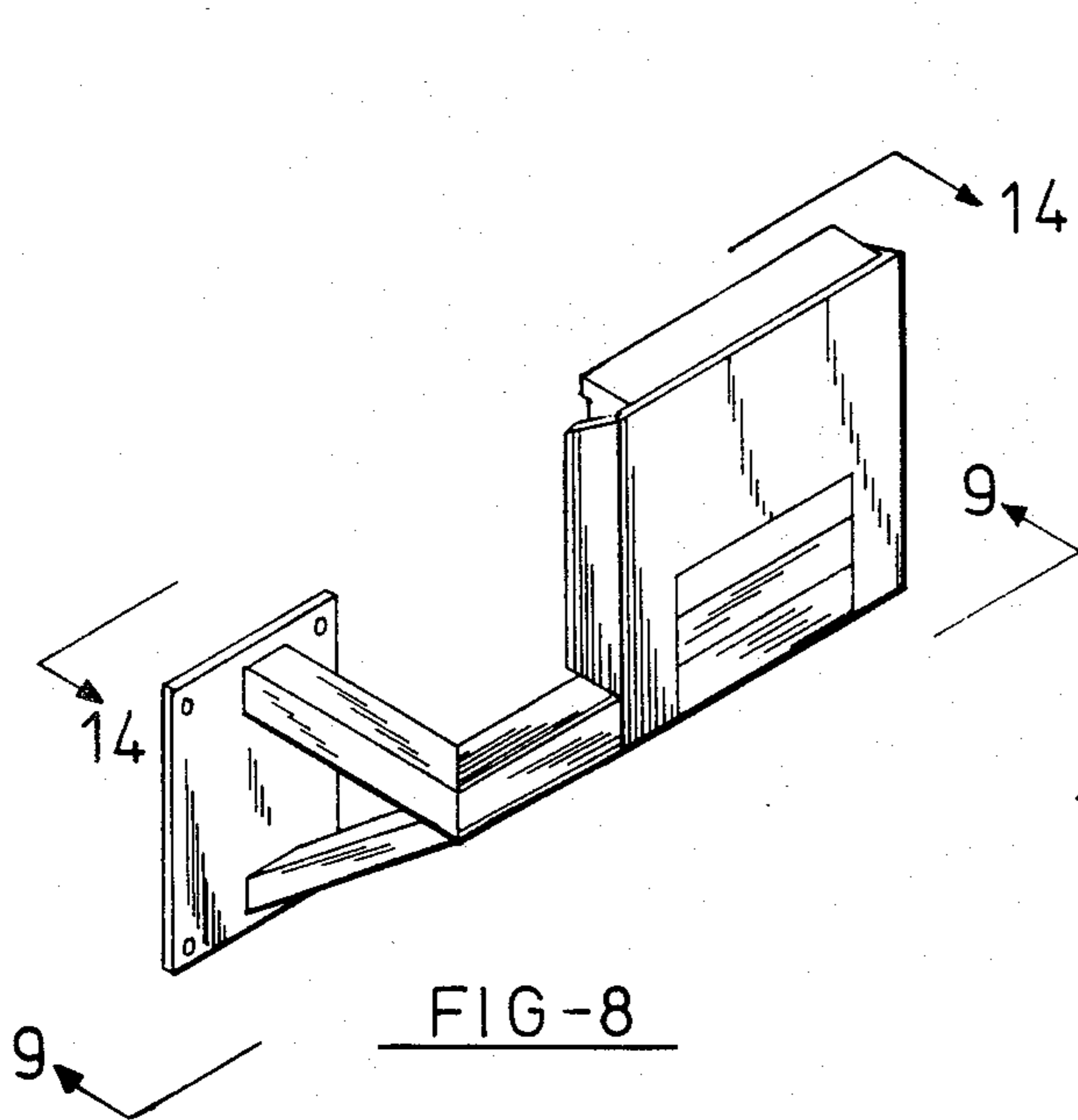

FIG-10

FIG-11

FIG-12

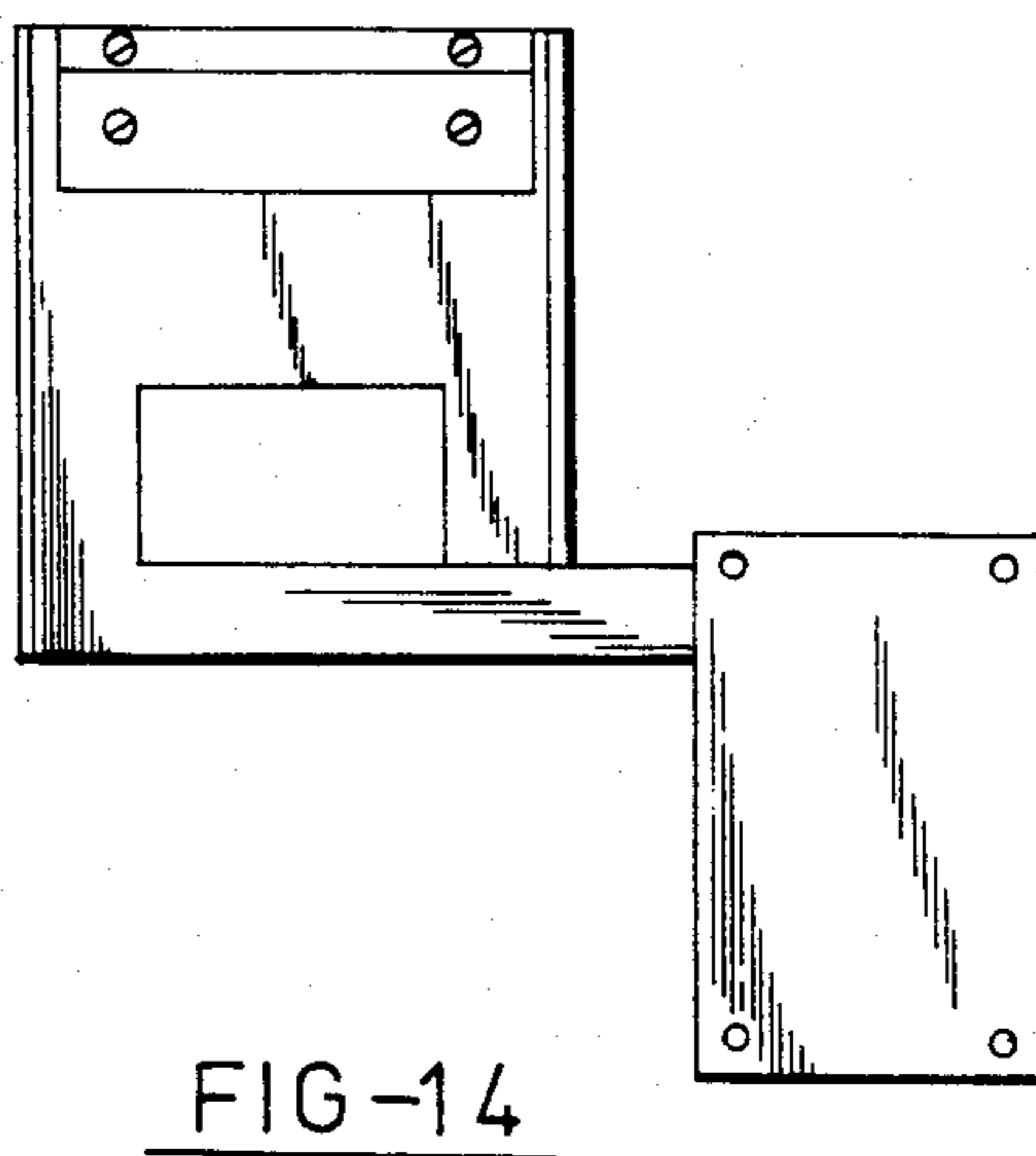
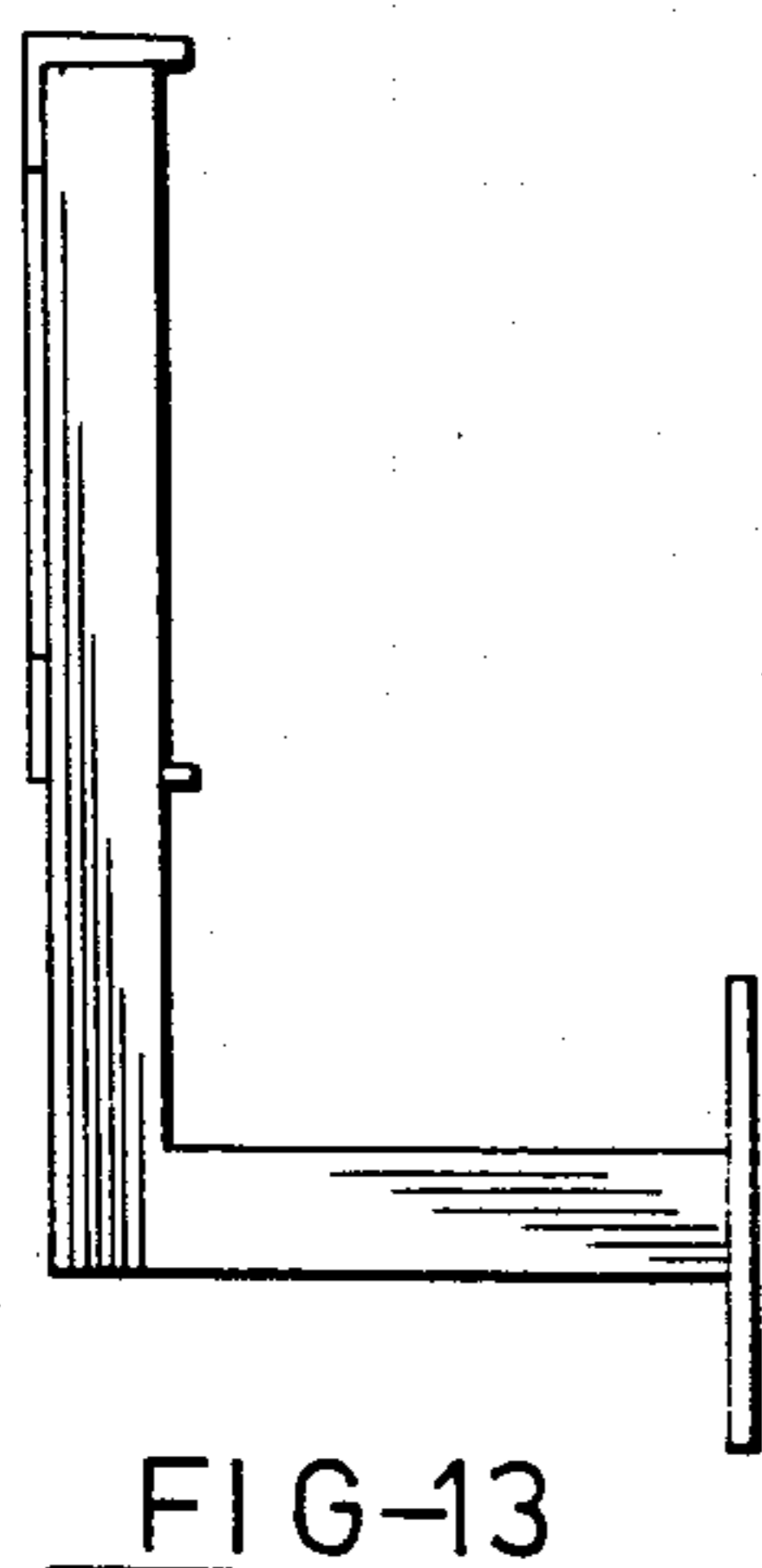

FIG-13

FIG-14