

[54] TOY TRAILER

[75] Inventor: Karl D. Lerch, East Aurora, N.Y.

[73] Assignee: The Quaker Oats Company, Chicago, Ill.

[**] Term: 14 Years

[21] Appl. No.: 459,885

[22] Filed: Jan. 21, 1983

[52] U.S. Cl. D21/134

[58] Field of Search D21/71, 76, 78, 80, D21/134, 136, 137, 140; D12/102, 105, 101; 446/174, 95, 460, 465, 469, 470

[56] References Cited

U.S. PATENT DOCUMENTS

D. 102,182 12/1936 Falk D12/102

3,935,954 2/1976 Woods et al. D12/101

FOREIGN PATENT DOCUMENTS

343807 2/1960 Switzerland D12/105

Primary Examiner—Charles A. Rademaker
Attorney, Agent, or Firm—Cumpston & Shaw

[57] CLAIM

The ornamental design for a toy trailer, substantially as shown and described.

DESCRIPTION

FIG. 1 is a right-side elevational view of a toy trailer showing our new design; FIG. 2 is a top plan view thereof; FIG. 3 is a left-side elevational view thereof; FIG. 4 is a bottom plan view thereof; FIG. 5 is a front elevational view thereof; and FIG. 6 is a rear elevational view thereof.

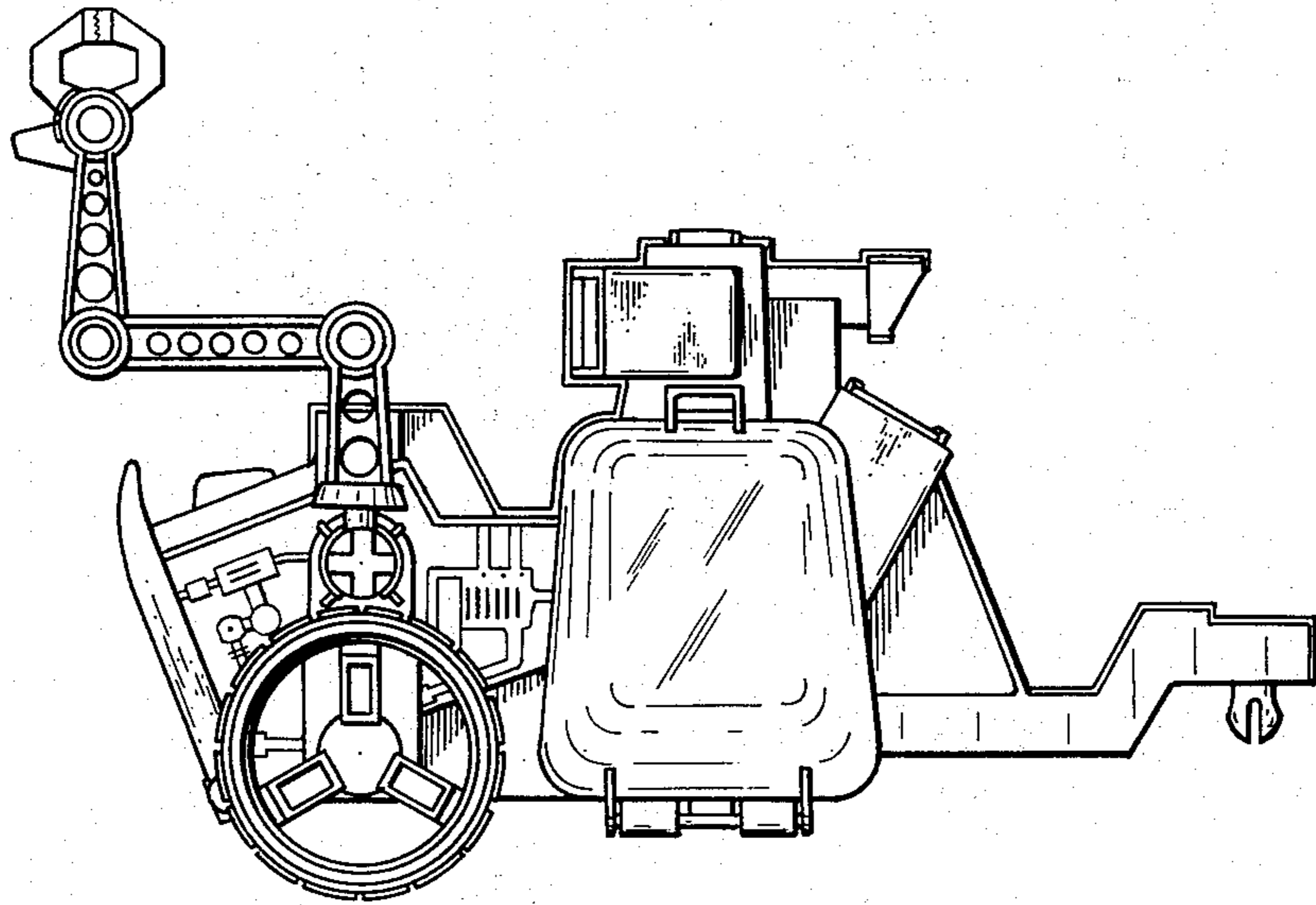

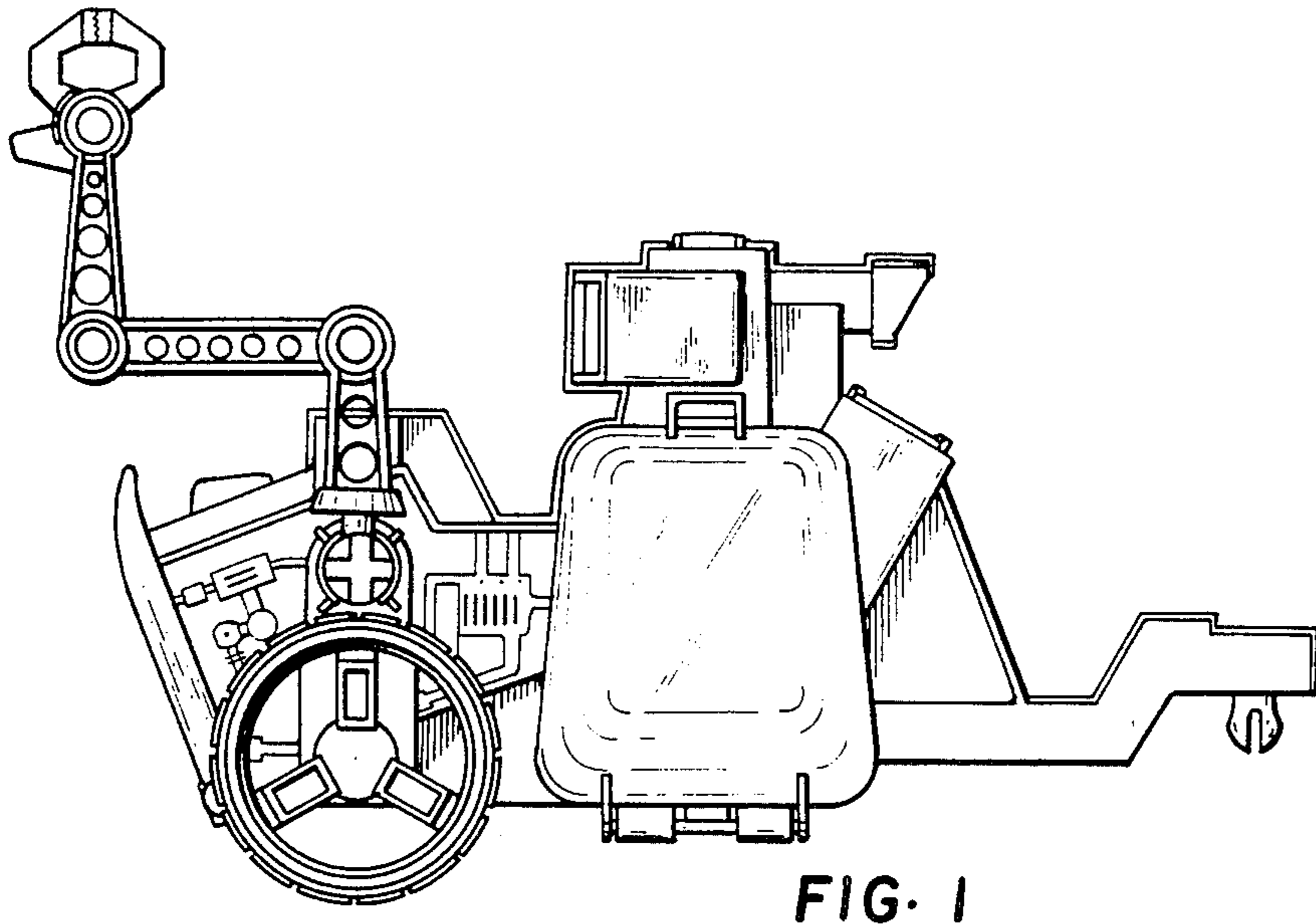

FIG. 1

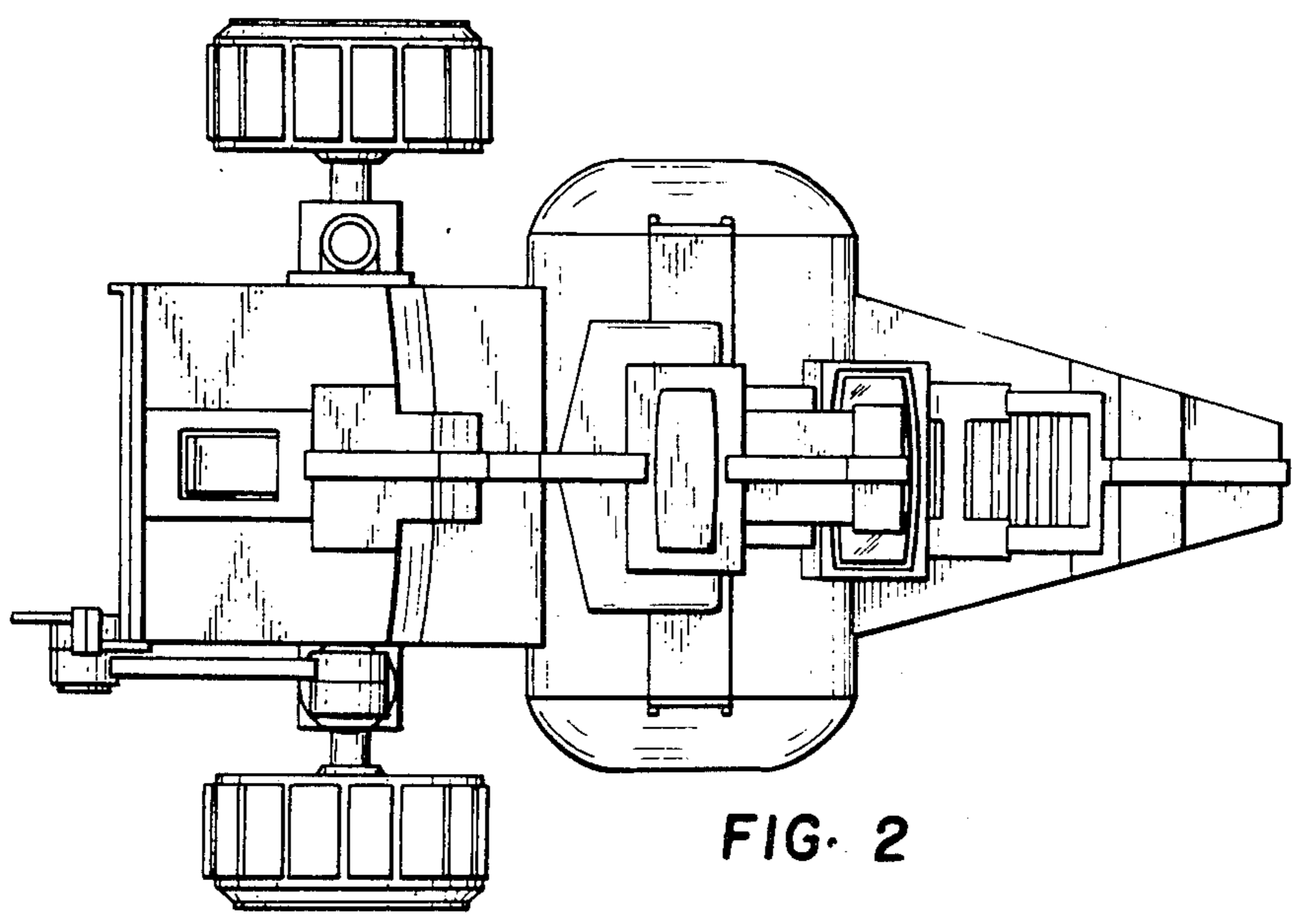

FIG. 2

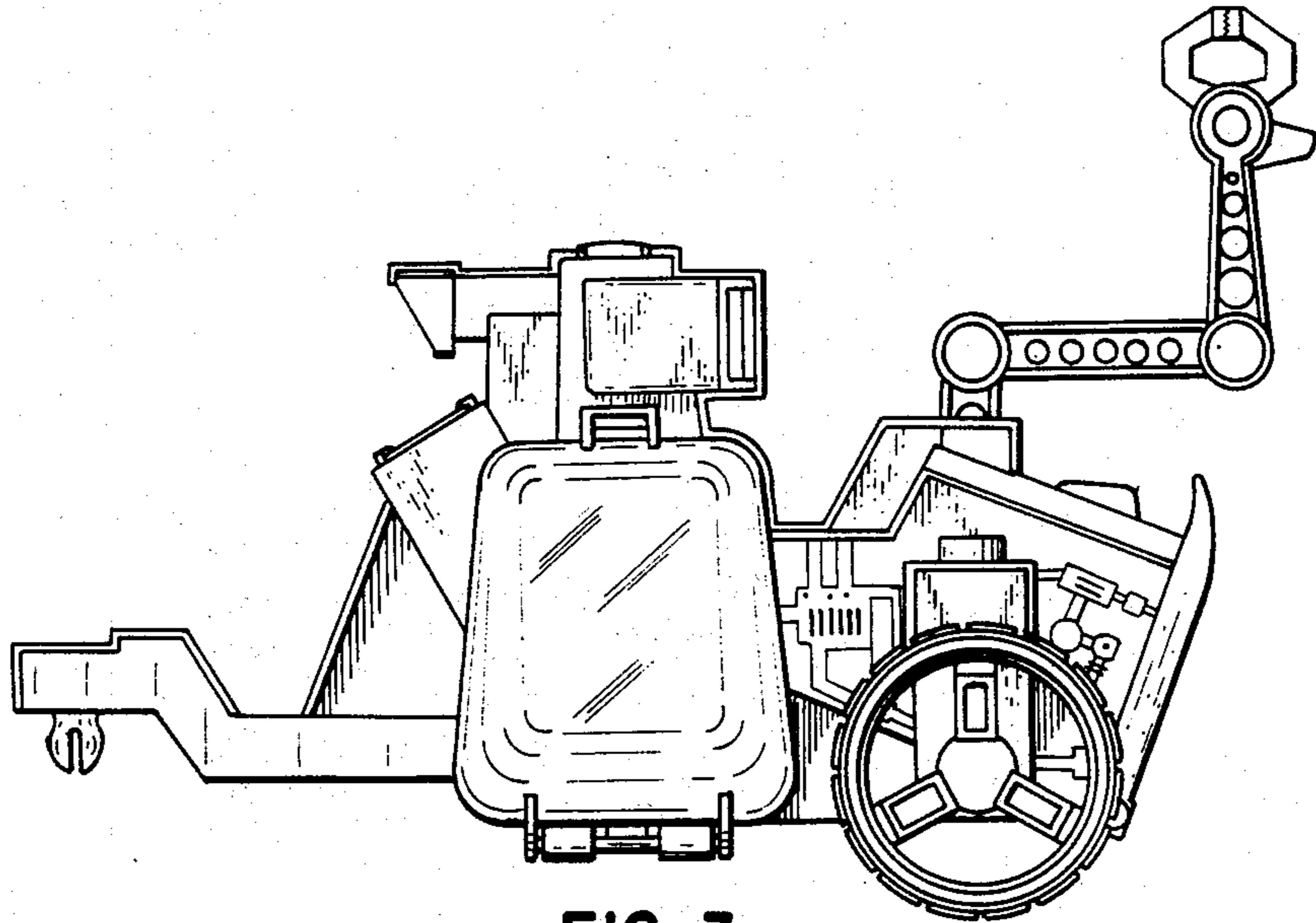

FIG. 3

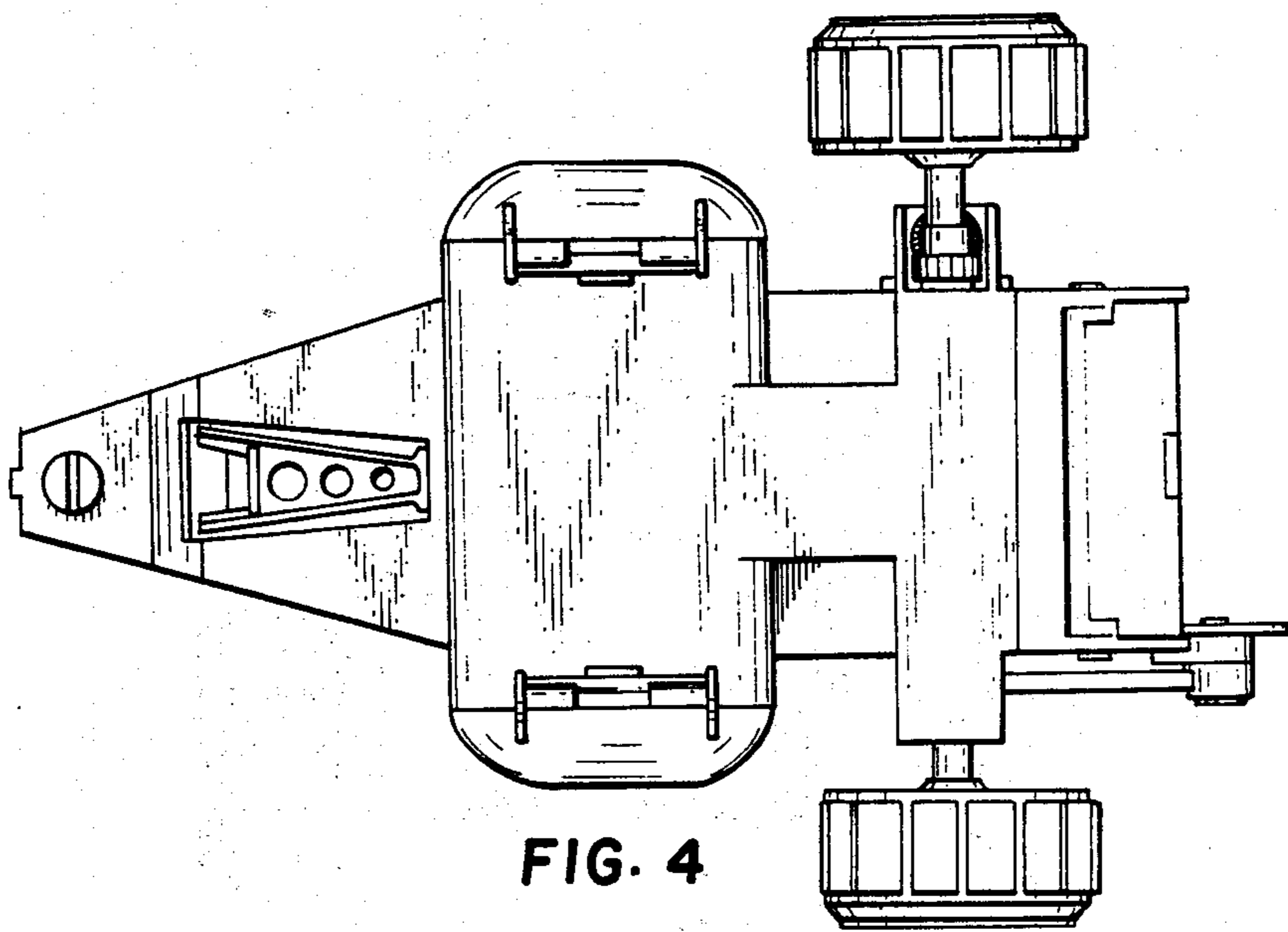

FIG. 4

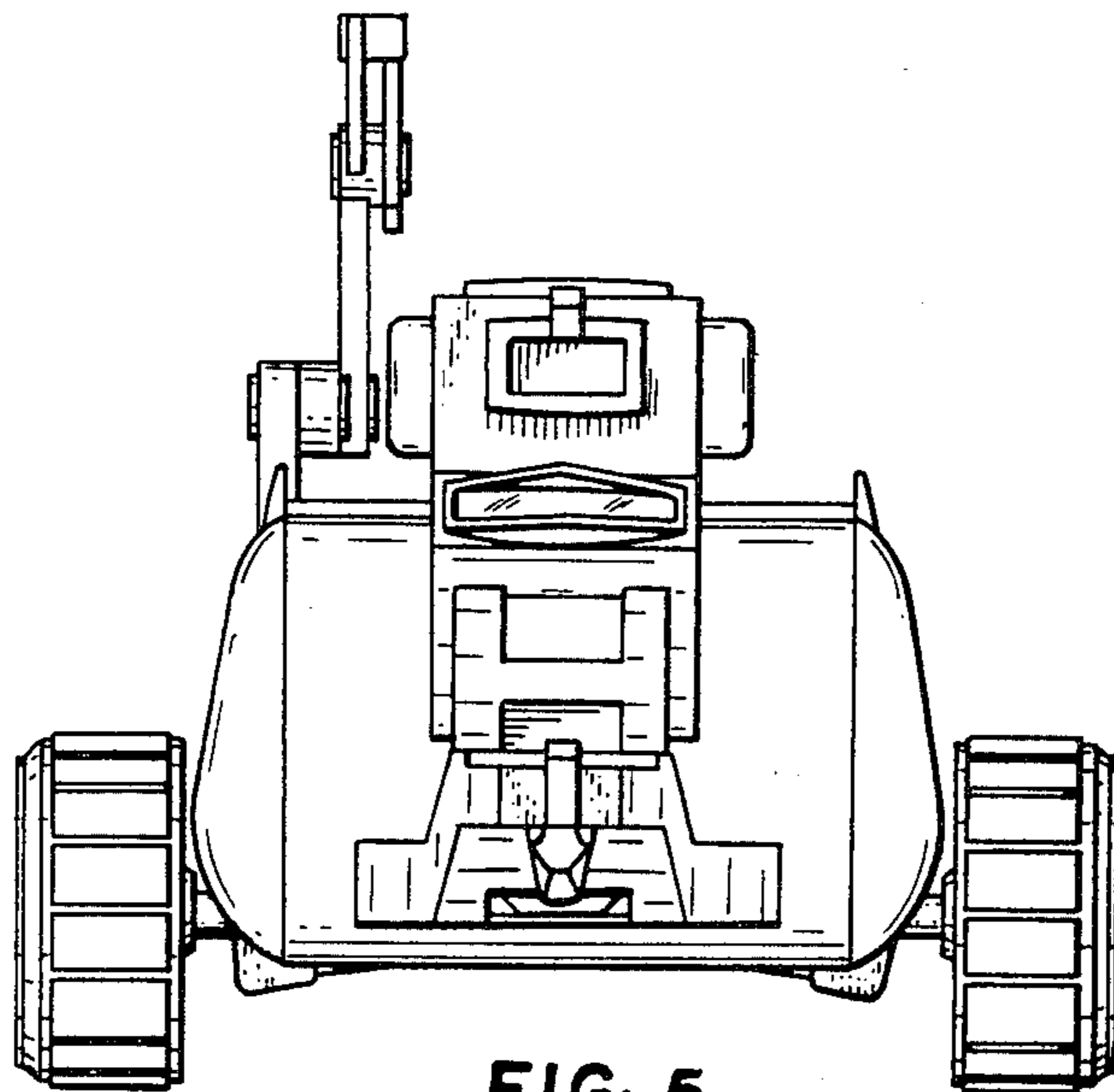

FIG. 5

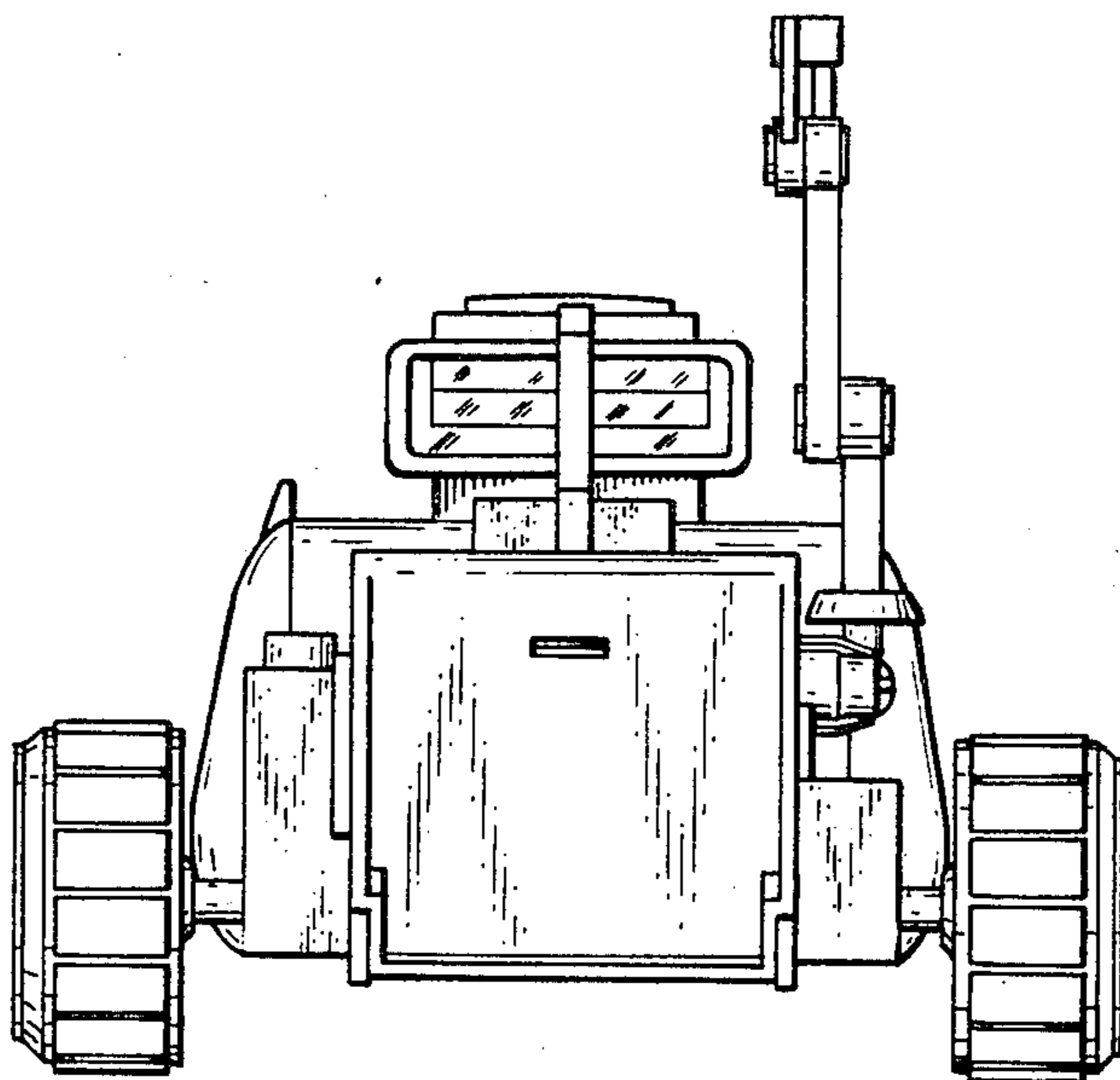

FIG. 6