

[54] PARKING BARRIER

[76] Inventor: Terry L. Souza, 1283 Terryglen La., San Dimas, Calif. 92773

[**] Term: 14 Years

[21] Appl. No.: 441,279

[22] Filed: Nov. 12, 1982

[52] U.S. Cl. D10/109

[58] Field of Search D10/109-113, D10/121; 116/63 R, 63 P, 63 T, 63 C; 350/97, 99, 100, 103; 40/606-607, 612; 404/6, 9, 10; 256/1, 13.1, DIG. 5; 52/116; 248/158, 291

[56] References Cited

U.S. PATENT DOCUMENTS

D. 253,637	12/1979	Wellbourne	D10/109
3,235,214	2/1966	Sprung	40/606
3,917,231	11/1975	Fink	404/6
4,137,662	2/1979	Baumer	40/612

Primary Examiner—B. J. Bullock
Assistant Examiner—Suzanne N. Gitlin
Attorney, Agent, or Firm—Michael W. York

[57] CLAIM

The ornamental design for a parking barrier, substantially as shown and described.

DESCRIPTION

FIG. 1 is a front elevational view of a parking barrier showing my new design, it being shown in operational condition;
FIG. 2 is a side elevational view taken from the right of FIG. 1, the opposite side being a mirror image thereof;
FIG. 3 is a rear elevational view thereof;
FIG. 4 is a top plan view taken from line 4—4 of FIG. 1;
FIG. 5 is a bottom plan view taken from line 5—5 of FIG. 1;
FIG. 6 is a top plan view thereof, it being shown in stowable condition;
FIG. 7 is a side elevational view, the opposite side being a mirror image thereof;
FIG. 8 is a bottom plan view thereof;
FIG. 9 is an end elevational view taken from line 9—9 of FIG. 6;
FIG. 10 is an end elevational view taken from line 10—10 of FIG. 6; and
FIG. 11 is a front and one side perspective view thereof, it being shown in operational condition.

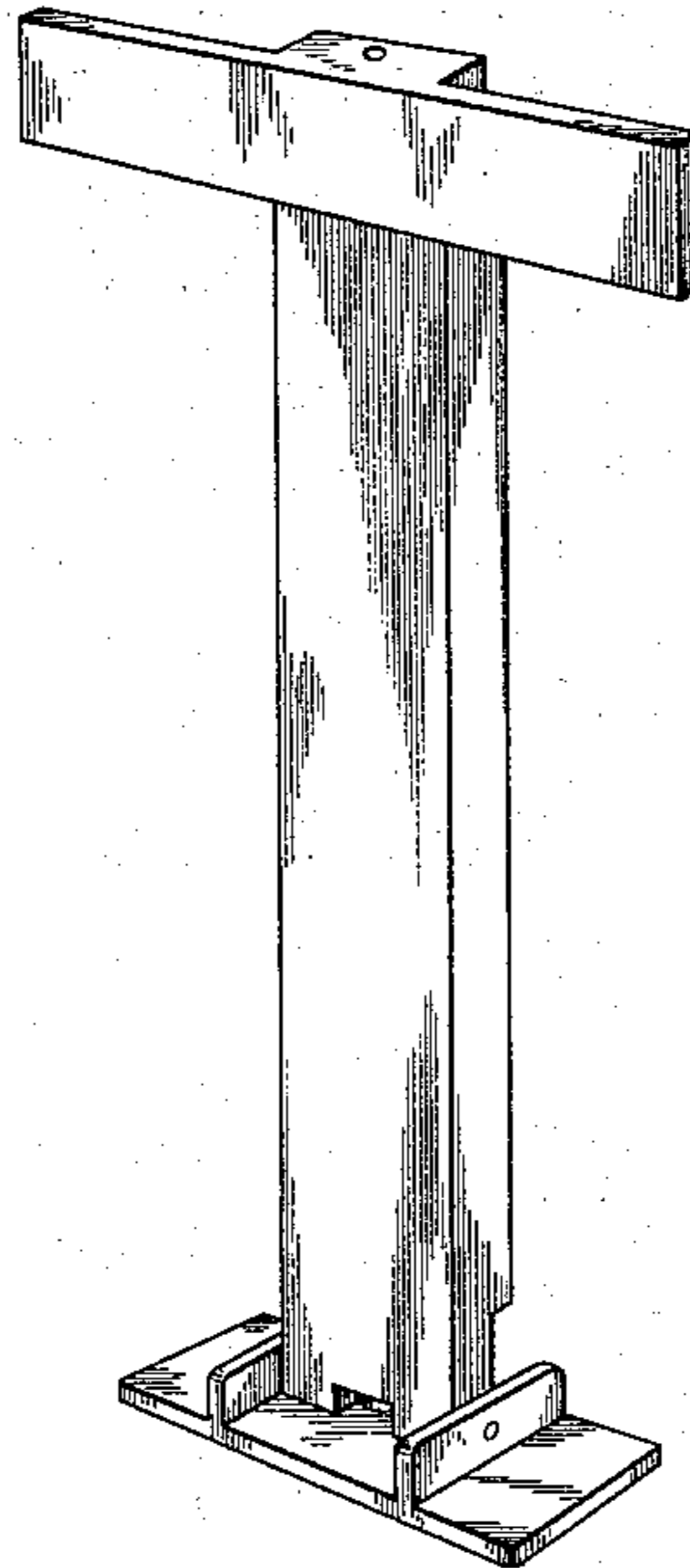

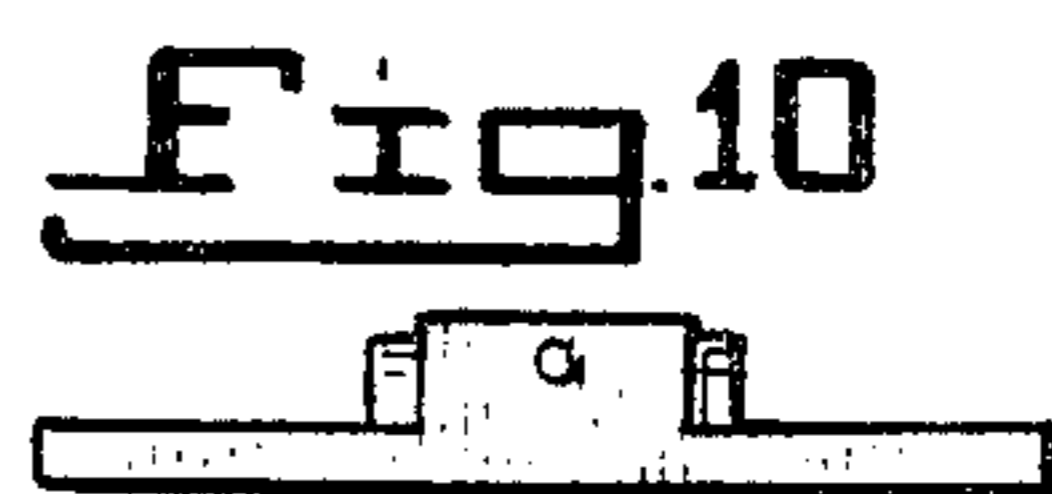
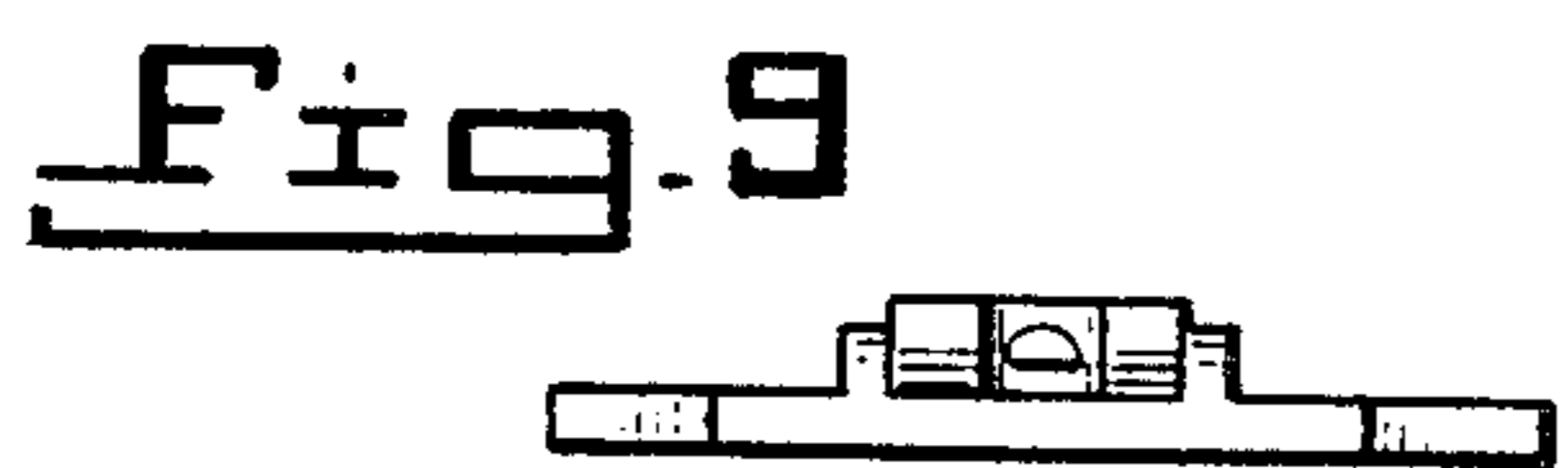
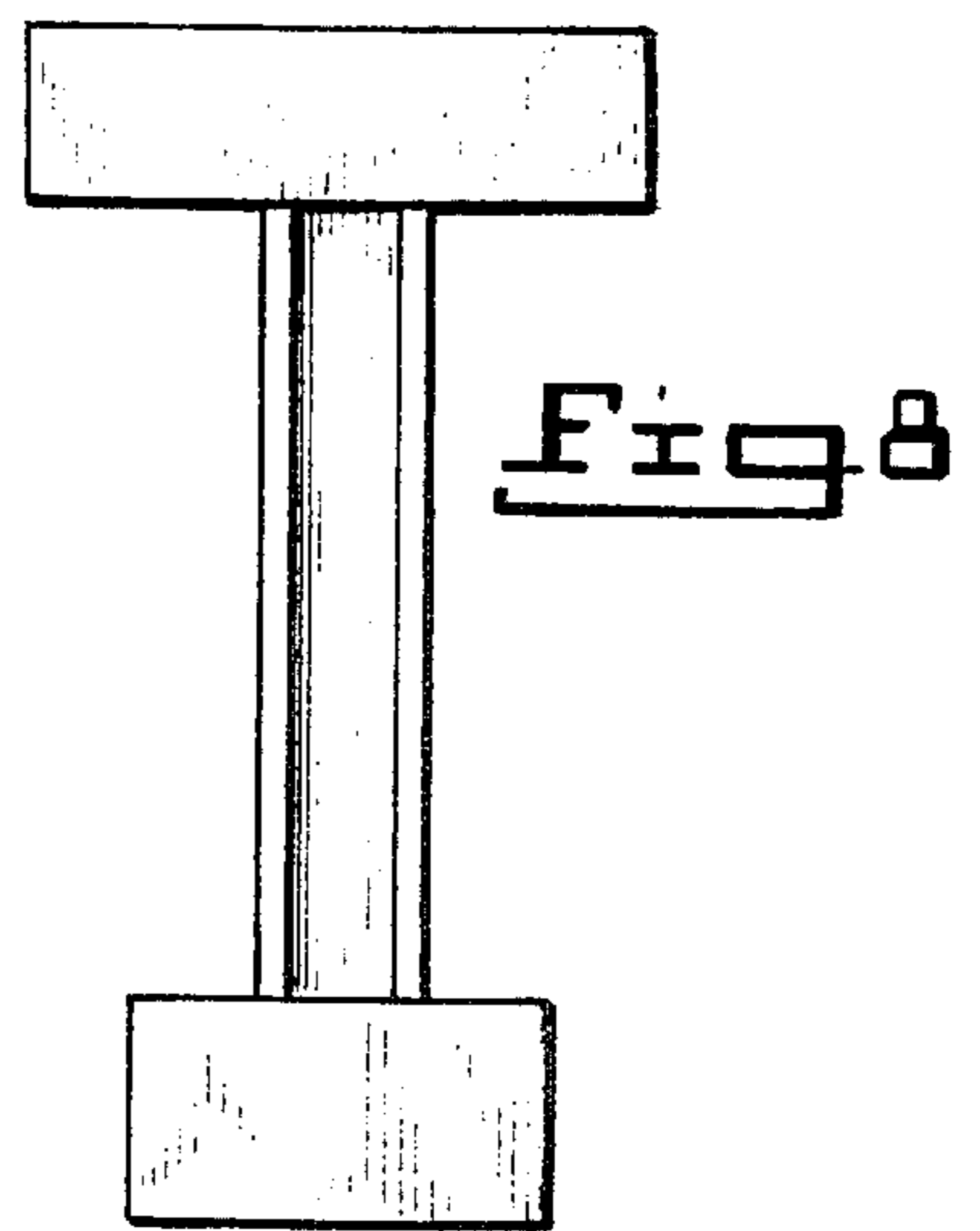
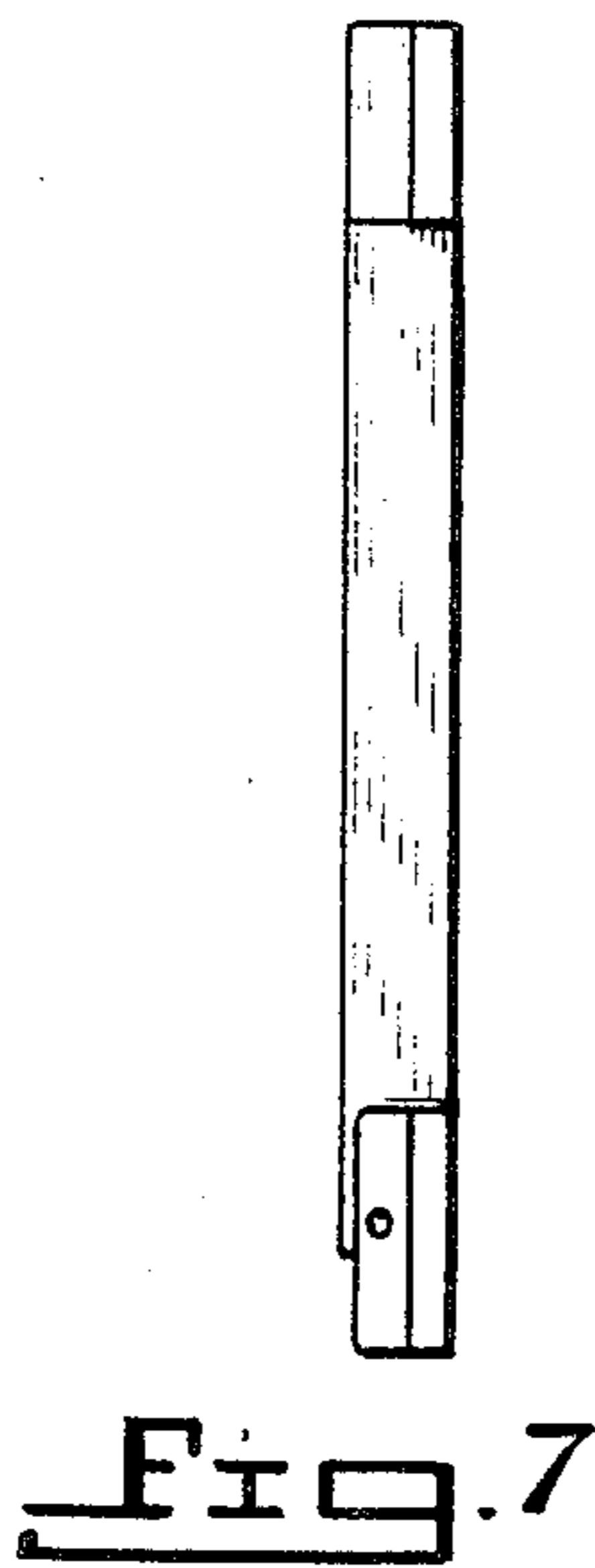
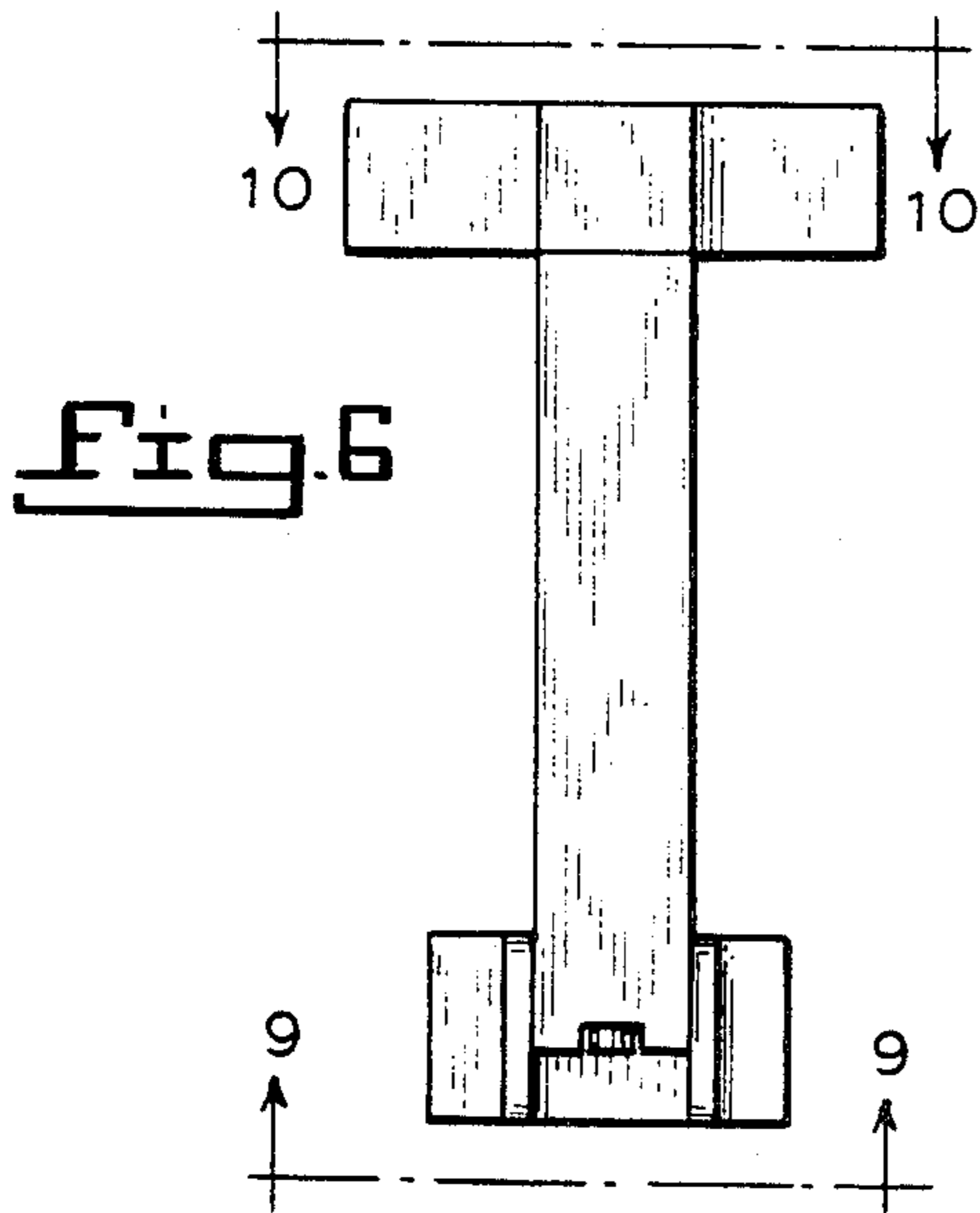
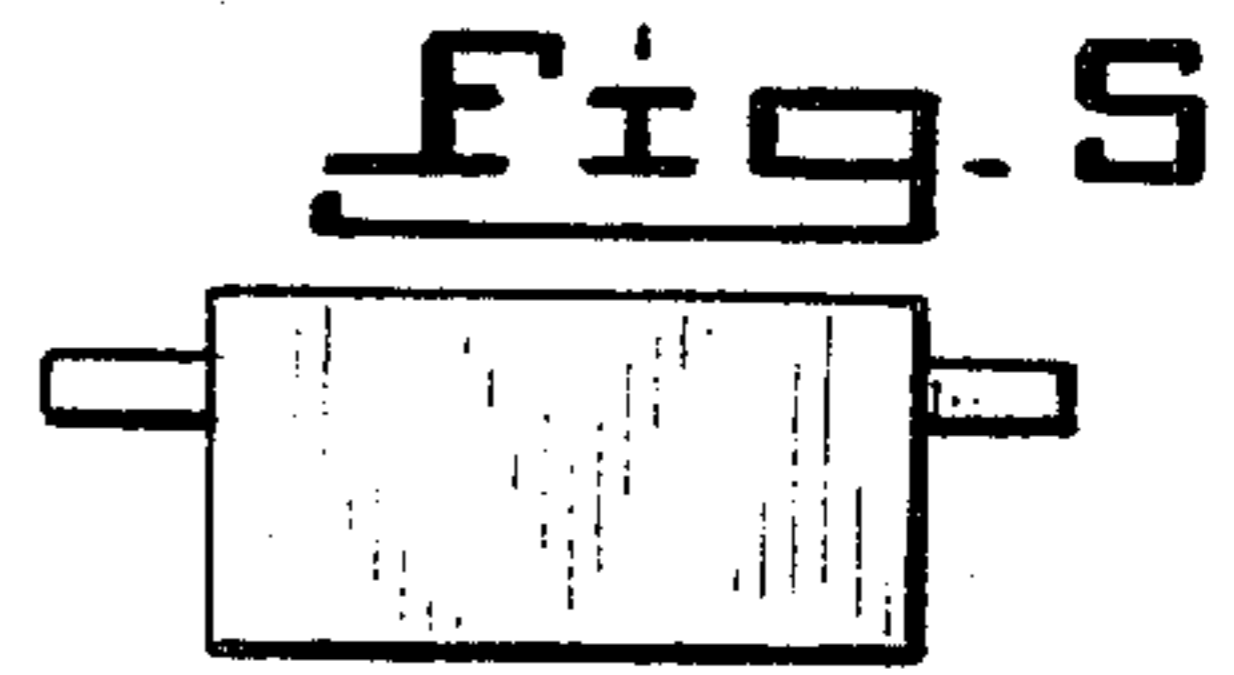
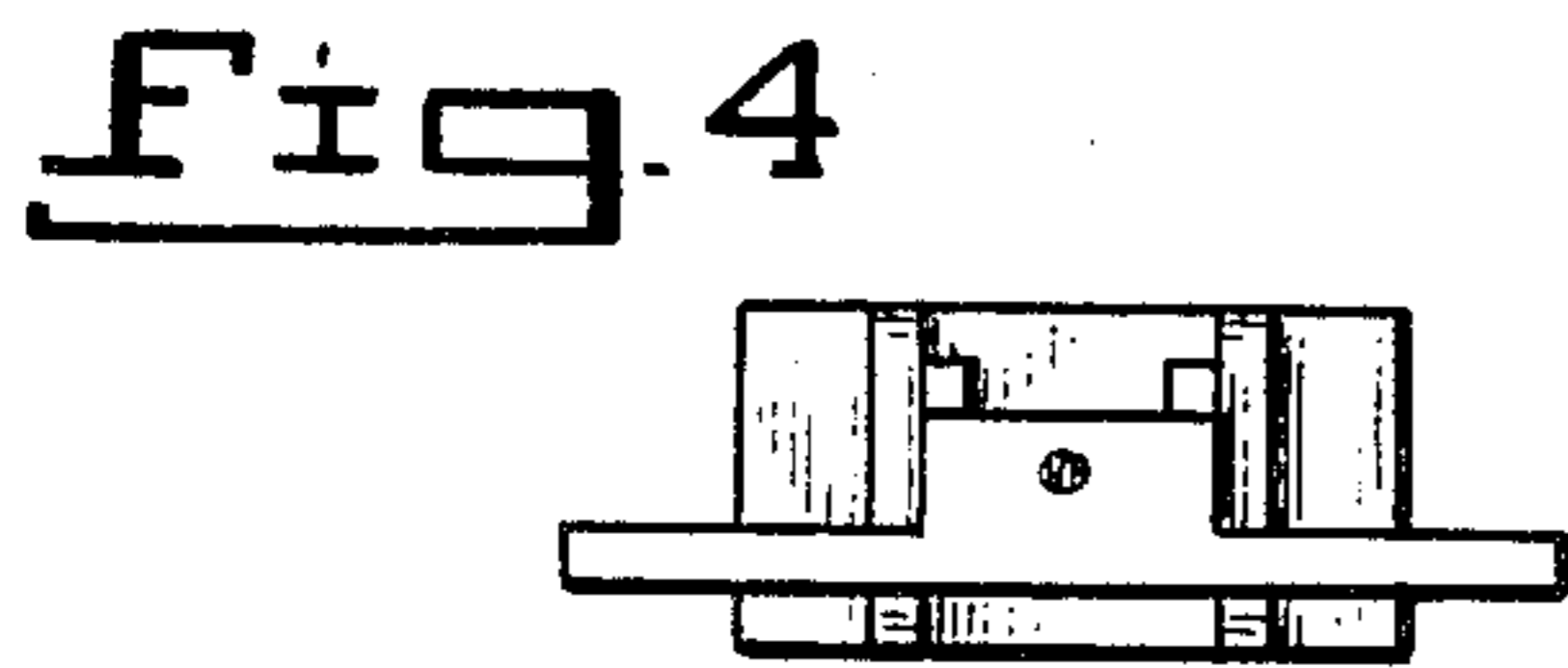
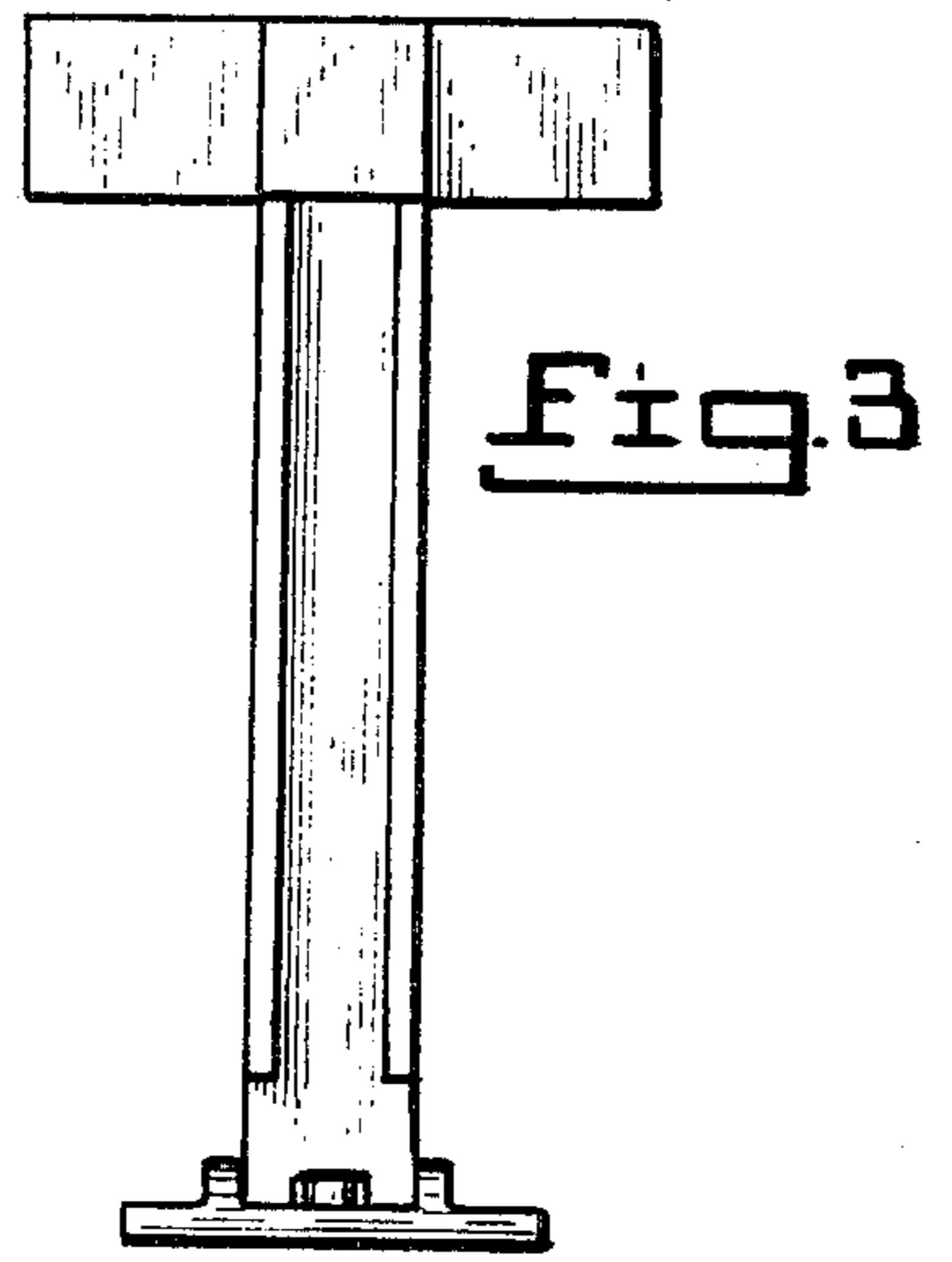
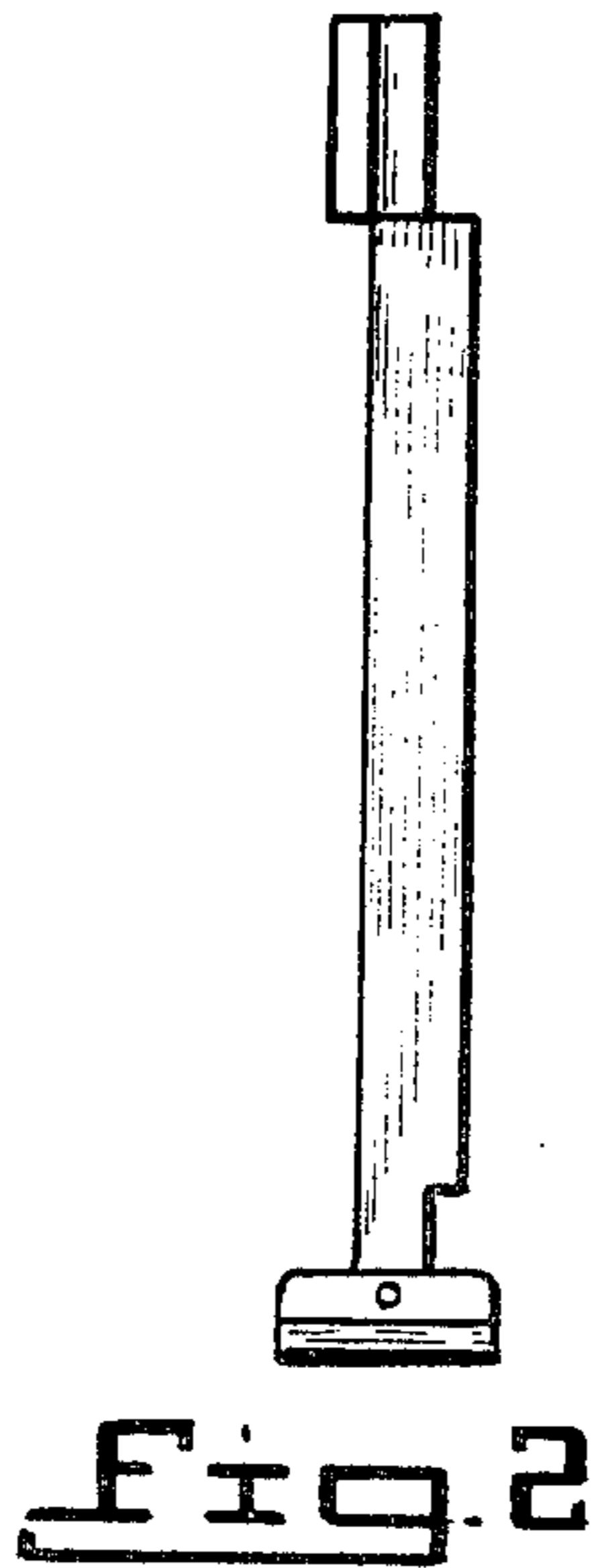
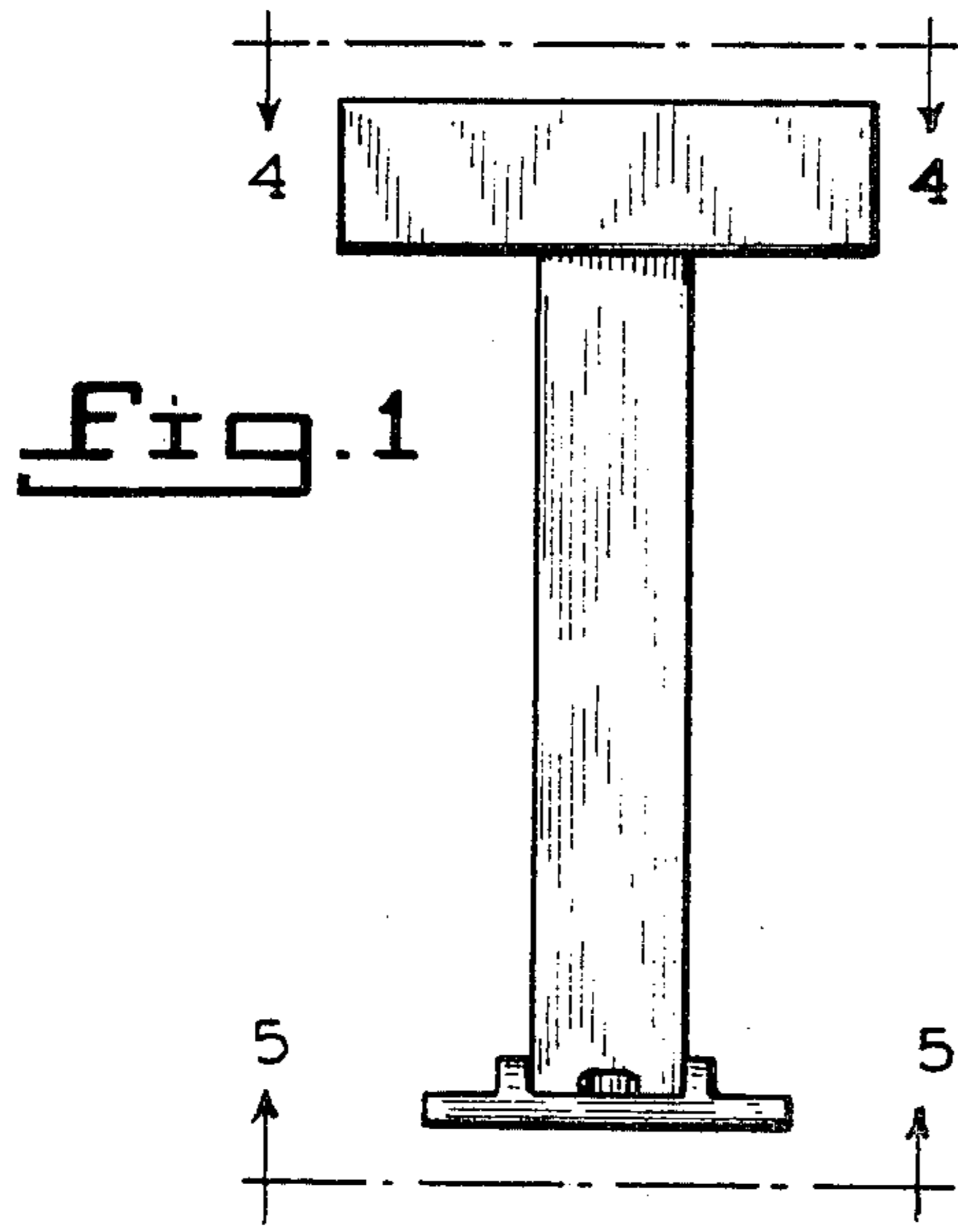

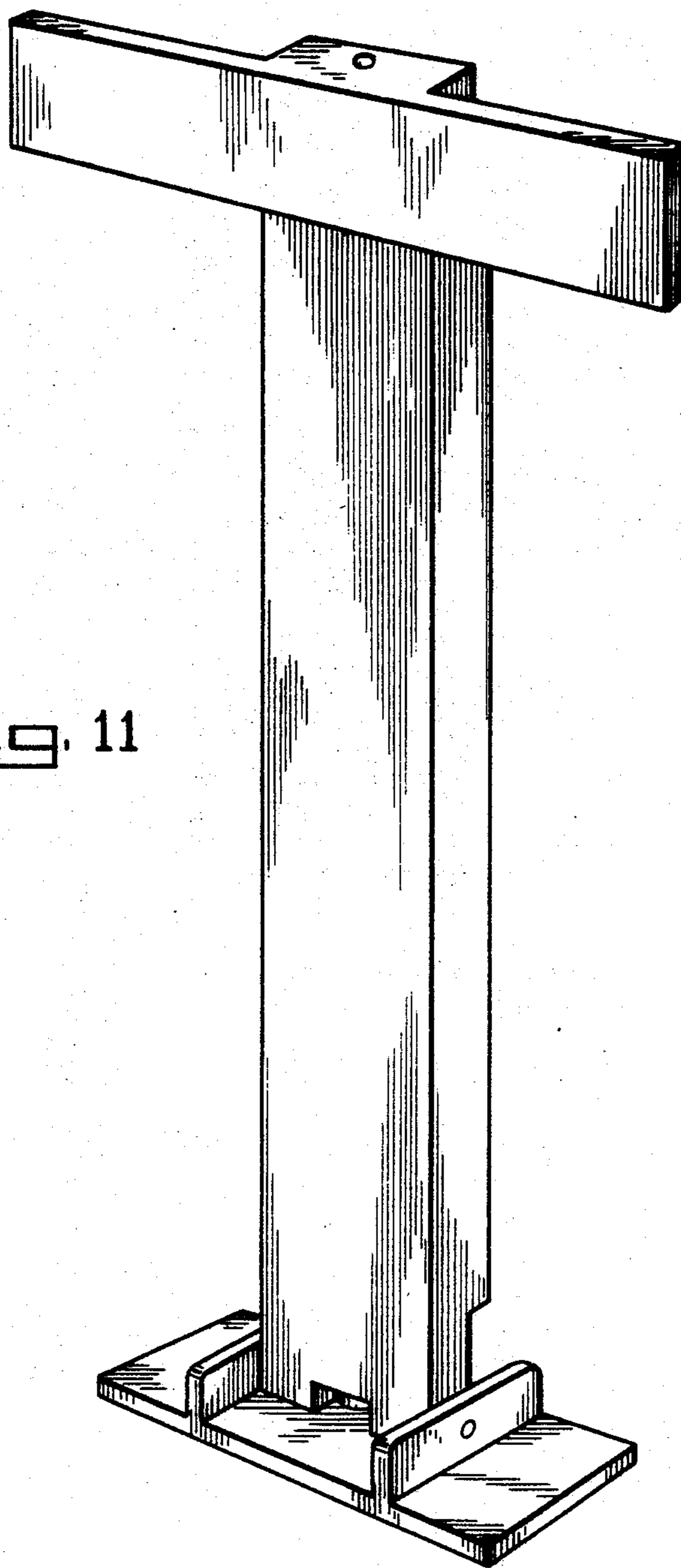

Fig. 11