

[54] A COMBINED STRADDLE SEAT AND ARM REST REST

D. 209,048 10/1967 Shafer et al. D6/17
D. 260,203 8/1981 Arnold D6/17

[76] Inventors: **Richard P. Agan**, 2812 47th St., Des Moines, Iowa 50310; **Anna L. Dunahoo**, 3914 E. 8th St., Des Moines, Iowa 50316

Primary Examiner—Bruce W. Dunkins
Attorney, Agent, or Firm—Zarley, McKee, Thomte, Voorhees & Sease

[**] Term: 14 Years

[57] CLAIM

The ornamental design for a combined straddle seat and arm rest, substantially as shown and described.

[21] Appl. No.: 436,609

DESCRIPTION

[22] Filed: Feb. 7, 1983

[52] U.S. Cl. D6/354

[58] Field of Search D6/1, 17, 26, 64

FIG. 1 is a frontal perspective view of a combined straddle seat and arm rest showing our new design; FIG. 2 is a top plan view thereof; FIG. 3 is a frontal elevational view thereof; FIG. 4 is an elevational view thereof taken from the right of FIG. 3, the opposite side being a mirror image thereof; and FIG. 5 is a rear elevational view thereof.

[56] References Cited

U.S. PATENT DOCUMENTS

D. 61,355 8/1922 Anderson D6/17
D. 111,058 8/1938 Anderson D6/17

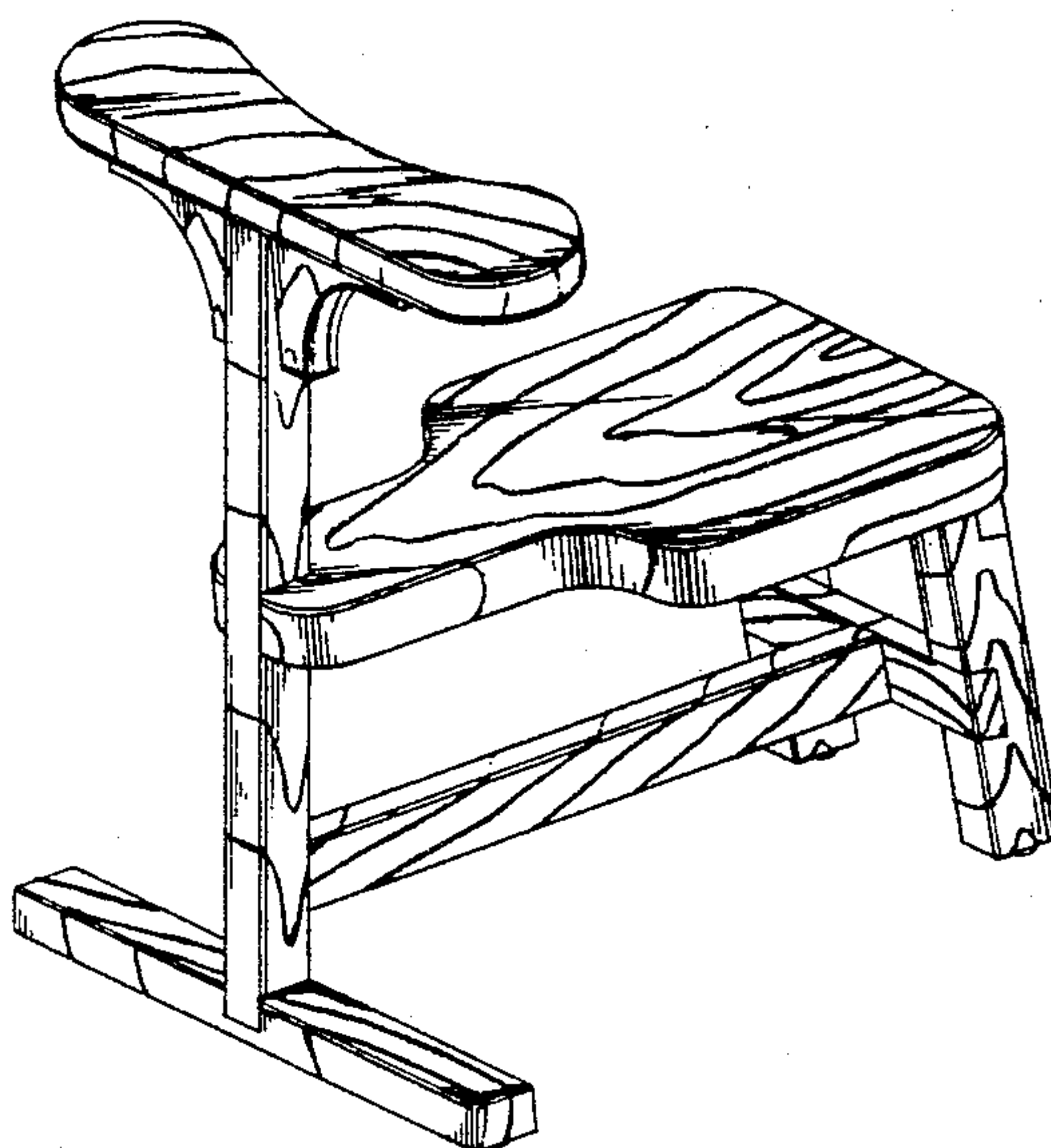

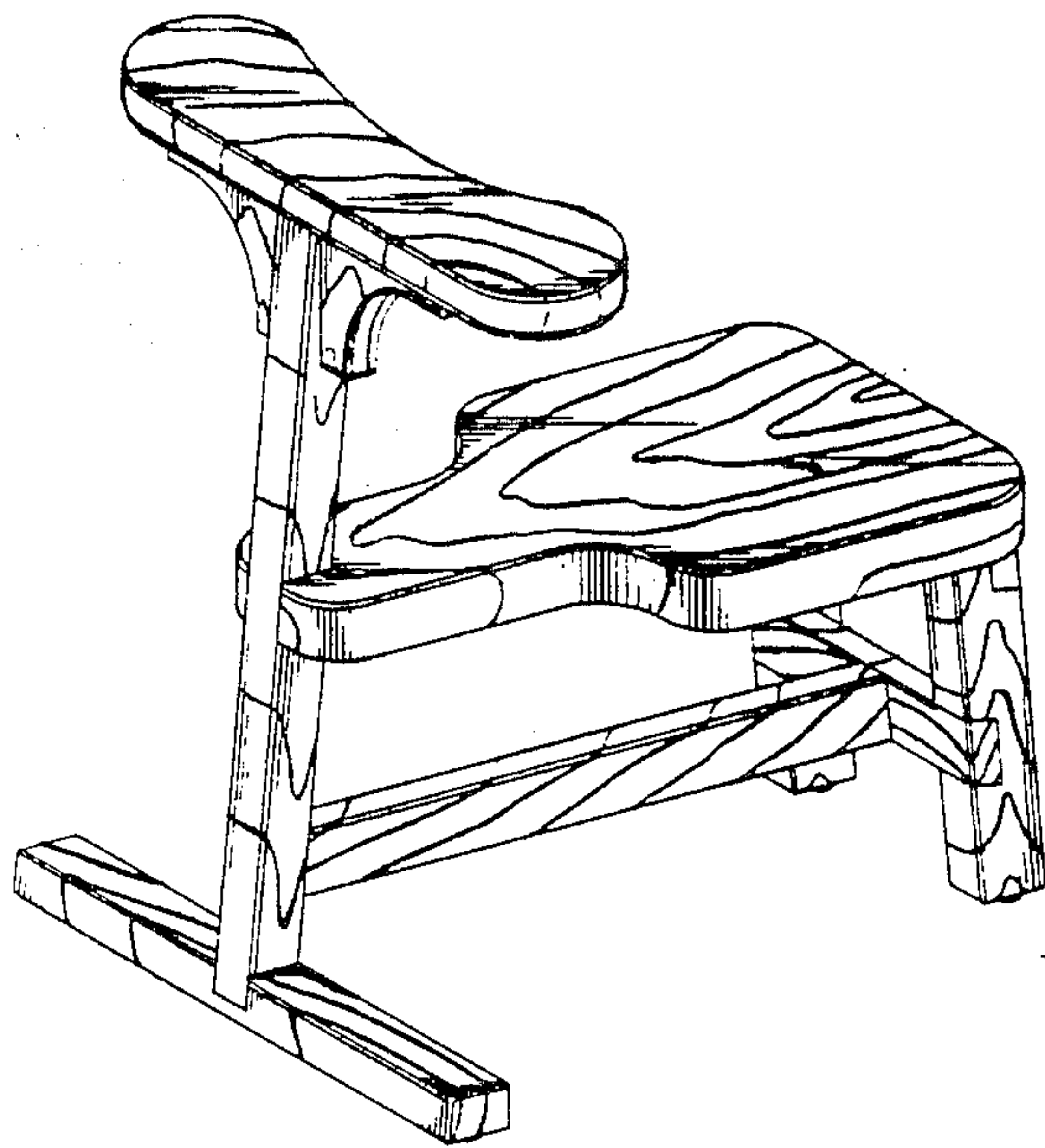

Fig. 1

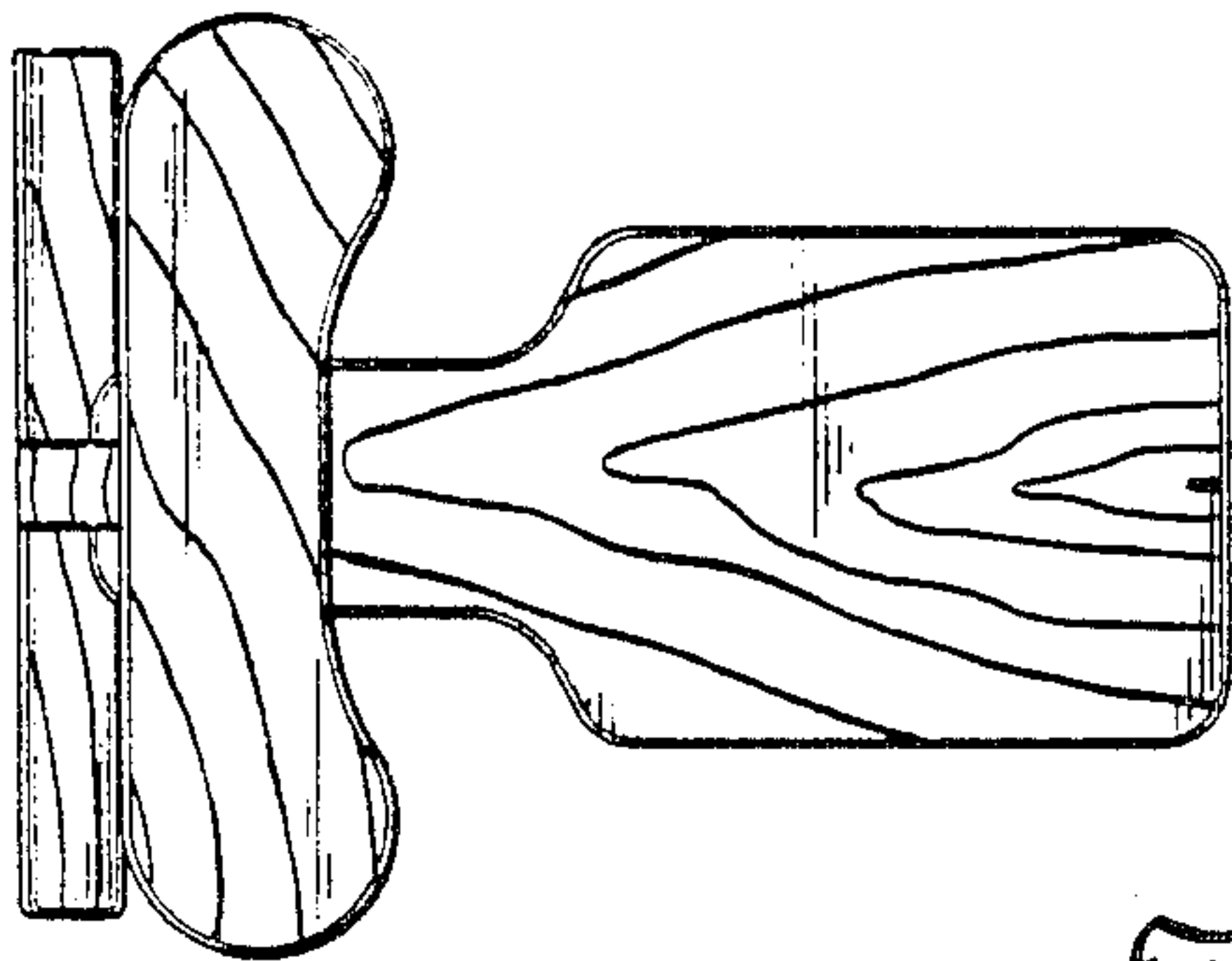

Fig. 2

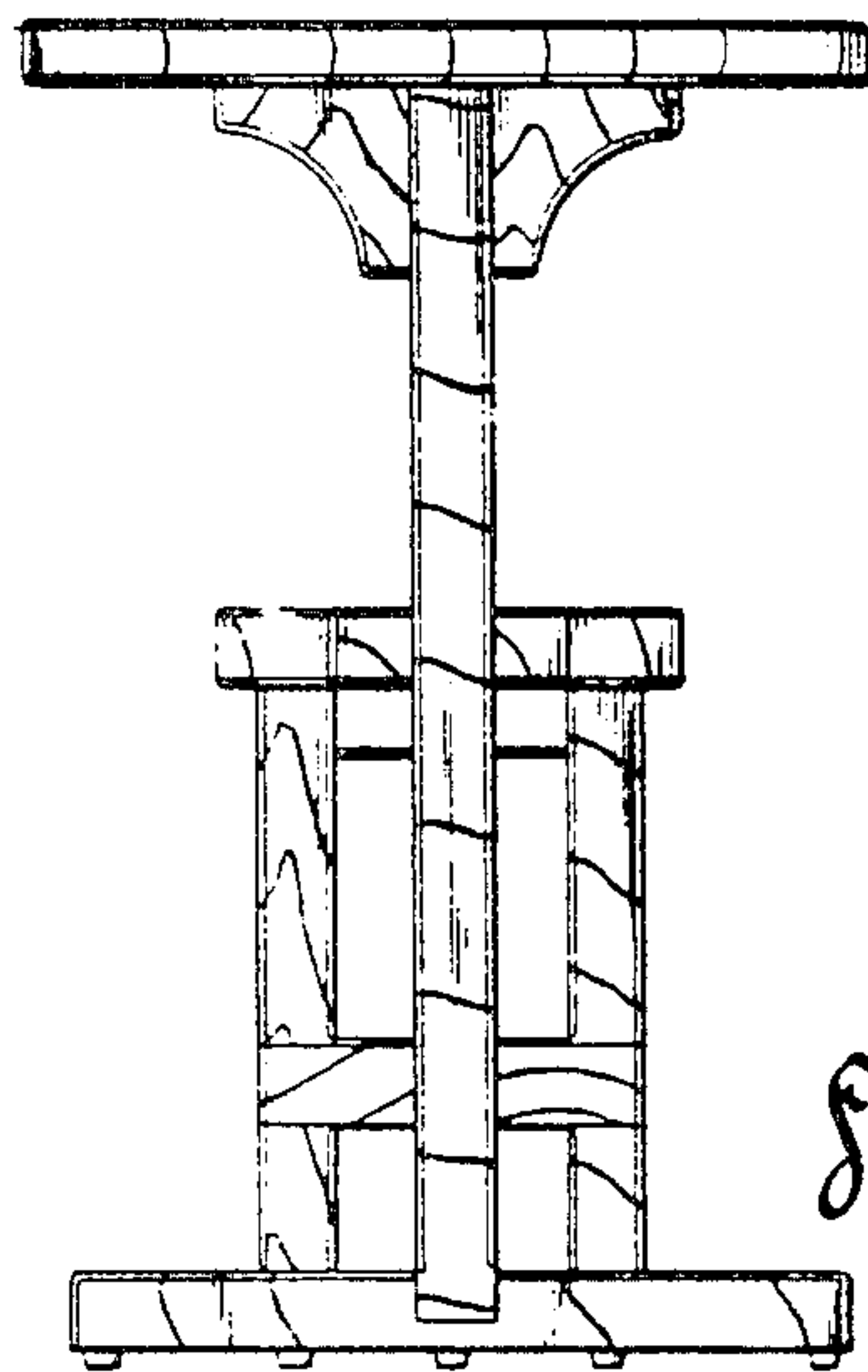

Fig. 3

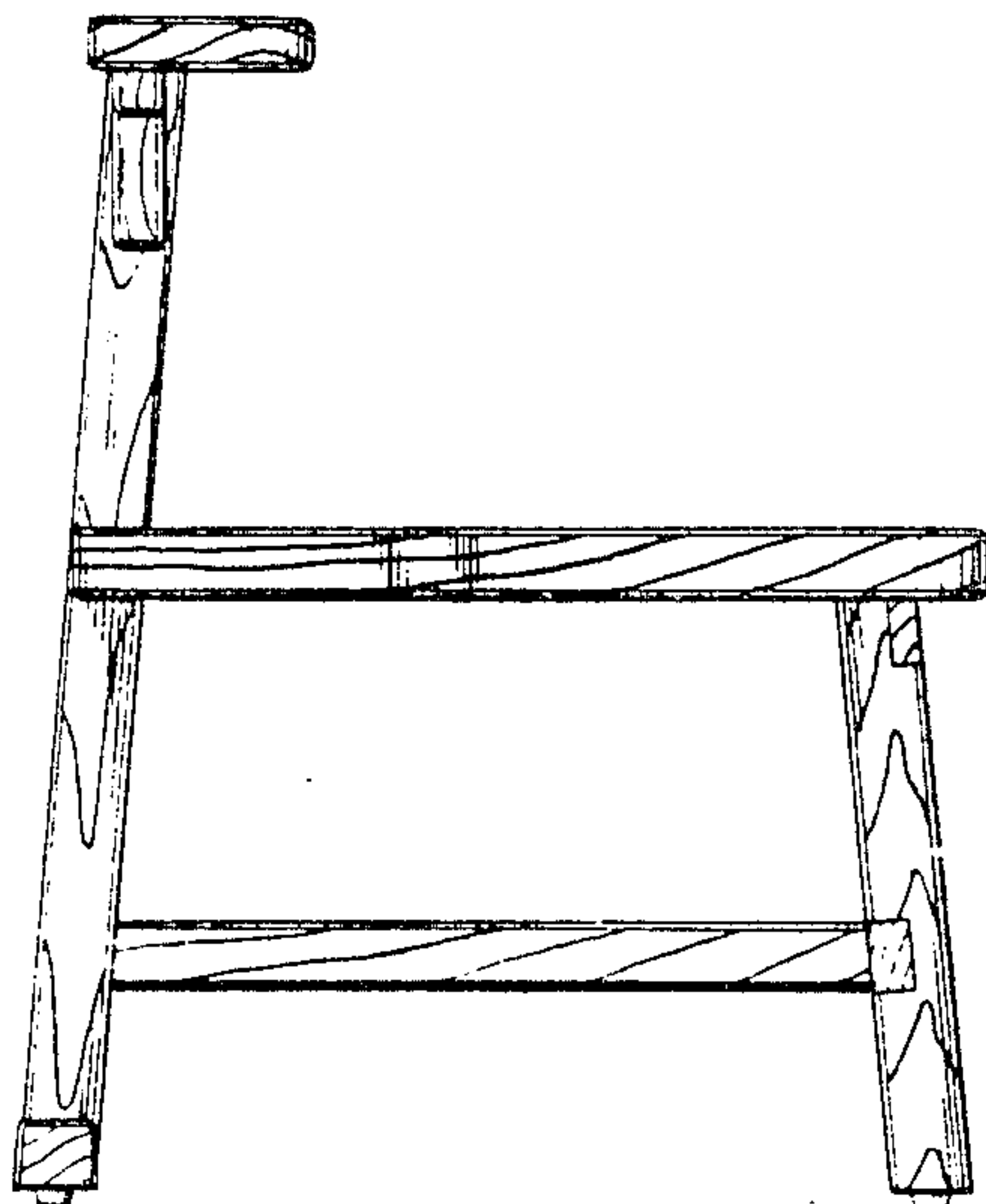

Fig. 4

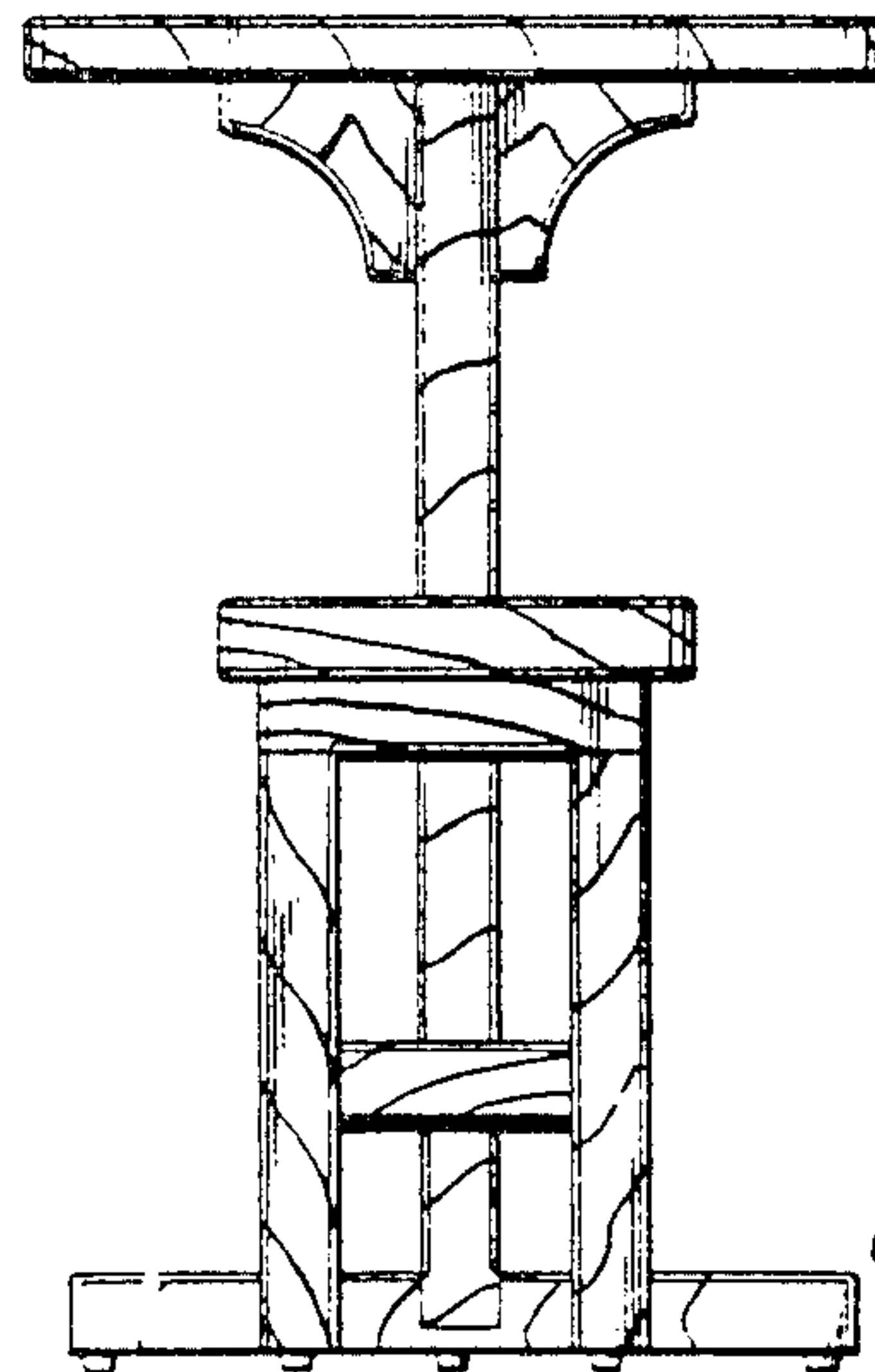

Fig. 5