

[54] **MOTORIZED BUMPER BOAT**

[75] Inventors: **Ralph V. Ball**, Laguna Niguel; **James E. Drake**, El Cajon, both of Calif.

[73] Assignee: **J&J Recreation, Inc.**, San Juan Capistrano, Calif.

[**] Term: **14 Years**

[21] Appl. No.: **441,728**

[22] Filed: **Nov. 15, 1982**

[52] U.S. Cl. **D12/307**

[58] Field of Search **D12/305, 309, 307, 300, D12/311, 313, 314, 316, 306; 114/345, 346; 46/93**

[56] **References Cited**

U.S. PATENT DOCUMENTS

D. 211,499	6/1968	Hofrus	D12/307
D. 235,532	6/1975	Bernard	D12/306
D. 264,707	6/1982	Bettis	D12/309
3,339,514	9/1967	Skuce II	D12/307

FOREIGN PATENT DOCUMENTS

940388 1/1974 Canada 114/270

OTHER PUBLICATIONS

Photographs of "Water Bug" Bumper Boat By Applicant.

Primary Examiner—James M. Gandy

Assistant Examiner—K. H. Chin

Attorney, Agent, or Firm—Knobbe, Martens, et al.

[57] **CLAIM**

The ornamental design for a motorized bumper boat, as shown.

DESCRIPTION

FIG. 1 is a perspective view of the front, top, and left side of a motorized bumper boat showing my new design;

FIG. 2 is a perspective view showing the front and top thereof;

FIG. 3 is a perspective view showing the front, top and right side thereof;

FIG. 4 is an enlarged front elevation view thereof;

FIG. 5 is an enlarged rear elevation view thereof; and

FIG. 6 is an enlarged left elevation view thereof.

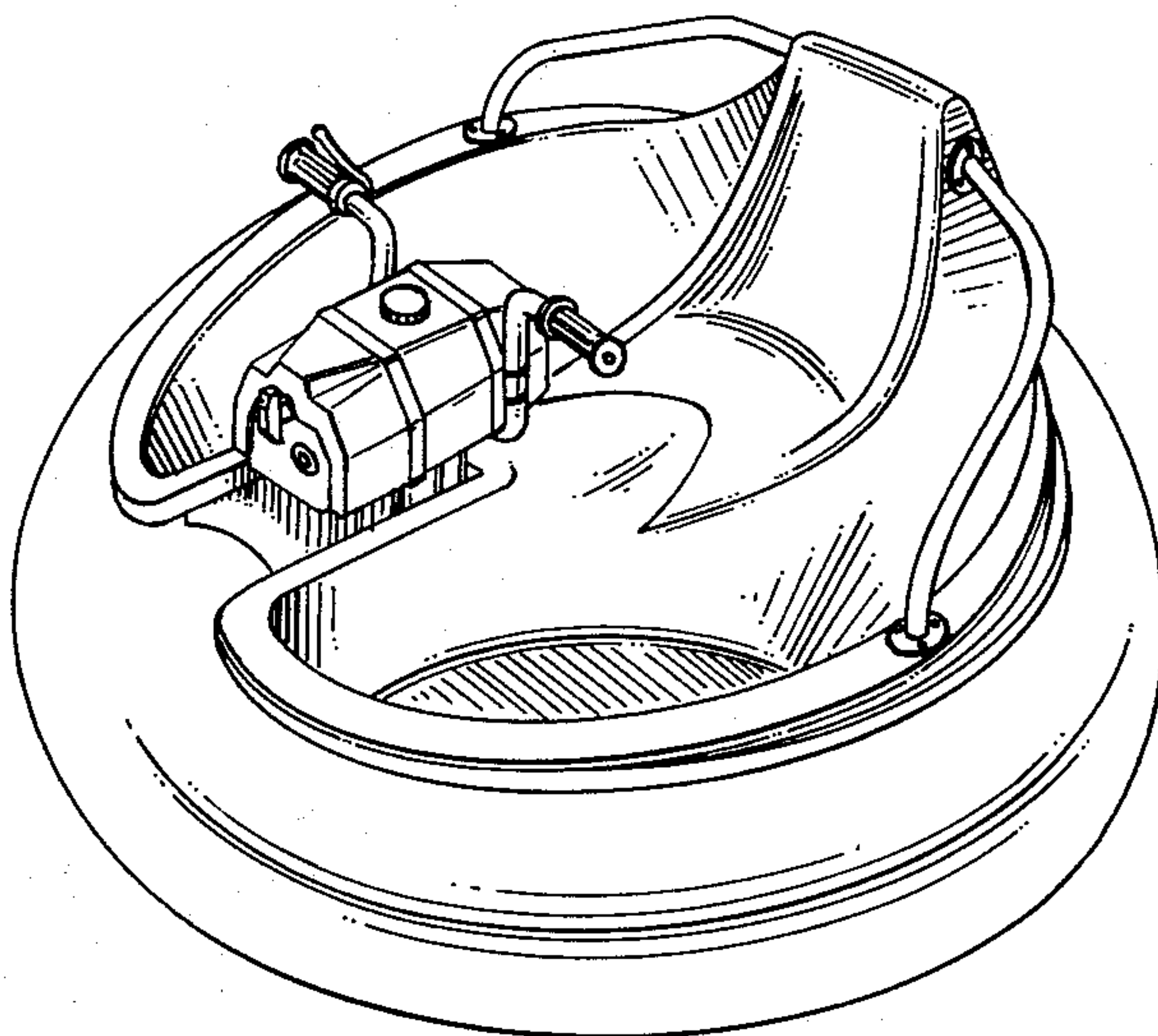

FIG. 1

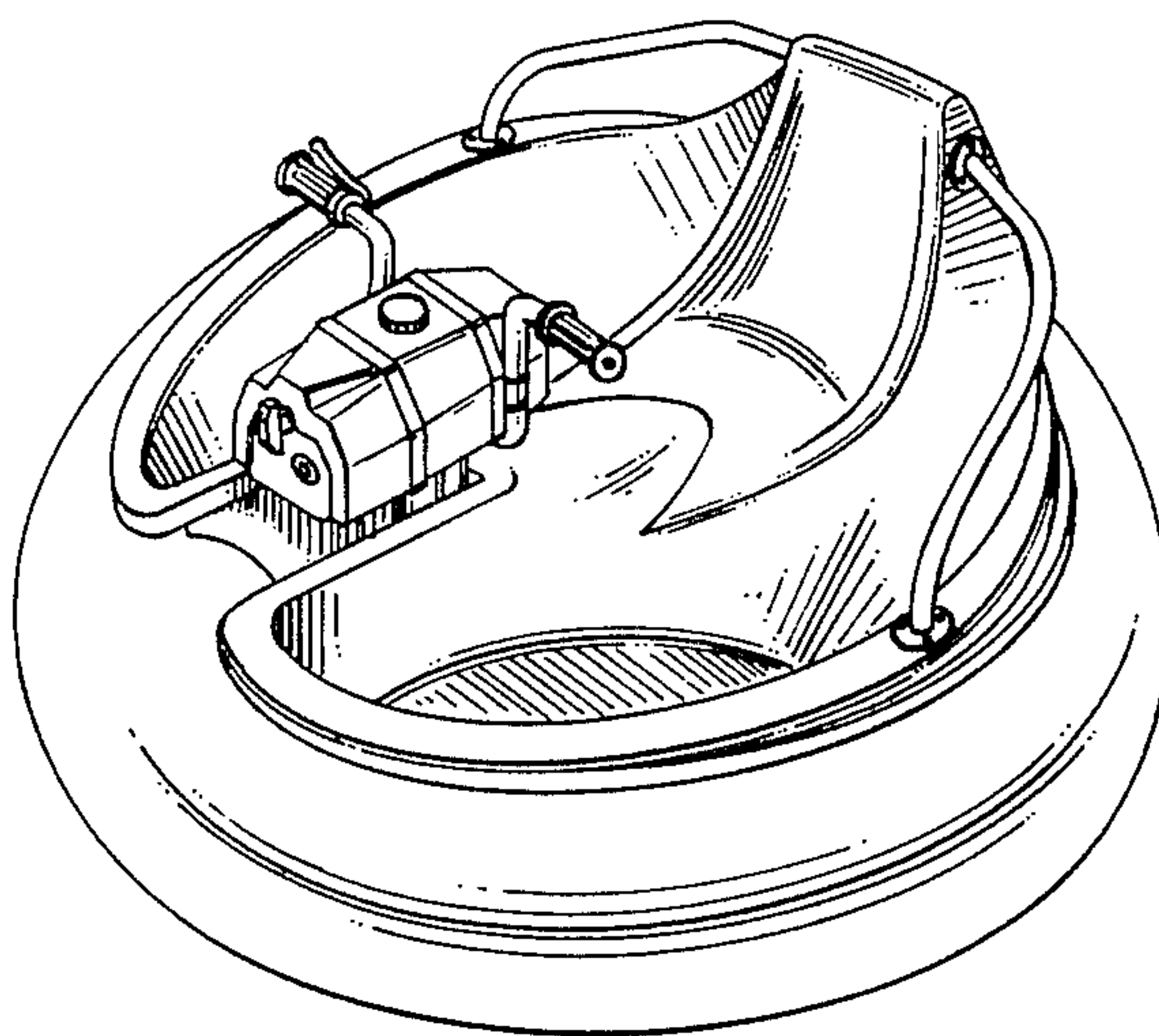

FIG. 2

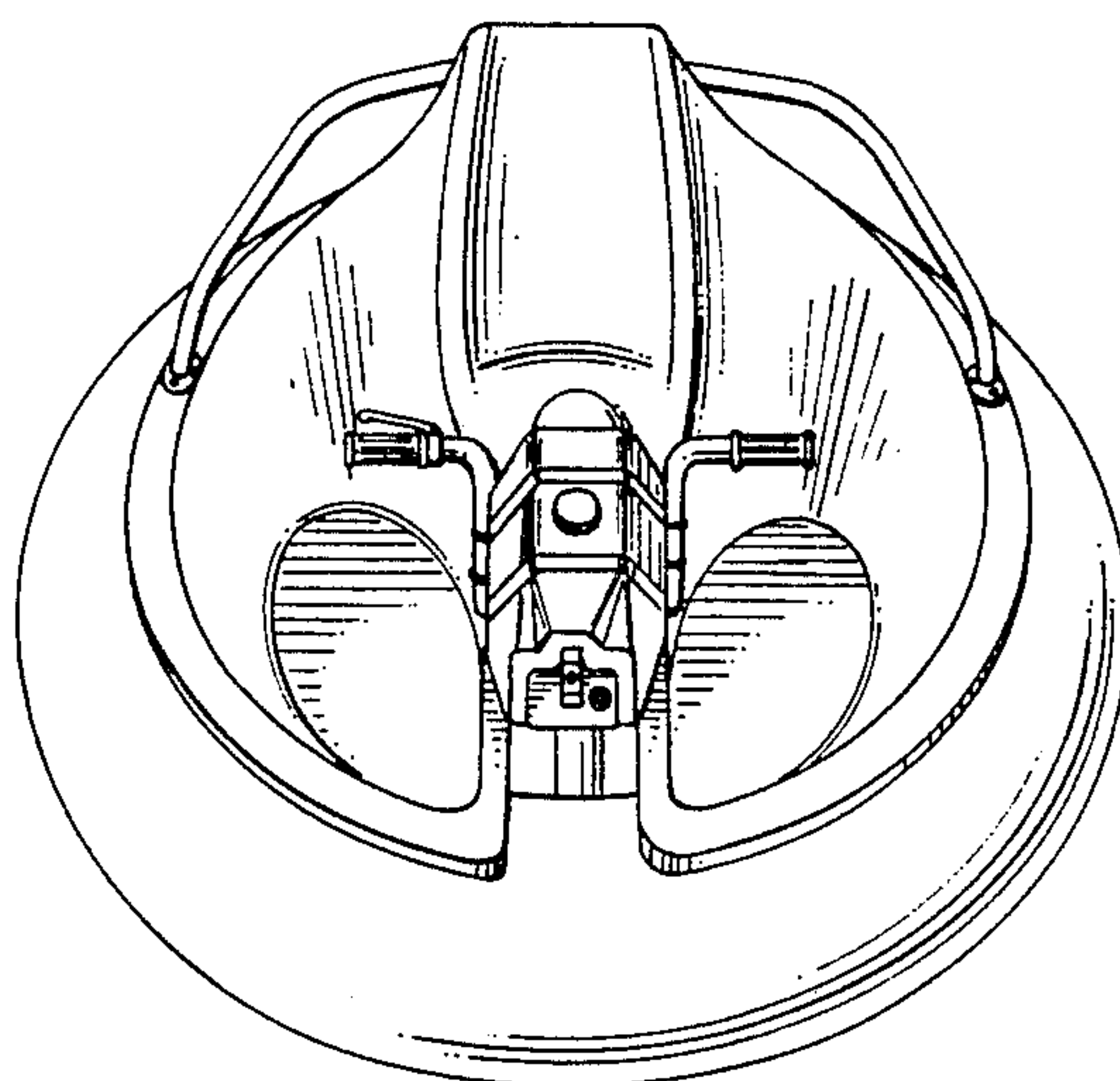

FIG. 3

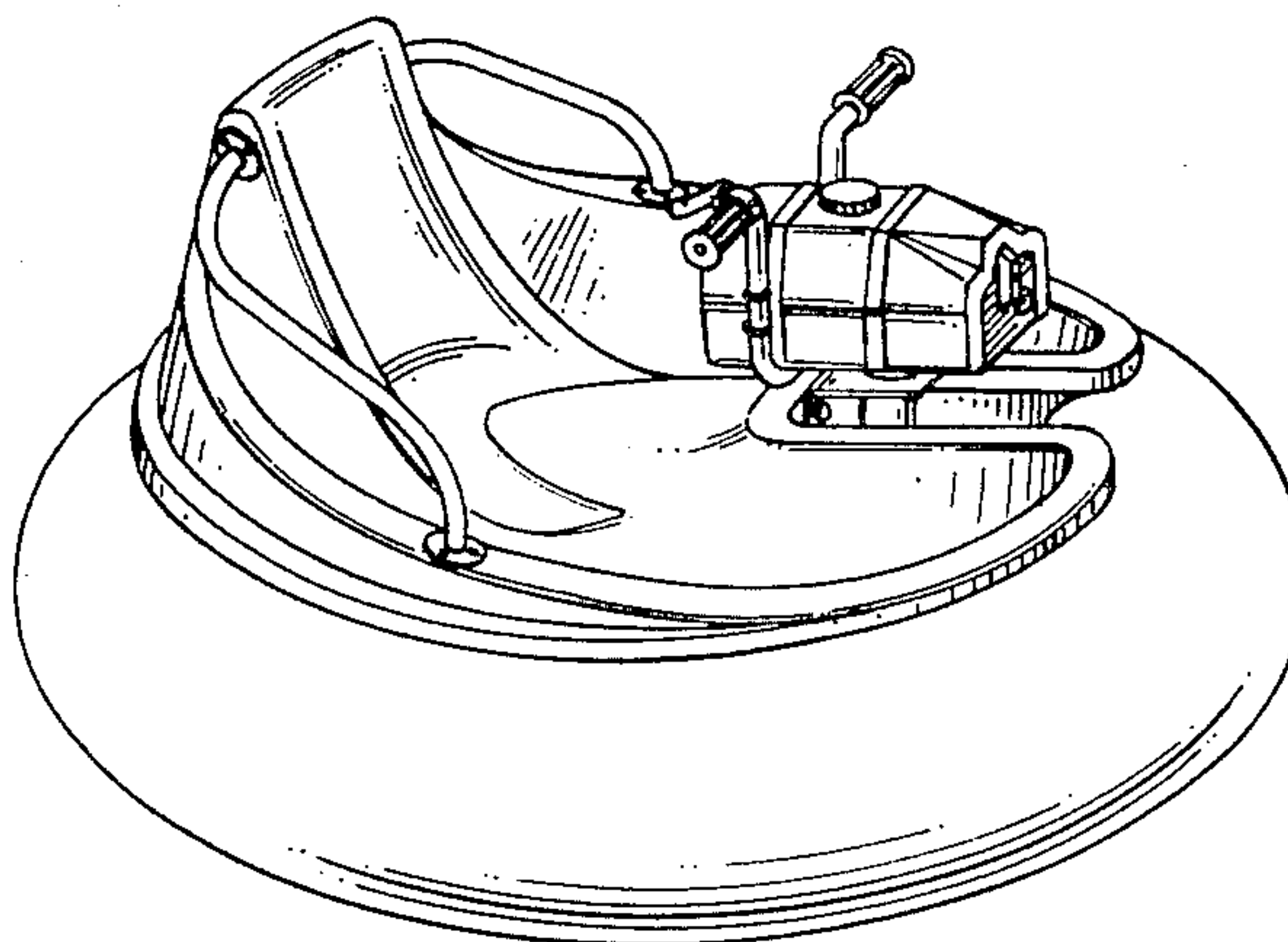

FIG. 4

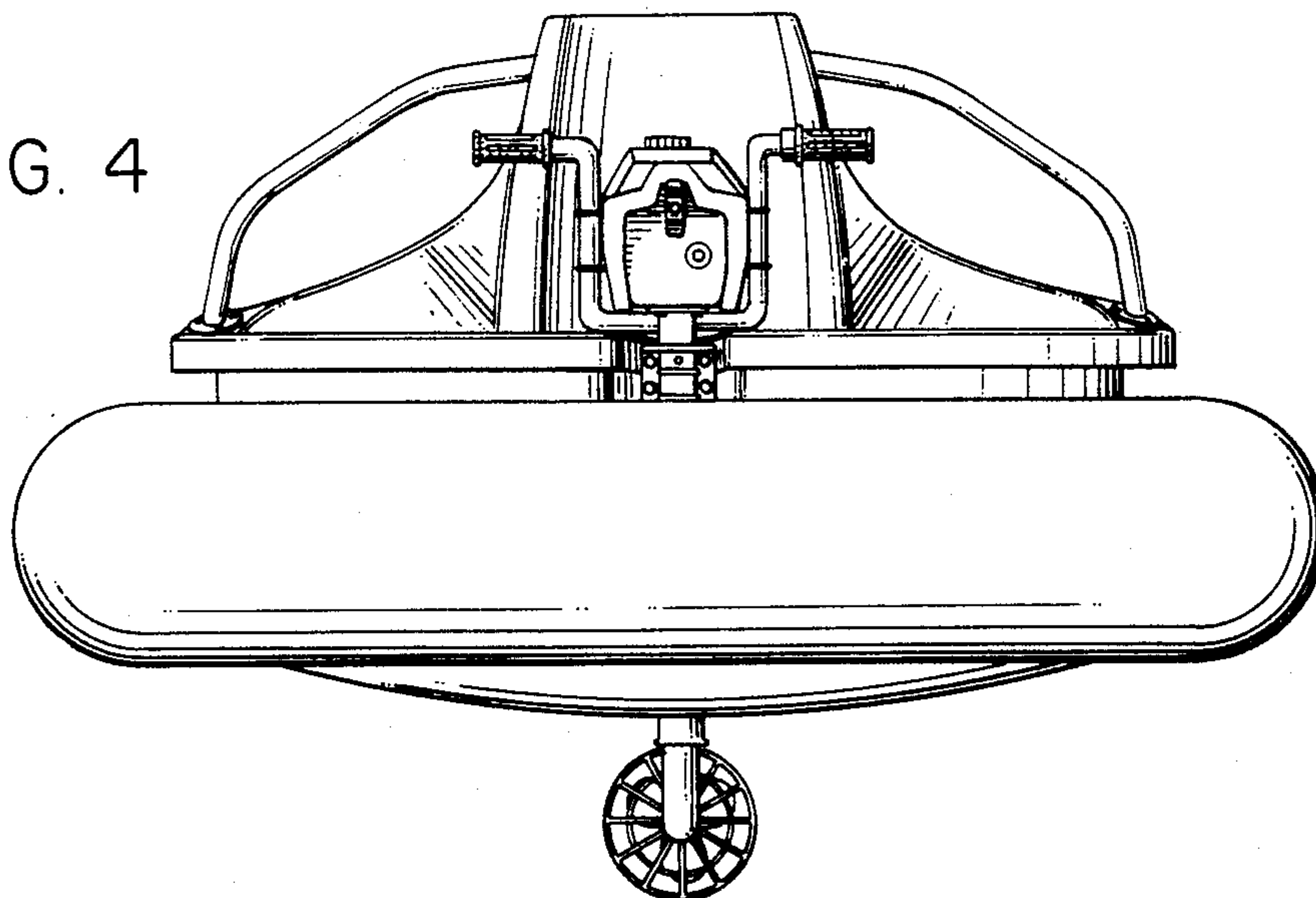

FIG. 5

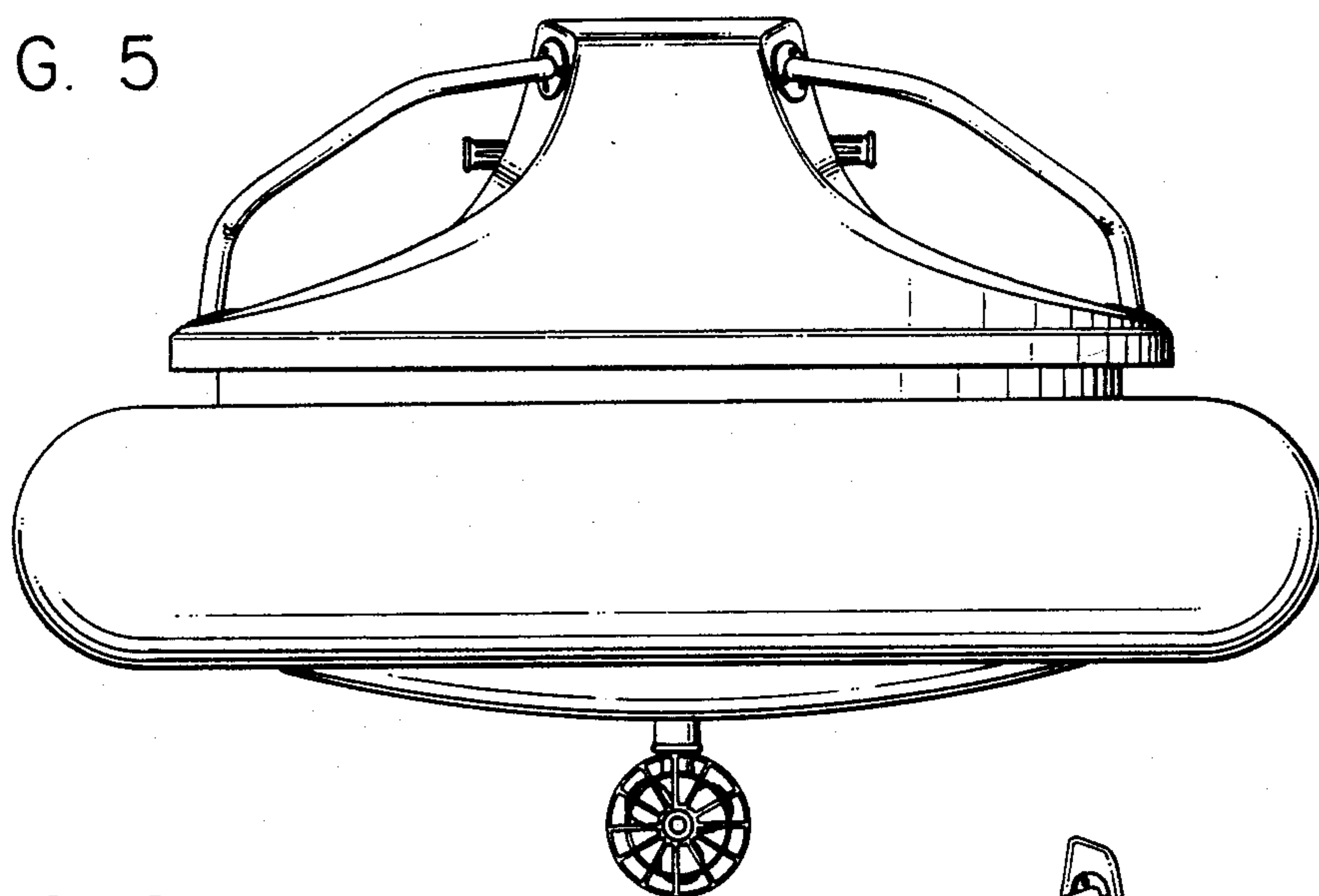

FIG. 6

