

[54] VEHICLE WHEEL CENTER

[76] Inventor: **Raymond J. Hedlund**, 1250 Pinecreek Way, Concord, Calif. 94520

[\*\*] Term: **14 Years**

[21] Appl. No.: **448,155**

[22] Filed: **Dec. 9, 1982**

[52] U.S. Cl. .... **D12/211**

[58] Field of Search ..... D12/209, 210, 211, 135;  
301/63 R, 64 R, 64 SD, 65, 66

[56] **References Cited**

**U.S. PATENT DOCUMENTS**

D. 85,952	1/1932	Miller	.....	D12/135
D. 204,256	4/1966	Rader	.....	D12/211
D. 204,669	5/1966	Goodwin	.....	D12/209
D. 206,432	12/1966	Reid	.....	D12/209
D. 213,314	2/1969	Reid	.....	D12/209
D. 231,732	6/1974	Ishibashi	.....	D12/209

**OTHER PUBLICATIONS**

American Bicyclist & Motorcyclist, 4/81, p. 93, Sprocket Wheel, center of page.

*Primary Examiner*—James M. Gandy  
*Attorney, Agent, or Firm*—Ralph J. Skinkiss; David L. Kuhn

[57] **CLAIM**

The ornamental design for a vehicle wheel center, substantially as shown and described.

**DESCRIPTION**

FIG. 1 is a left, front perspective view of a vehicle wheel center showing my new design, it being understood that the broken lines are for illustrative purposes only.

FIG. 2 is a front elevational view thereof.

FIG. 3 is a sectional view taken along line 3—3 in FIG. 2 it being understood that the bolt and nut assembly have not been shown in section for ease of illustration.

FIG. 4 is a sectional view taken along line 4—4 in FIG. 2.

FIG. 5 is a sectional view taken along line 5—5 in FIG. 2.

FIG. 6 is a sectional view taken along line 6—6 in FIG. 2.

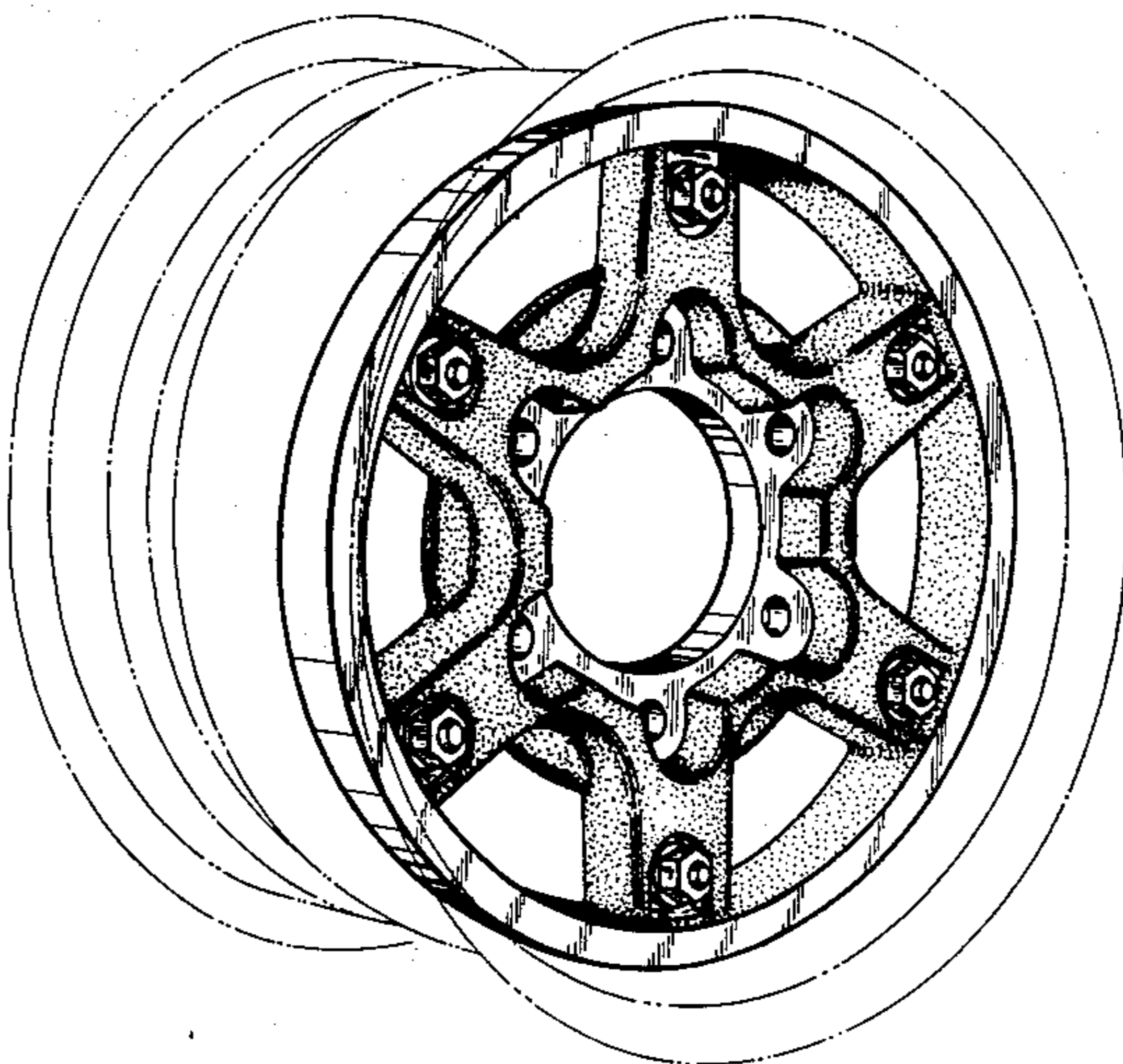

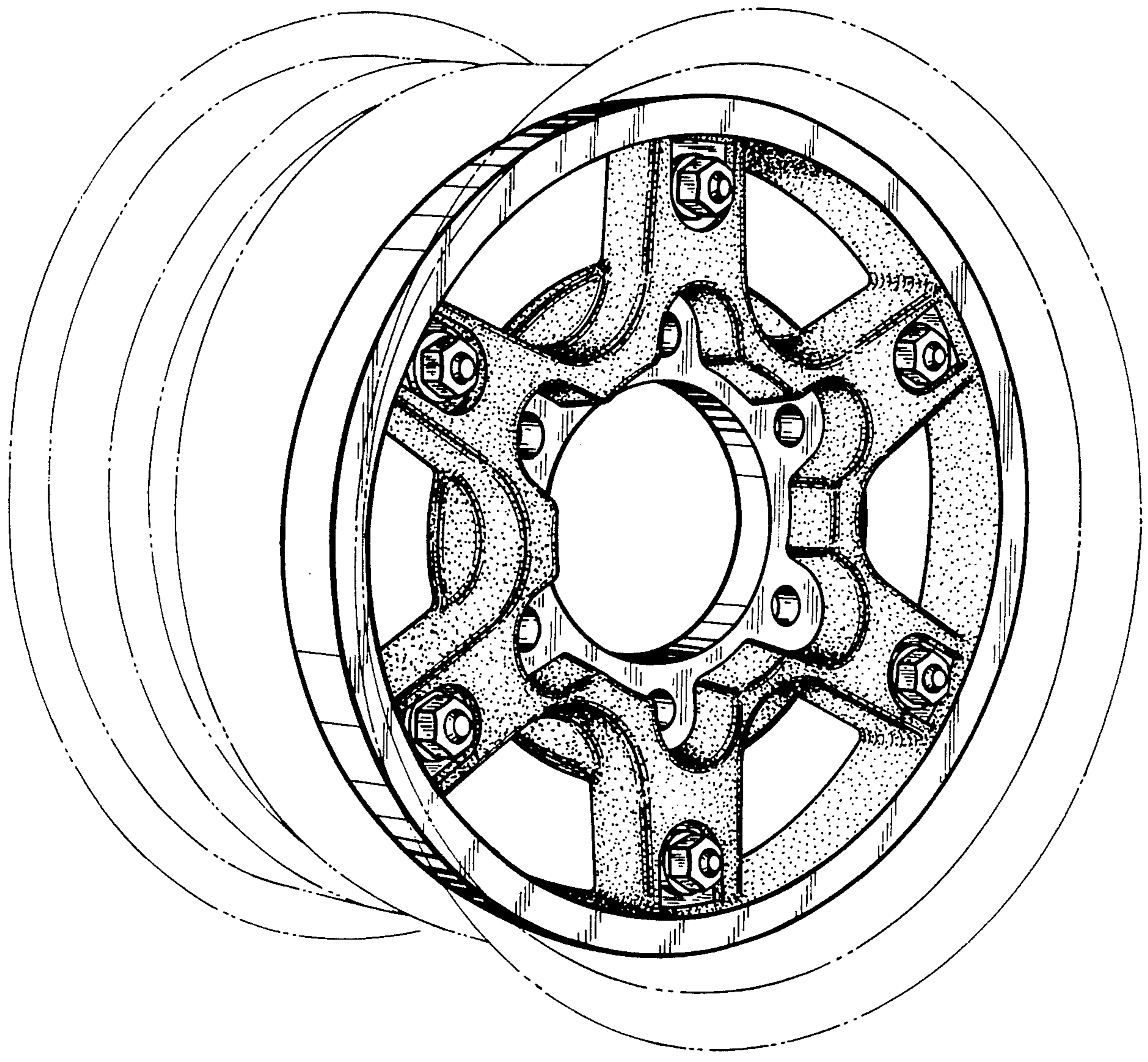

—FIG. 1

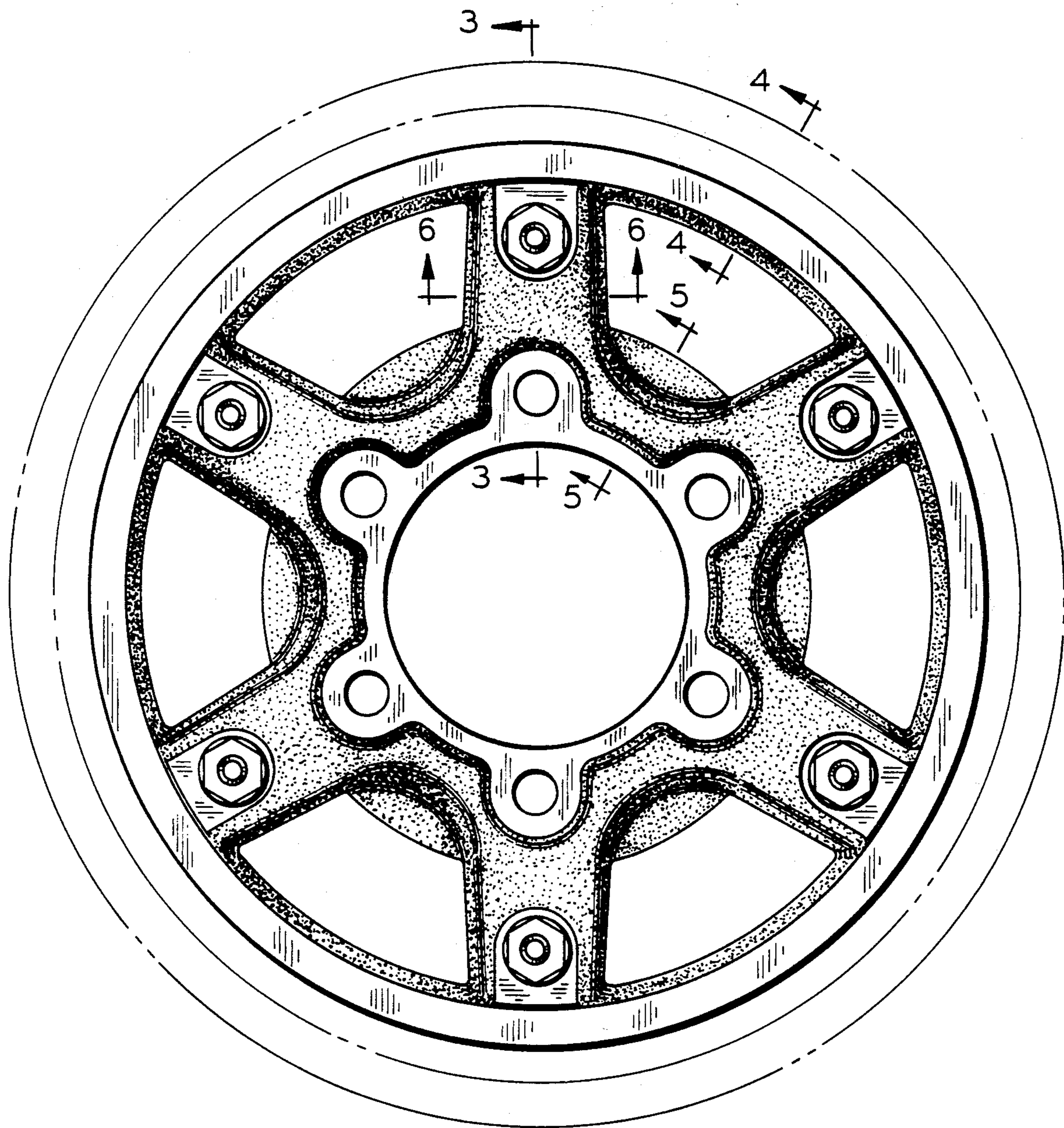

—FIG. 2

