

[54] COMBINED TAPE DECK, PHONOGRAPH, TUNER AND AMPLIFIER

[75] Inventors: Takao Oura; Hideki Okada, both of Kamakura, Japan

[73] Assignee: Mitsubishi Denki Kabushiki Kaisha, Tokyo, Japan

[**] Term: 14 Years

[21] Appl. No.: 444,815

[22] Filed: Nov. 23, 1982

[30] Foreign Application Priority Data

Jul. 5, 1982 [JP] Japan 57-30278

[52] U.S. Cl. D14/5; D14/6; D14/20; D14/22; D14/72; D14/96

[58] Field of Search D14/1, 2, 5, 6, 14, D14/17, 20, 22, 25, 72, 99, 96

[56] References Cited

U.S. PATENT DOCUMENTS

- D. 228,025 7/1973 Askin D14/17
- D. 251,423 3/1979 Takanashi et al. D14/2
- D. 268,929 5/1983 Tsuruta et al. D14/22 X

OTHER PUBLICATIONS

High Fidelity, 10-81, p. 25, Akai GX-77.
High Fidelity, 11-81, p. 14, Mitsubishi LT-5V.

Primary Examiner—Jane E. Corrigan
Attorney, Agent, or Firm—Wenderoth, Lind & Ponack

[57] CLAIM

The ornamental design for a combined tape deck, phonograph, tuner and amplifier, substantially as shown and described.

DESCRIPTION

FIG. 1 is a front elevational view of a combined tape deck, phonograph, tuner and amplifier showing our new design;
 FIG. 2 is a rear elevational view thereof;
 FIG. 3 is a top plan view thereof;
 FIG. 4 is a bottom plan view thereof;
 FIG. 5 is a left side elevational view thereof;
 FIG. 6 is a right side elevational view thereof;
 FIG. 7 is a front, top and right side perspective view thereof; and
 FIG. 8 is a view like FIG. 7 with the cover in opened position.

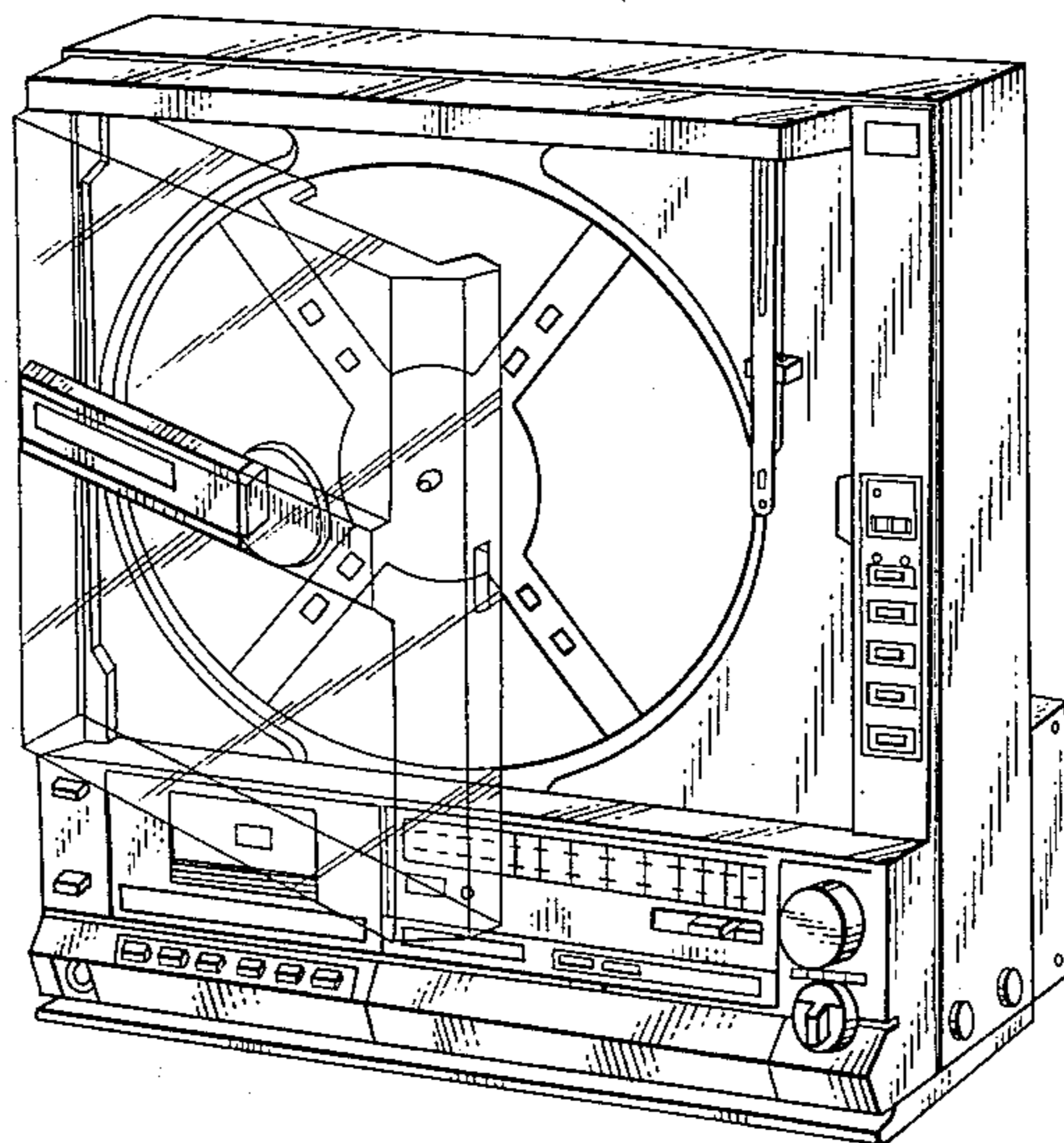

FIG. 1

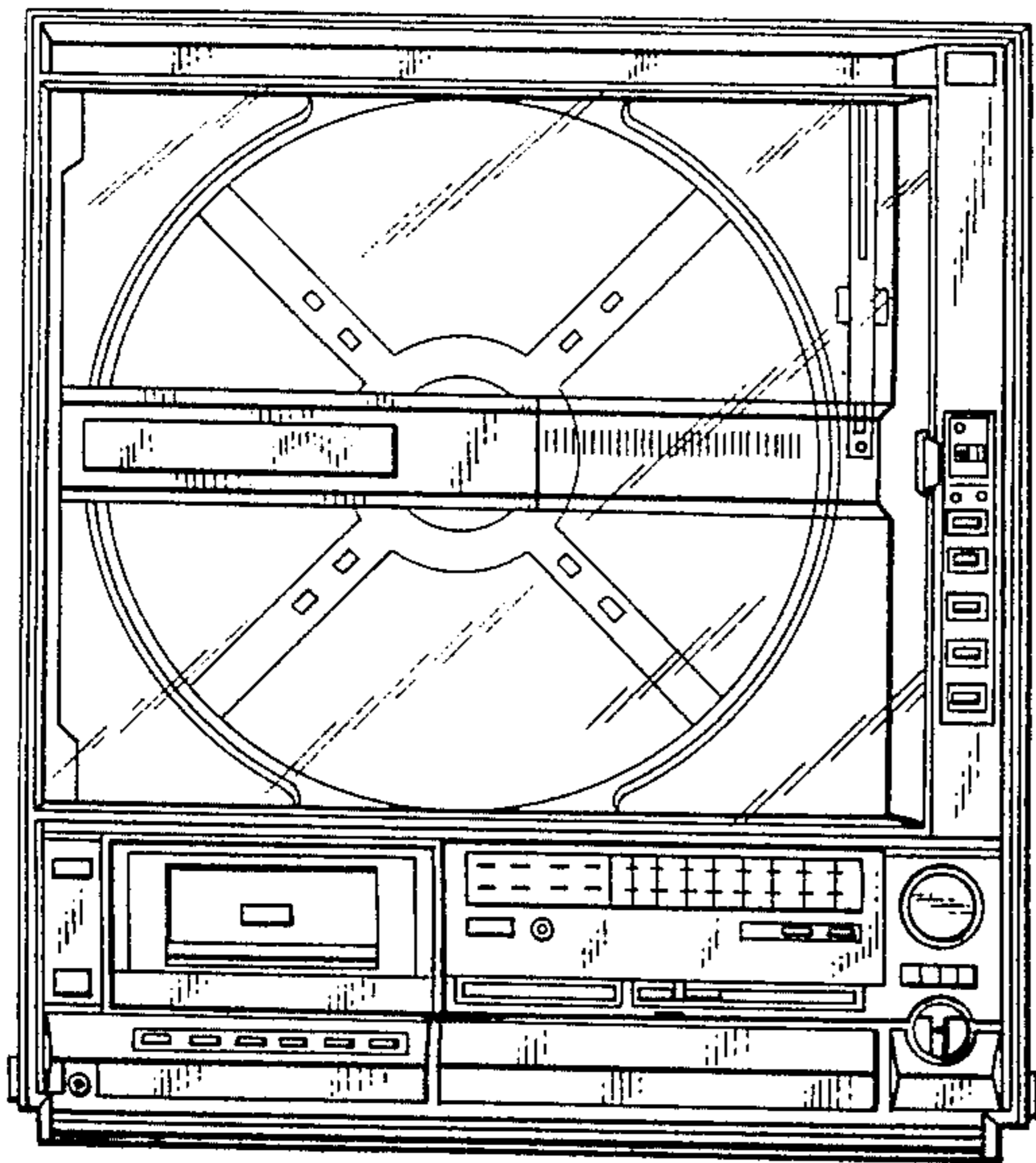

FIG. 2

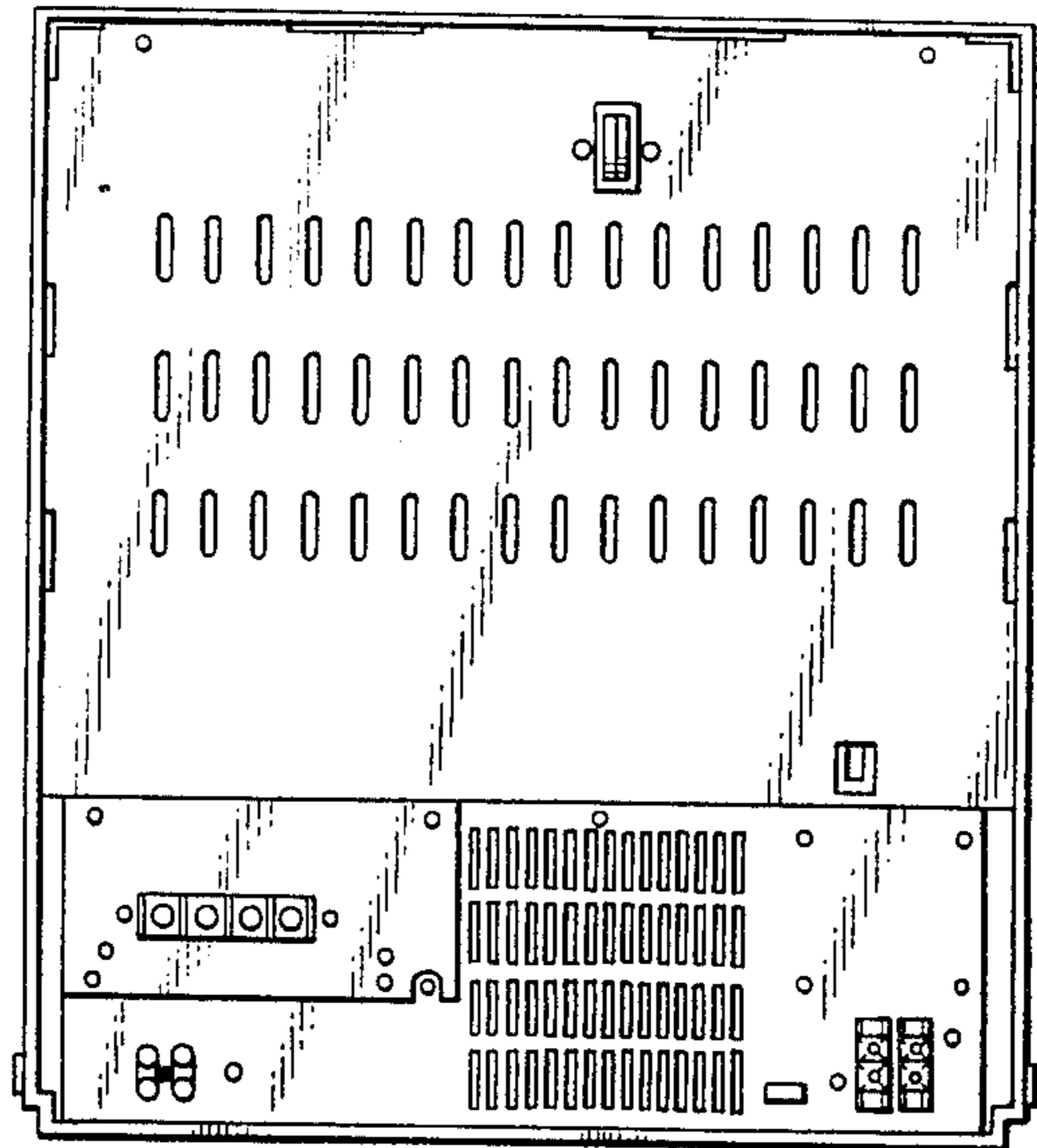

FIG. 3

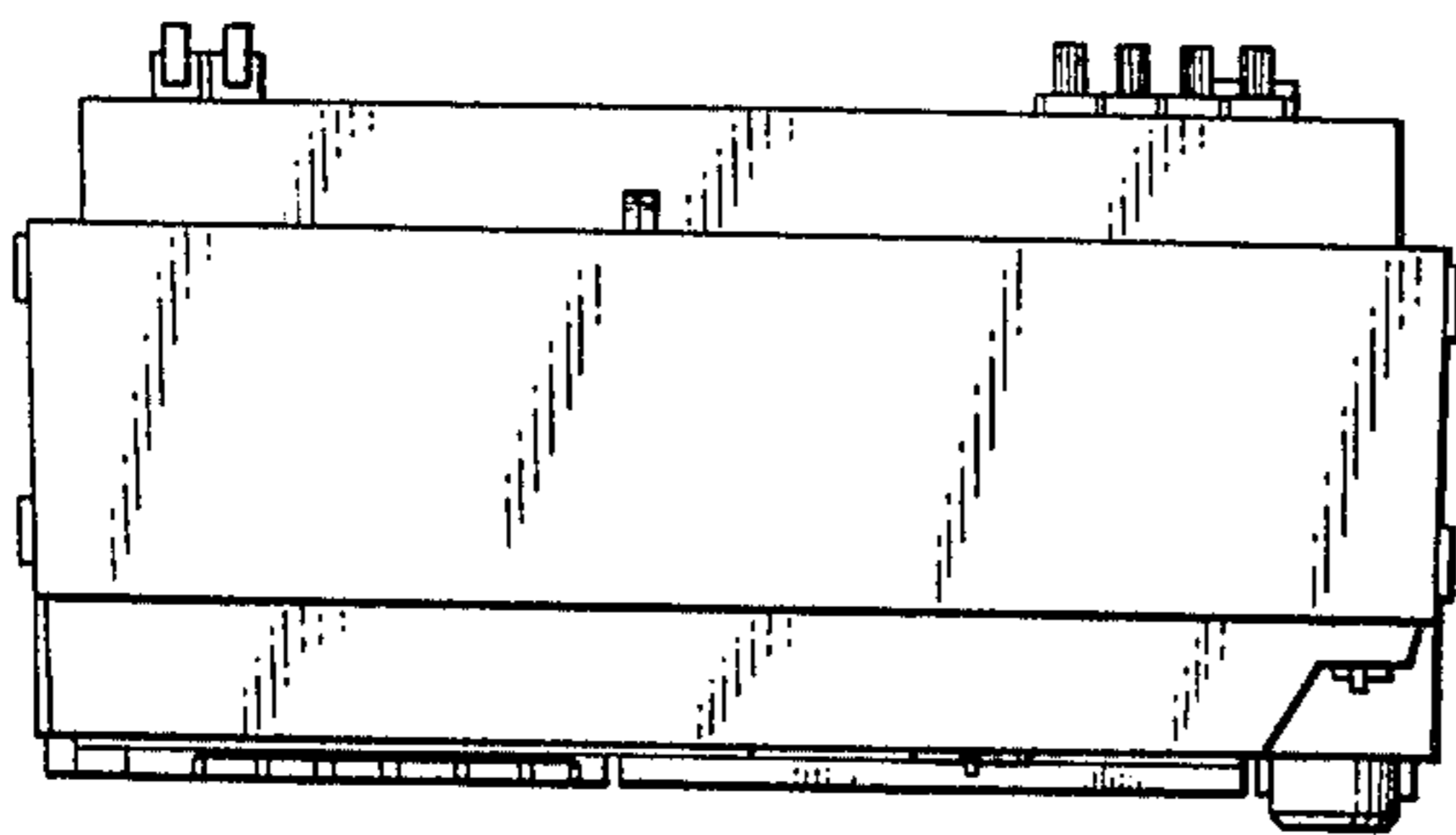

FIG. 4

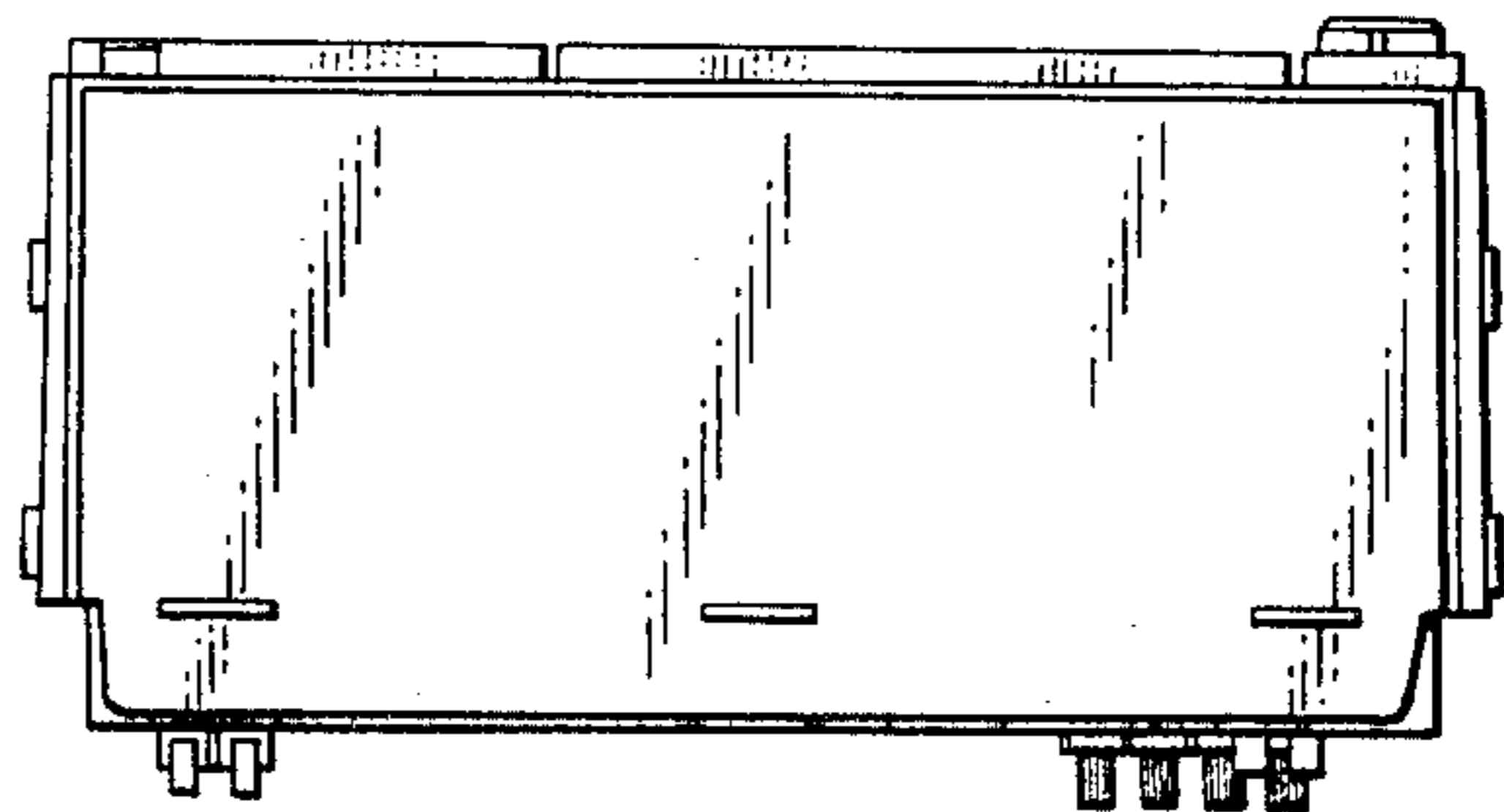

FIG. 5

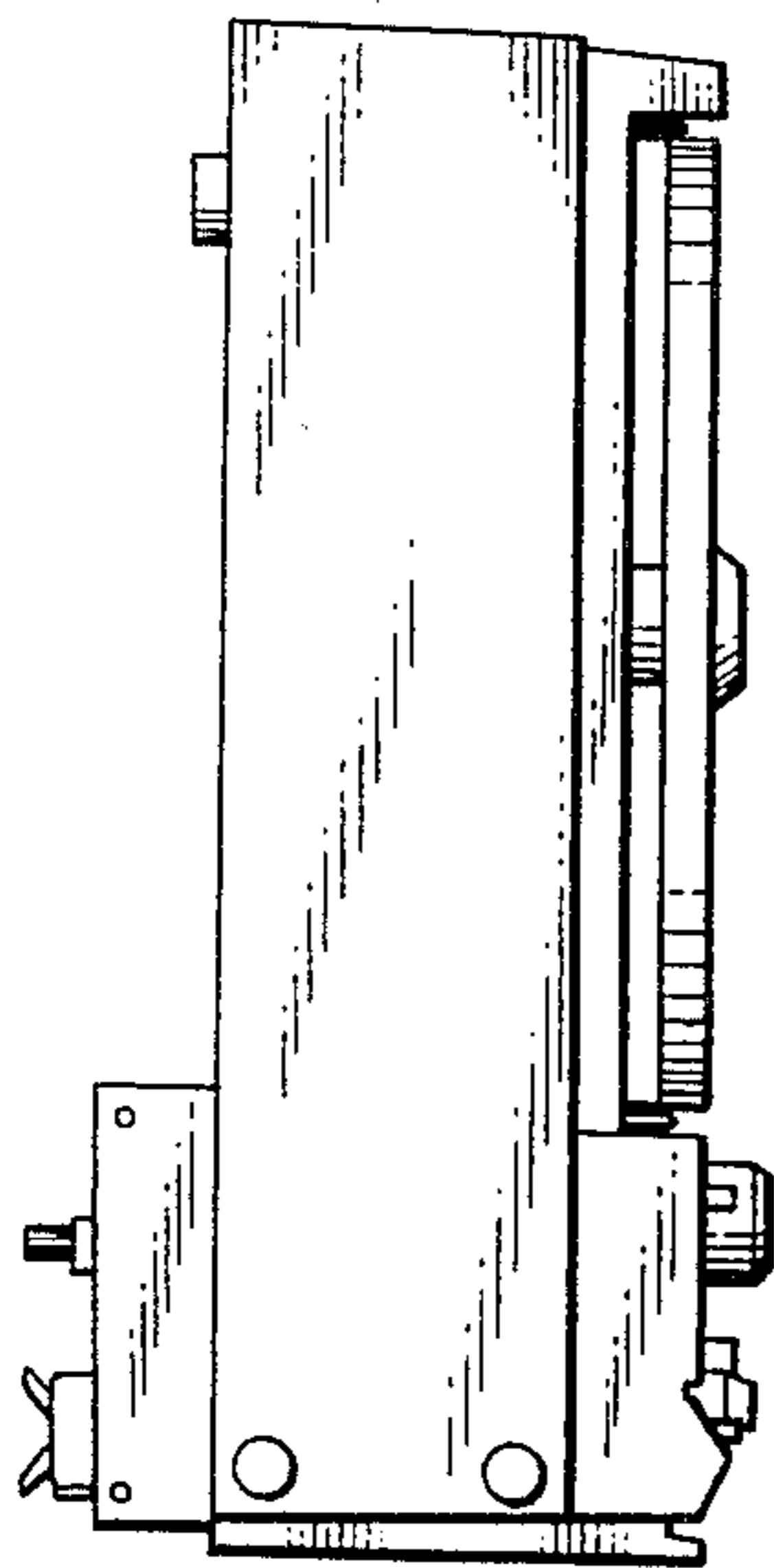

FIG. 6

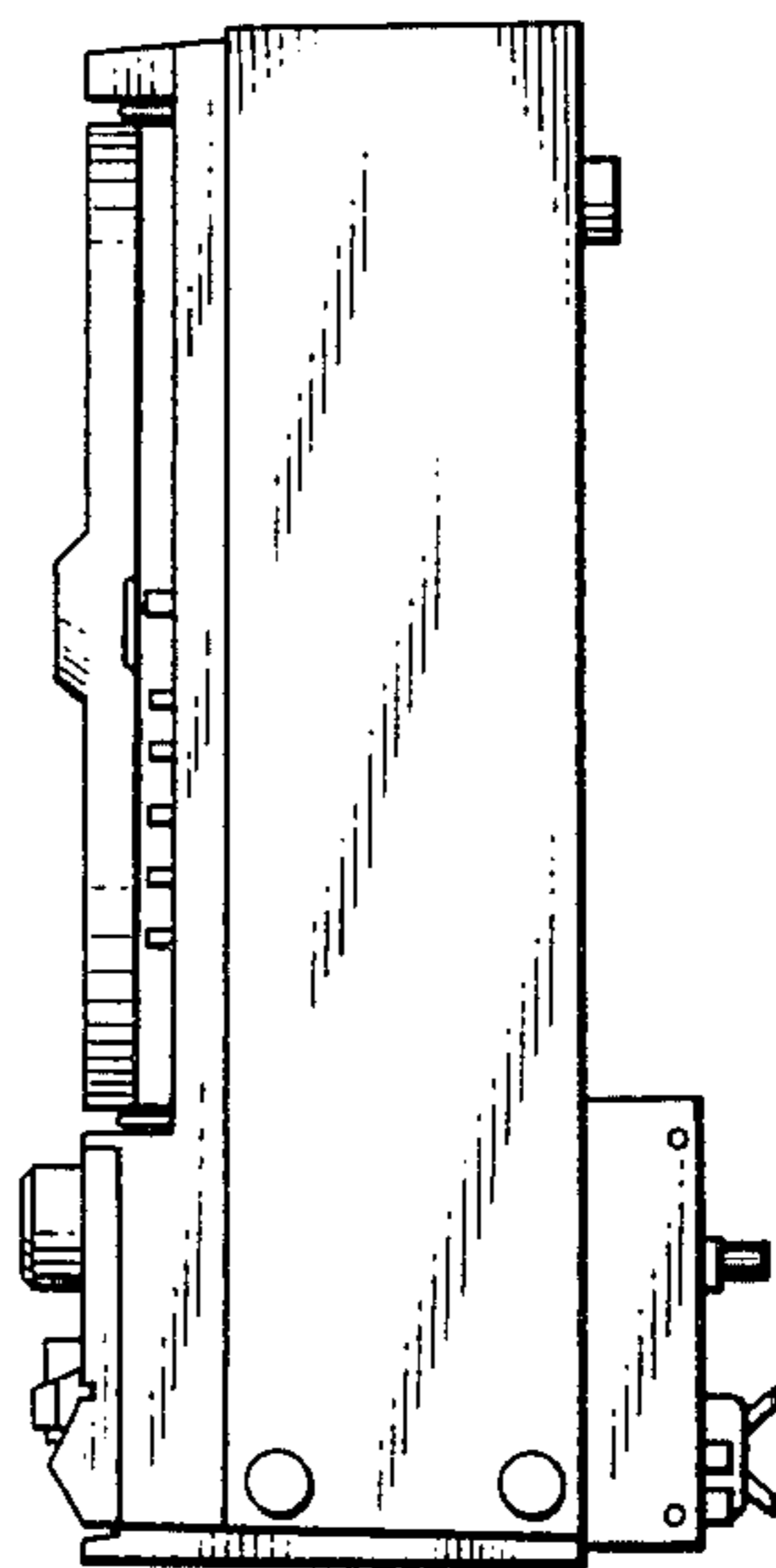

FIG. 7

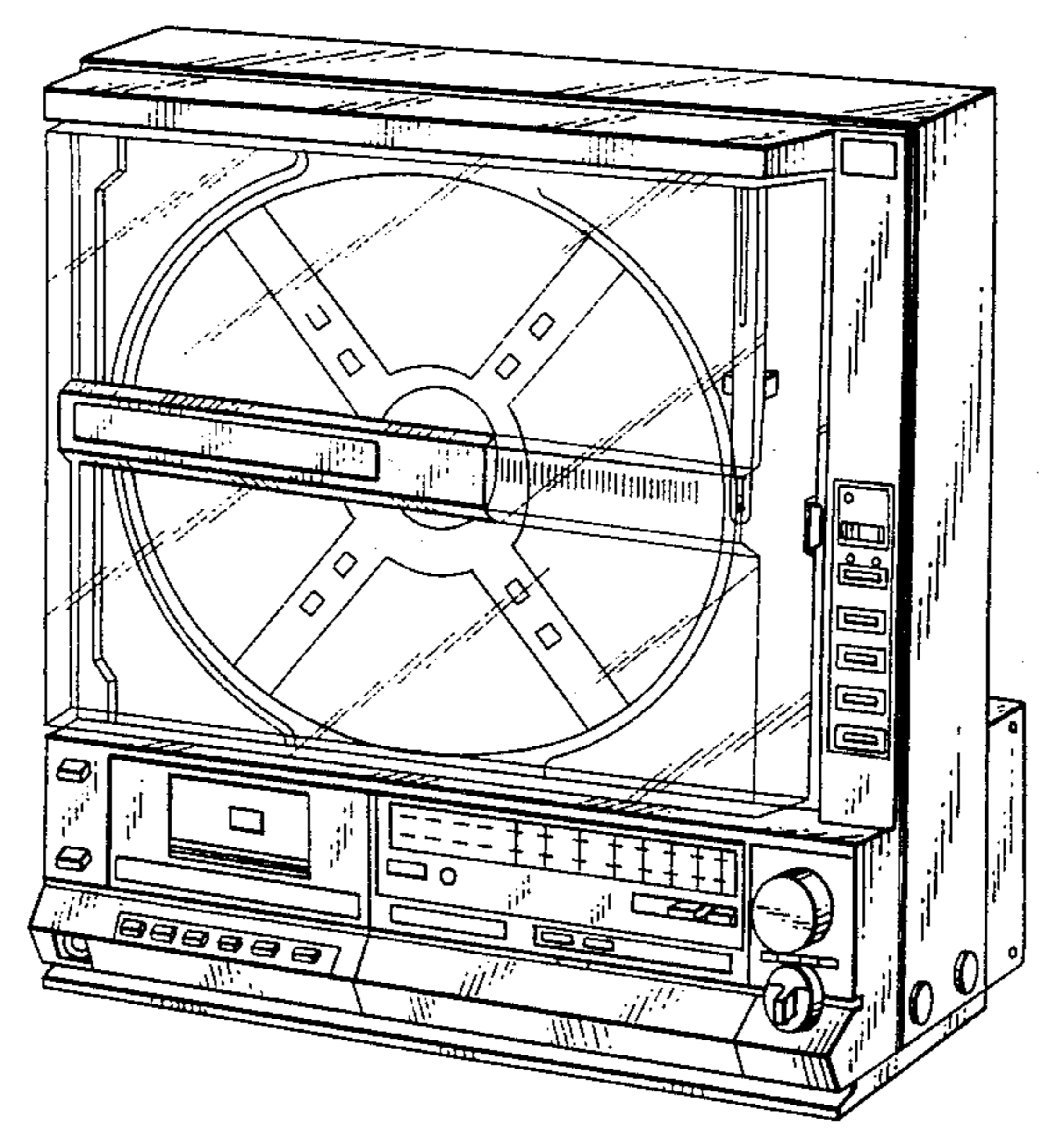

FIG. 8

