

[54] CHAIR

[76] Inventor: Charles R. Pollock, 34-24 86th St., Jackson Heights, N.Y. 11372

[\*\*] Term: 14 Years

[21] Appl. No.: 418,511

[22] Filed: Sep. 15, 1982

[52] U.S. Cl. .... D6/373

[58] Field of Search ..... D6/47, 78

[56] References Cited

U.S. PATENT DOCUMENTS

- D. 226,747 4/1973 Koepke ..... D6/69
- 3,847,433 11/1974 Acton et al. .... D6/69 X
- 3,941,416 3/1976 Uchida ..... D6/69 X

Primary Examiner—Bruce W. Dunkins  
Attorney, Agent, or Firm—Kane, Dalsimer, Kane, Sullivan & Kurucz

[57] CLAIM

The new and ornamental design for a chair, substantially as shown and described.

DESCRIPTION

FIG. 1 is a frontal and left side perspective view of the chair showing my new design; the right side portion being a mirror image of the left side portion; FIG. 2 is a rear slightly elevated view illustrating the rear, top and left side portions of the chair, the right side portion being a mirror image of the left side portion; and FIG. 3 is a rear perspective view similar to FIG. 2 except at a more rearward and elevated angle.

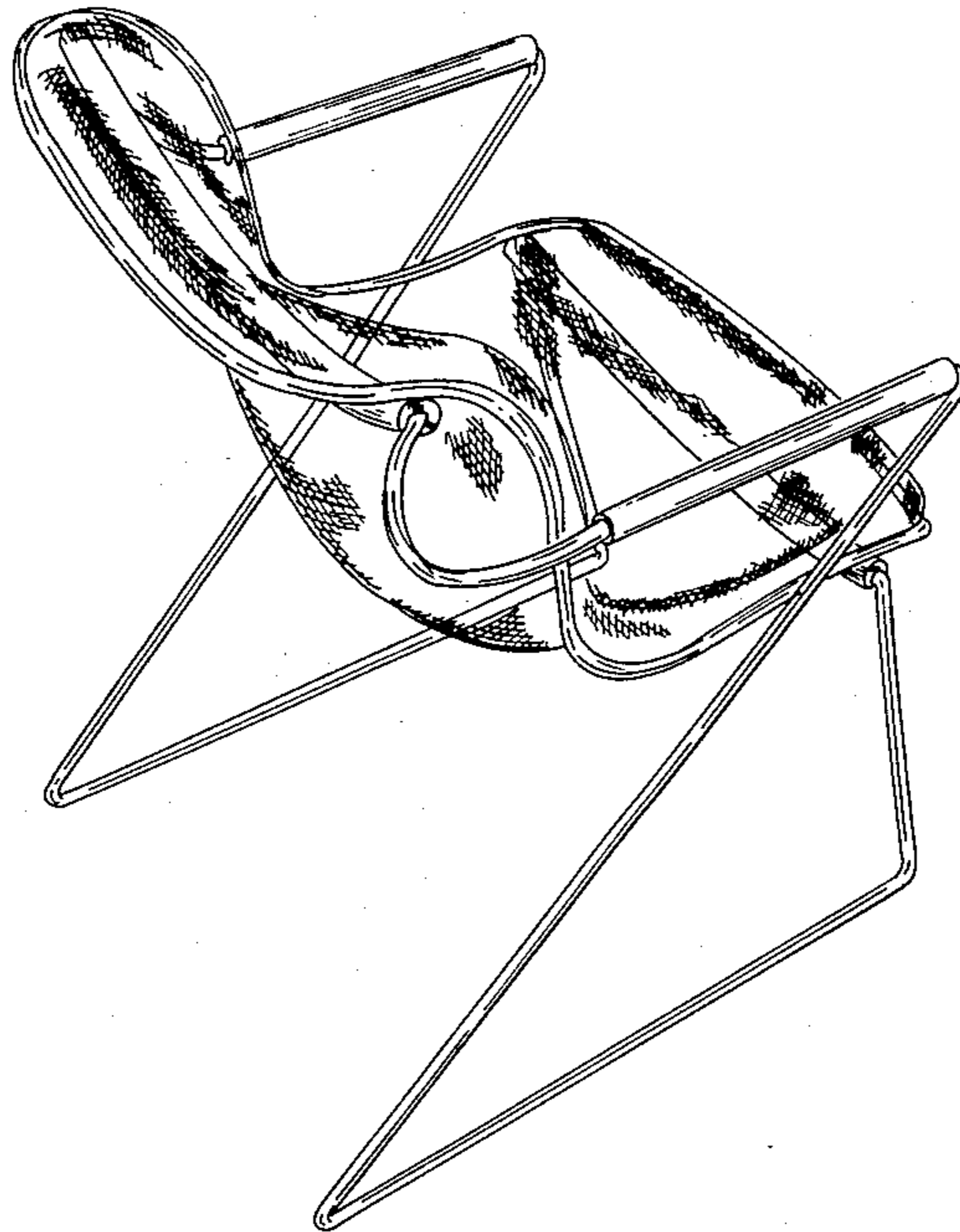

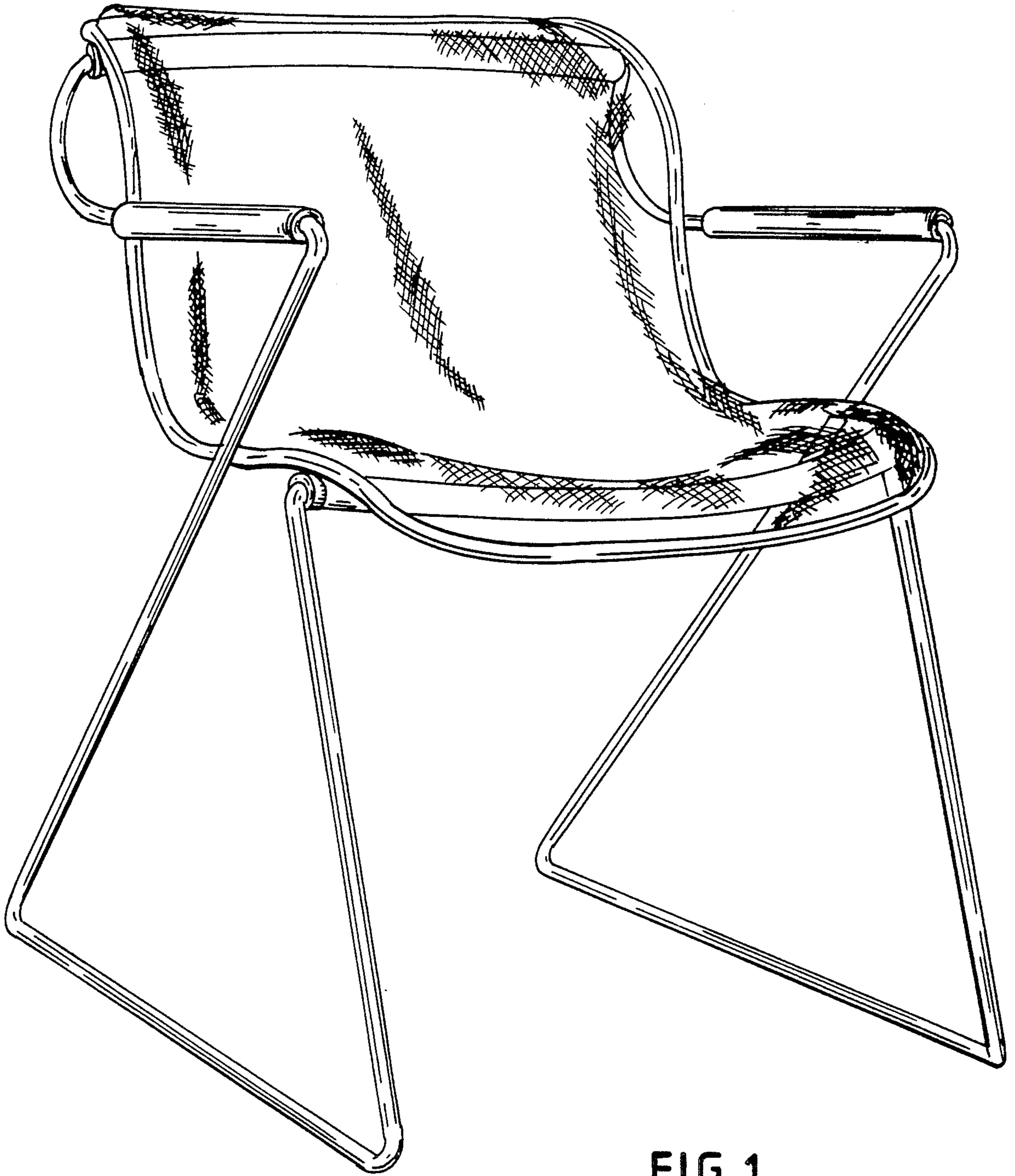
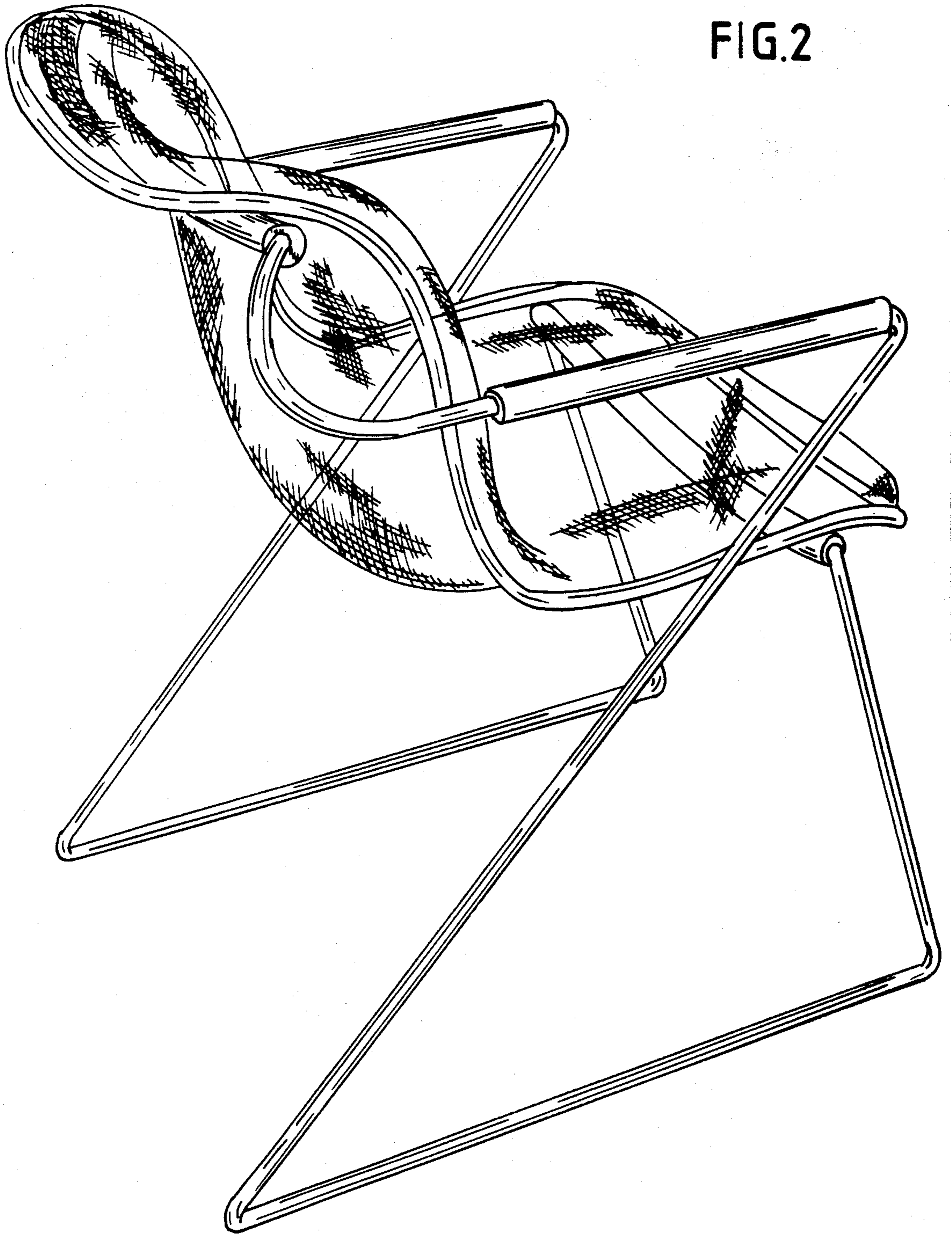

FIG. 1

FIG.2



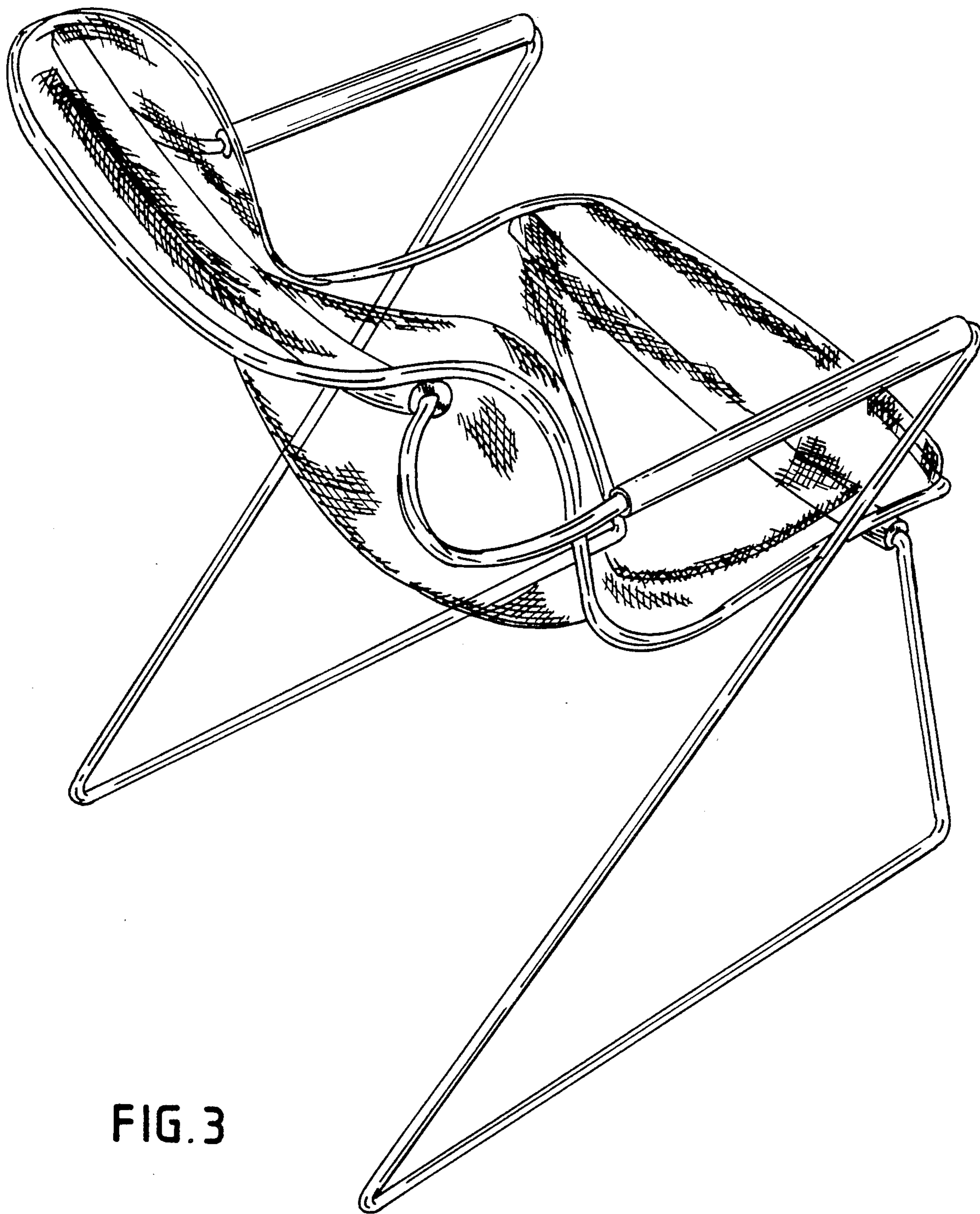

FIG. 3