

# United States Patent [19]

Breitschwerdt et al.

[11] Patent Number: **Des. 278,992**

[45] Date of Patent: **\*\* May 28, 1985**

[54] **AUTOMOBILE**

[75] Inventors: **Werner Breitschwerdt, Stuttgart;**  
**Friedrich van Winsen, Kirchheim;**  
**Bruno Sacco, Sindelfingen, all of**  
**Fed. Rep. of Germany**

[73] Assignee: **Daimler-Benz Aktiengesellschaft,**  
**Fed. Rep. of Germany**

[\*\*] Term: **14 Years**

[21] Appl. No.: **367,998**

[22] Filed: **Apr. 13, 1982**

[30] **Foreign Application Priority Data**

Oct. 15, 1981 [DE] Fed. Rep. of Germany ..... 5376  
[52] U.S. Cl. .... **D12/92**  
[58] Field of Search ..... **D12/91, 92; D21/136;**  
**296/185**

[56] **References Cited**

**U.S. PATENT DOCUMENTS**

D. 235,860 7/1975 Wilfert et al. .... D12/92

**OTHER PUBLICATIONS**

Motor Trend, 11/79, p. 59, Mercedes Benz S-Car.  
280SL, 350SL, 450SL Catalog, ©7/77, p. 28, 450SL  
Vehicle, lower center of page.

*Primary Examiner*—James M. Gandy  
*Attorney, Agent, or Firm*—Craig and Burns

[57] **CLAIM**

The ornamental design for an automobile, as shown and described.

**DESCRIPTION**

FIG. 1 is a front perspective view of an automobile showing our new design;  
FIG. 2 is a rear perspective view thereof;  
FIG. 3 is a side perspective view thereof;  
FIG. 4 is a side perspective view thereof opposite that shown in FIG. 3;  
FIG. 5 is a front elevational view thereof;  
FIG. 6 is a rear elevational view thereof; and  
FIG. 7 is a top perspective view thereof.

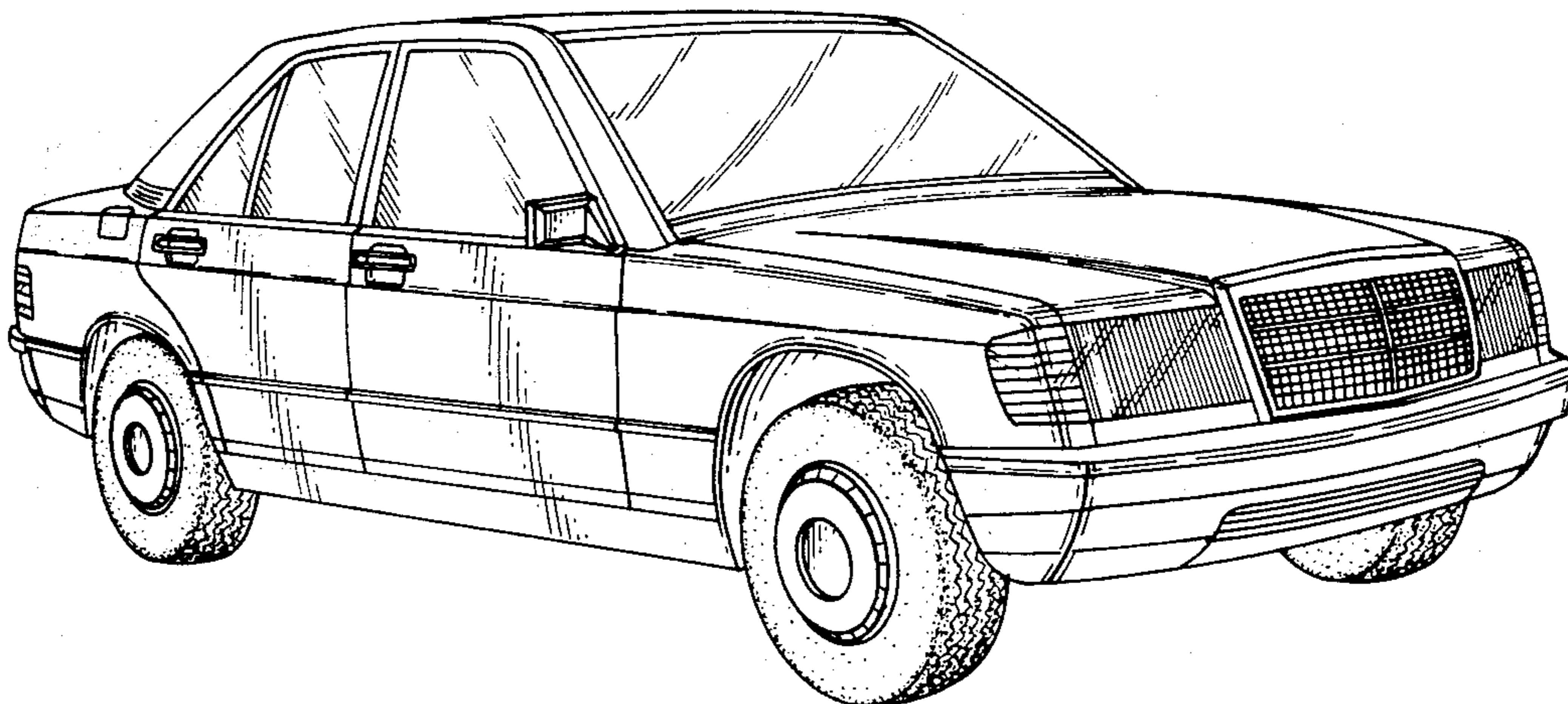

FIG. 1.

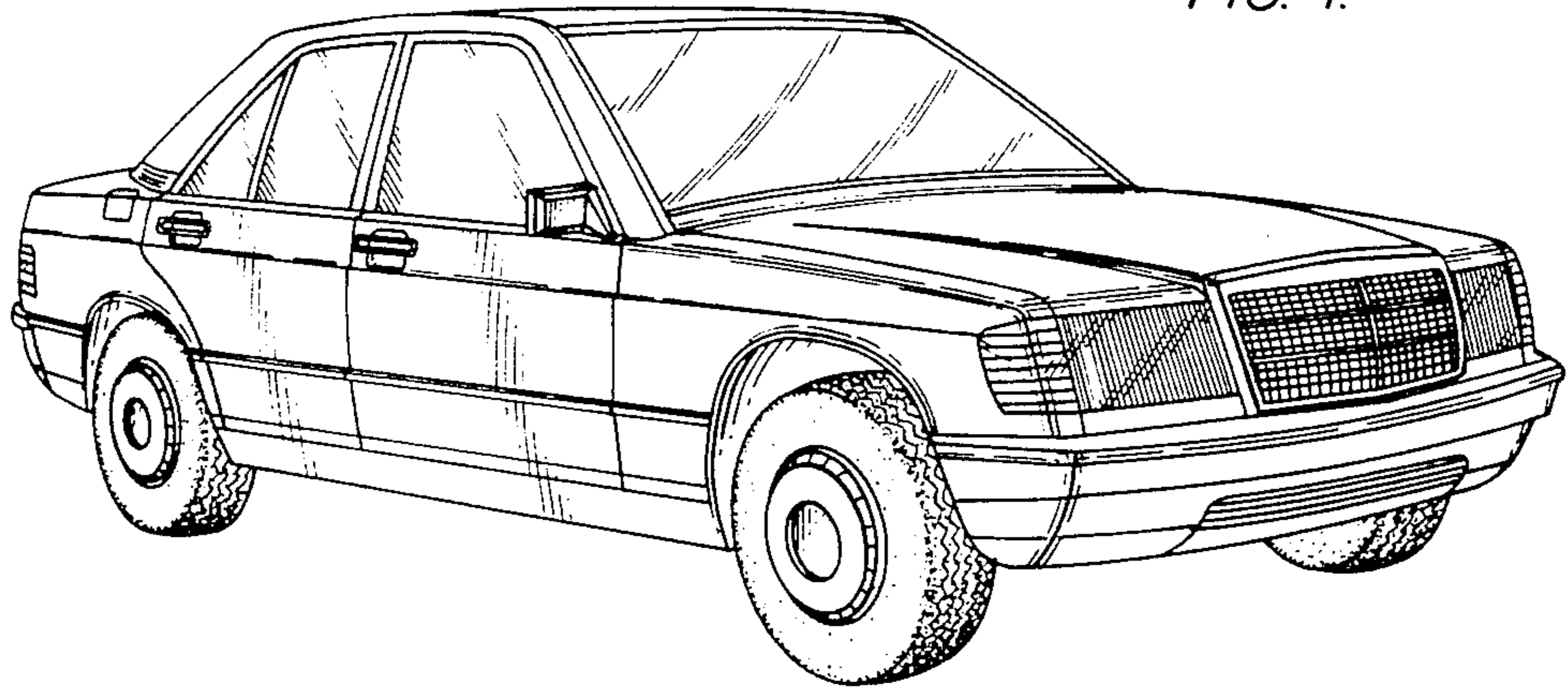
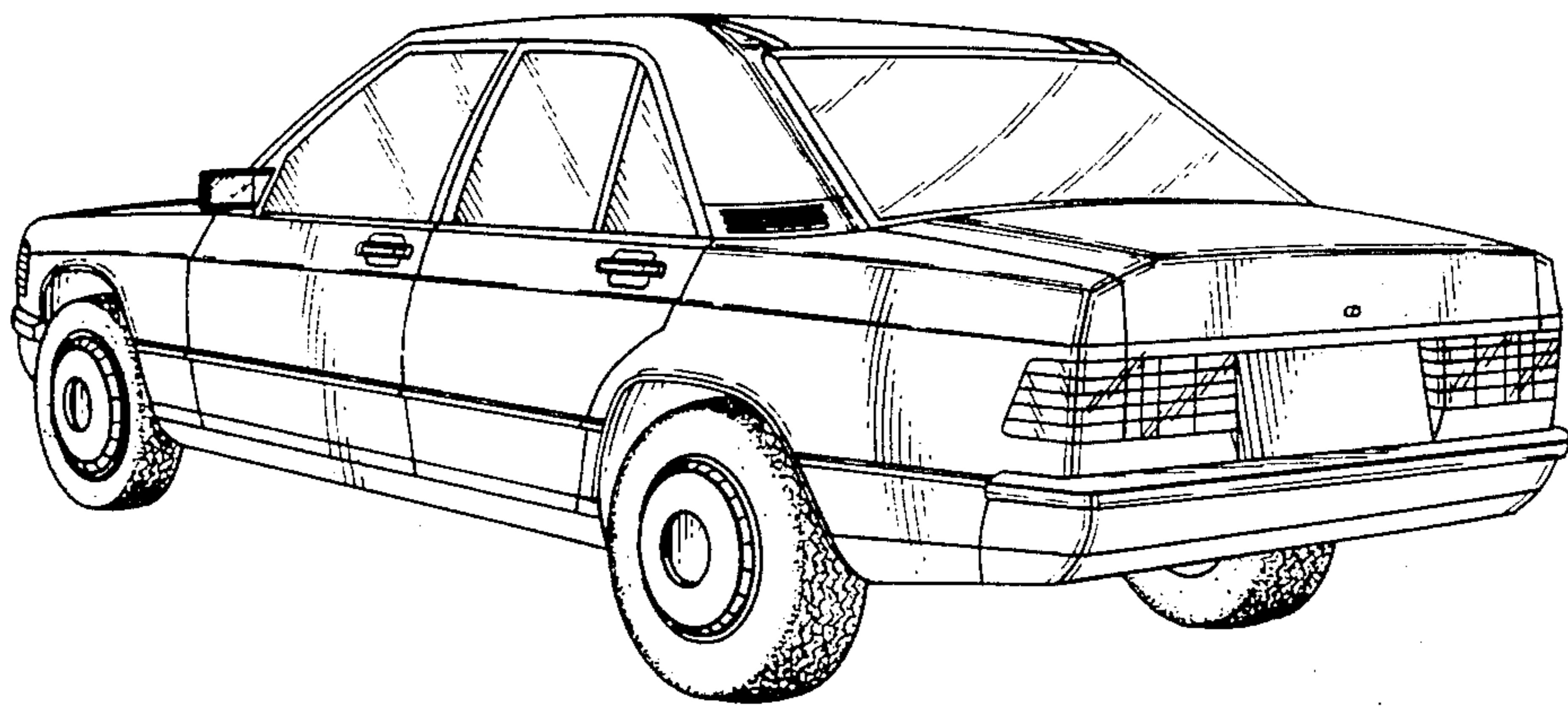

FIG. 2.



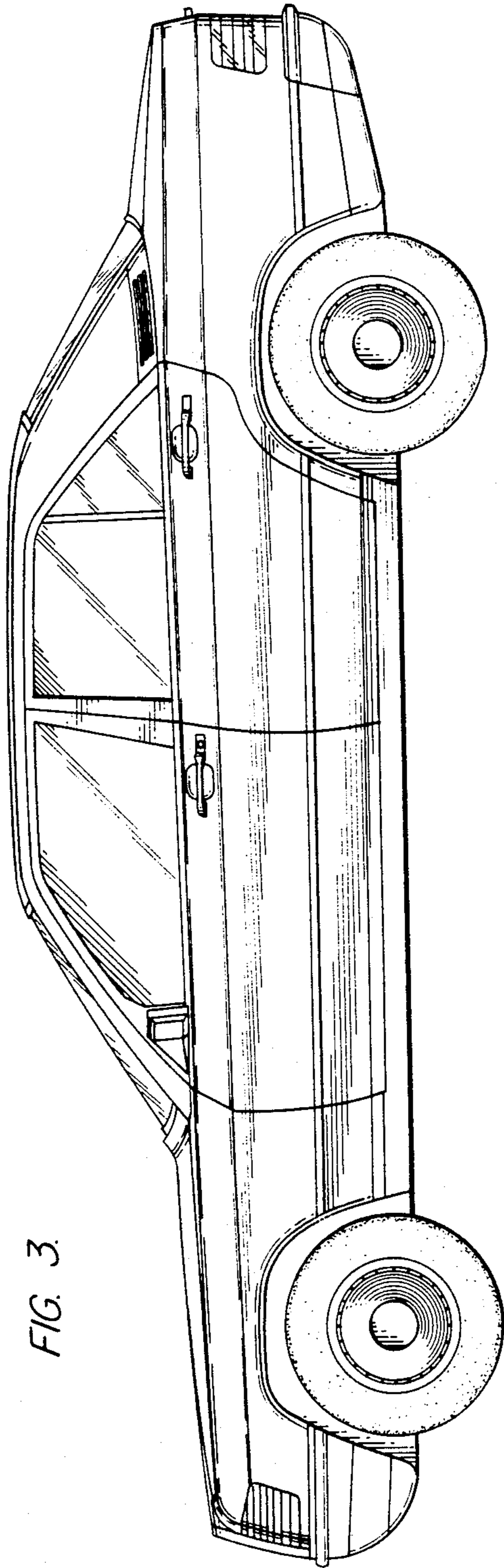

FIG. 3.

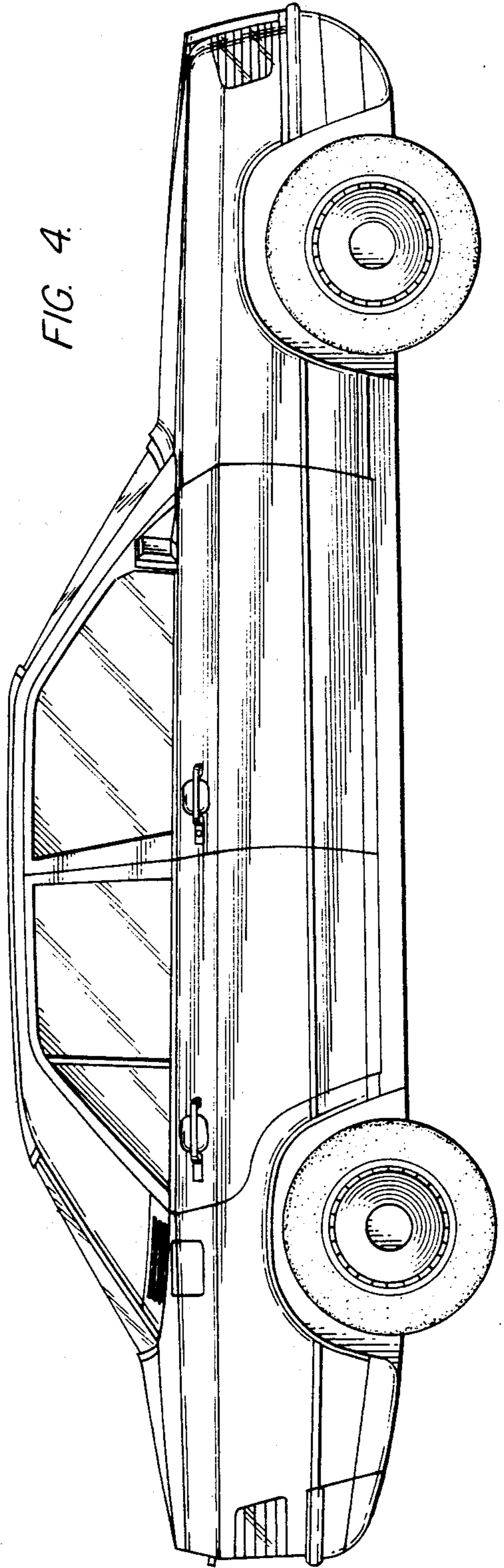

FIG. 4.

FIG. 5.

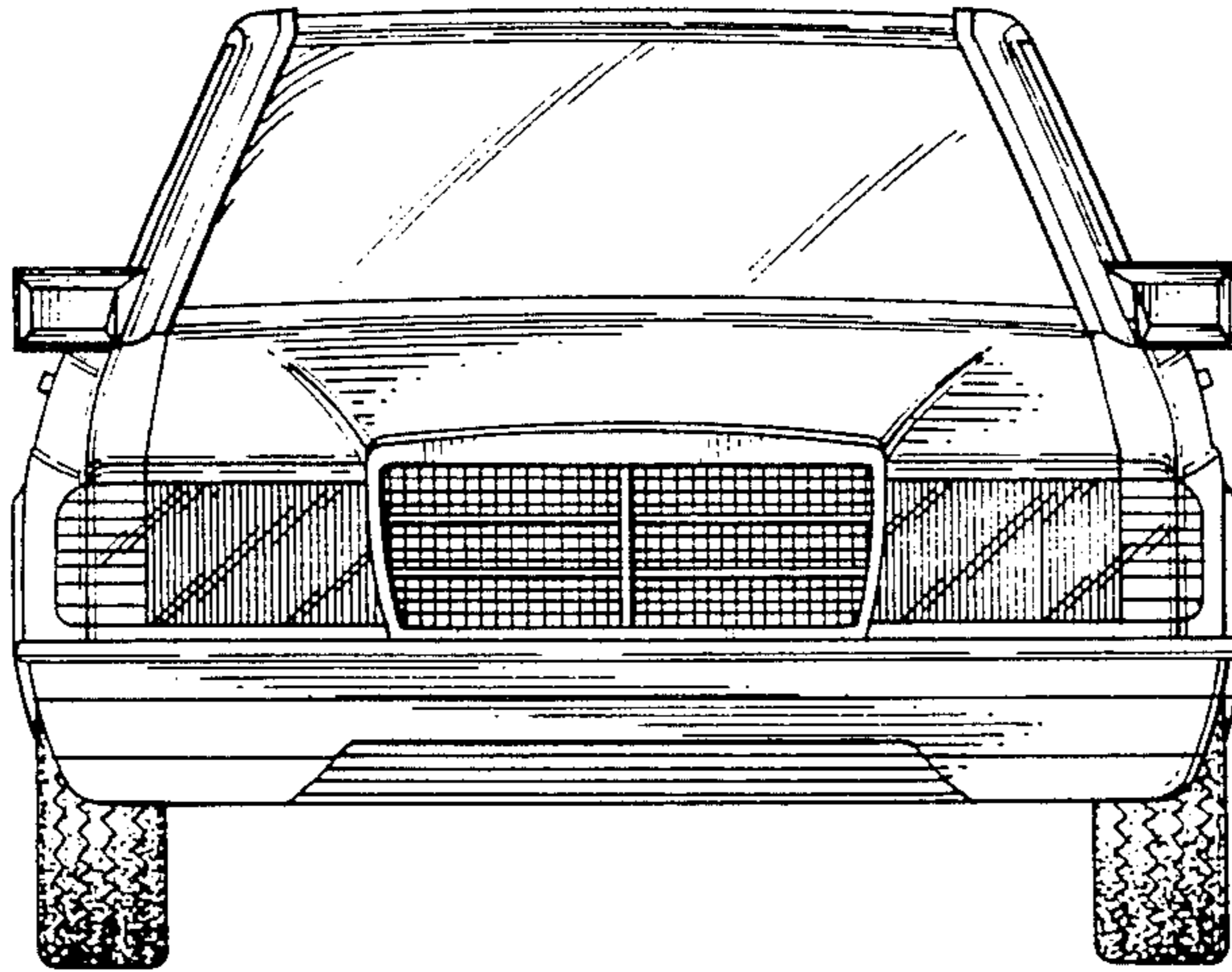

FIG. 6.

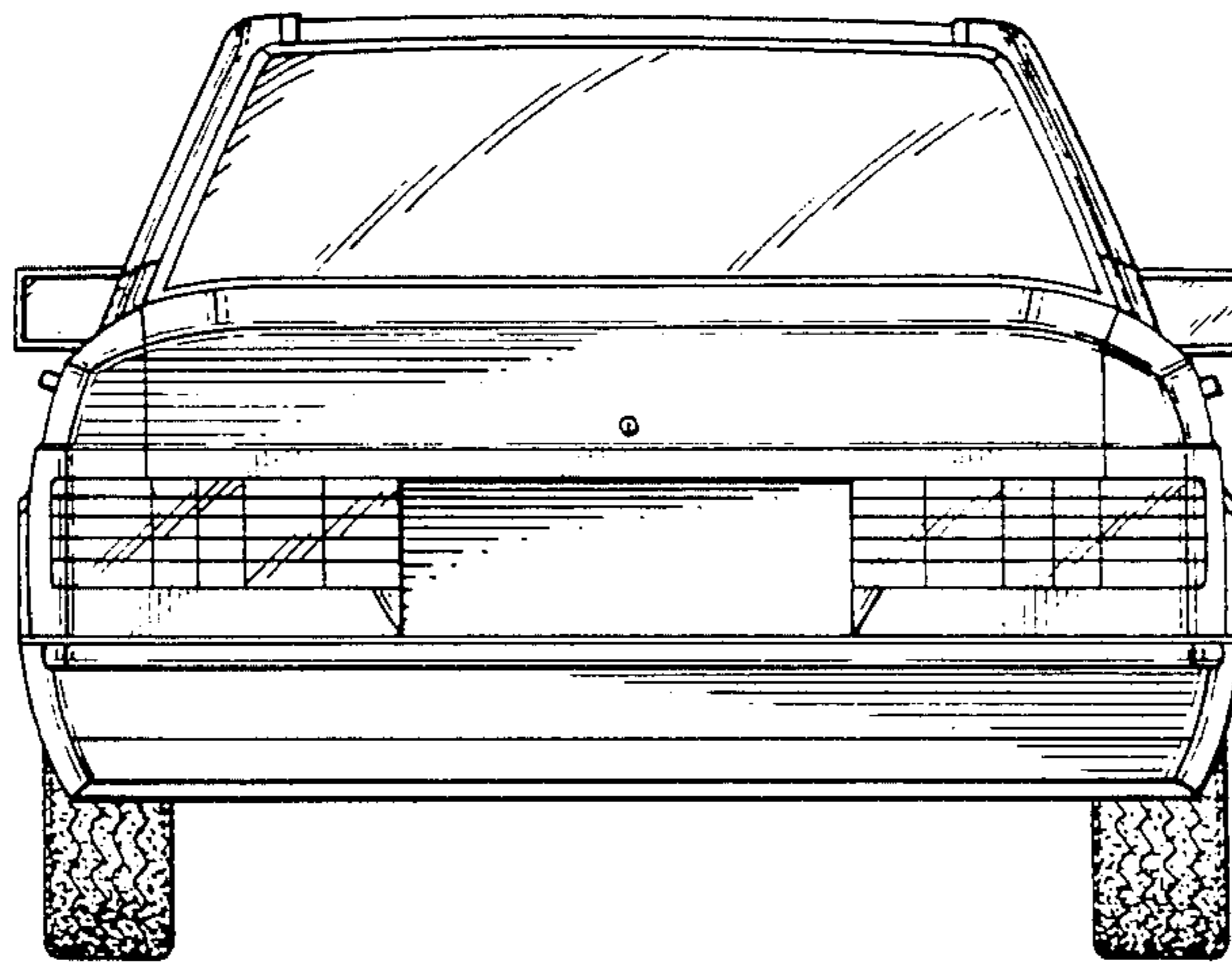

FIG. 7

