

[54] CONTROL FOR A VIDEO GAME OR THE LIKE

[75] Inventor: Syng N. Kim, Hoffman Estates, Ill.

[73] Assignee: Wico Corporation, Niles, Ill.

[\*\*] Term: 14 Years

[21] Appl. No.: 456,259

[22] Filed: Jan. 6, 1983

[52] U.S. Cl. .... D21/48

[58] Field of Search ..... D21/48, 13, 1; D13/11, D13/12, 32, 37, 38; 273/DIG. 28, 148 B, 1 GC, 85 G; D7/99, 102

[56] References Cited

U.S. PATENT DOCUMENTS

- D. 216,777 3/1970 Nelson ..... D9/371
- D. 269,609 7/1983 Kim ..... D13/38

- D. 271,220 11/1983 Fox et al. .... D21/48
- D. 271,313 11/1983 Nishi ..... D21/48

Primary Examiner—Melvin B. Feifer  
Attorney, Agent, or Firm—Emrich & Dithmar

[57] CLAIM

The ornamental design for a control for a video game or the like, as shown.

DESCRIPTION

FIG. 1 is a perspective view of a control for a video game or the like showing my new design; FIG. 2 is a top plan view thereof; FIG. 3 is a front elevational view thereof; FIG. 4 is a side elevational view thereof; FIG. 5 is a rear elevational view thereof; FIG. 6 is an elevational view of the side opposite FIG. 4; and FIG. 7 is a bottom plan view.

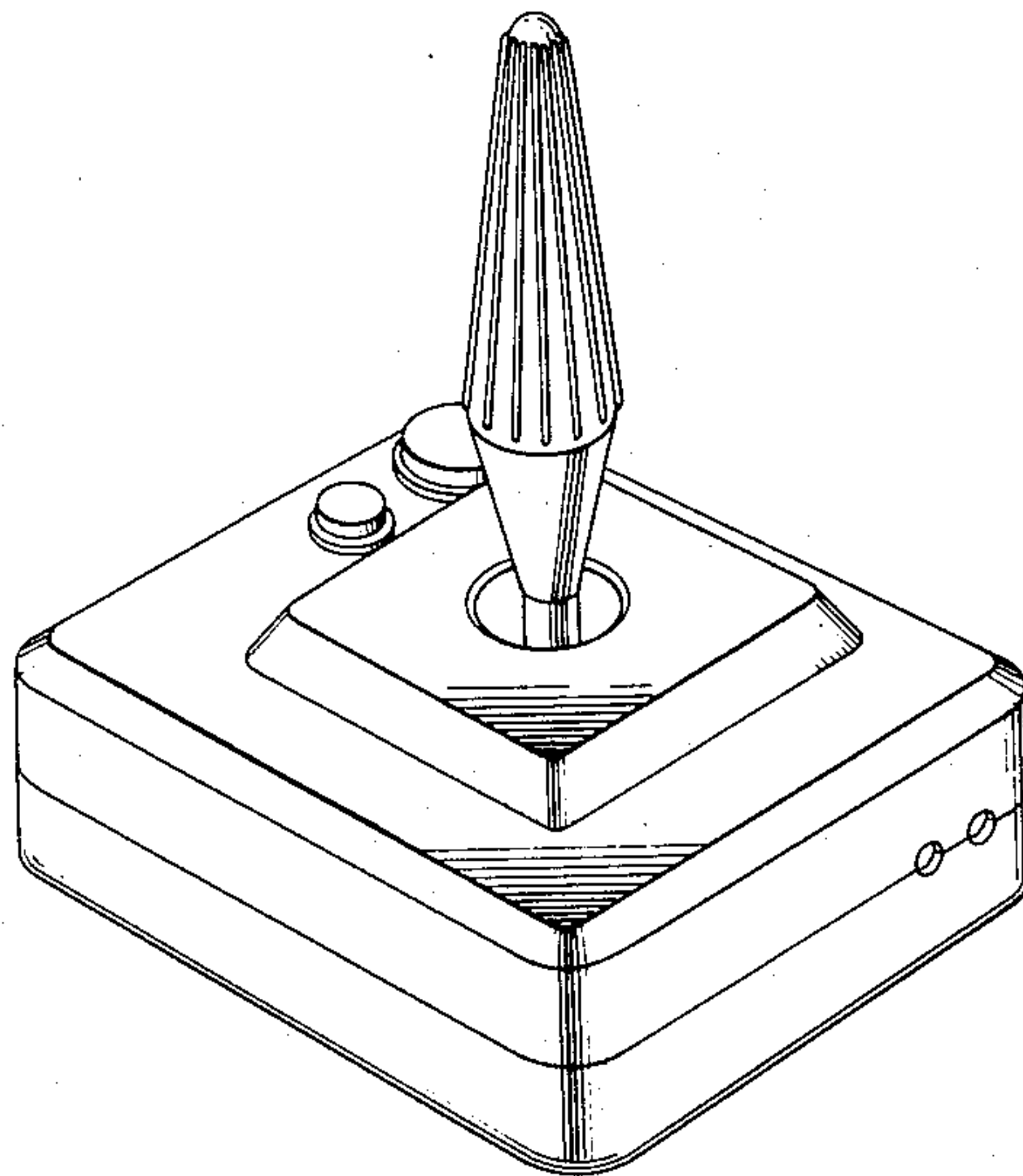

**FIG. 1**

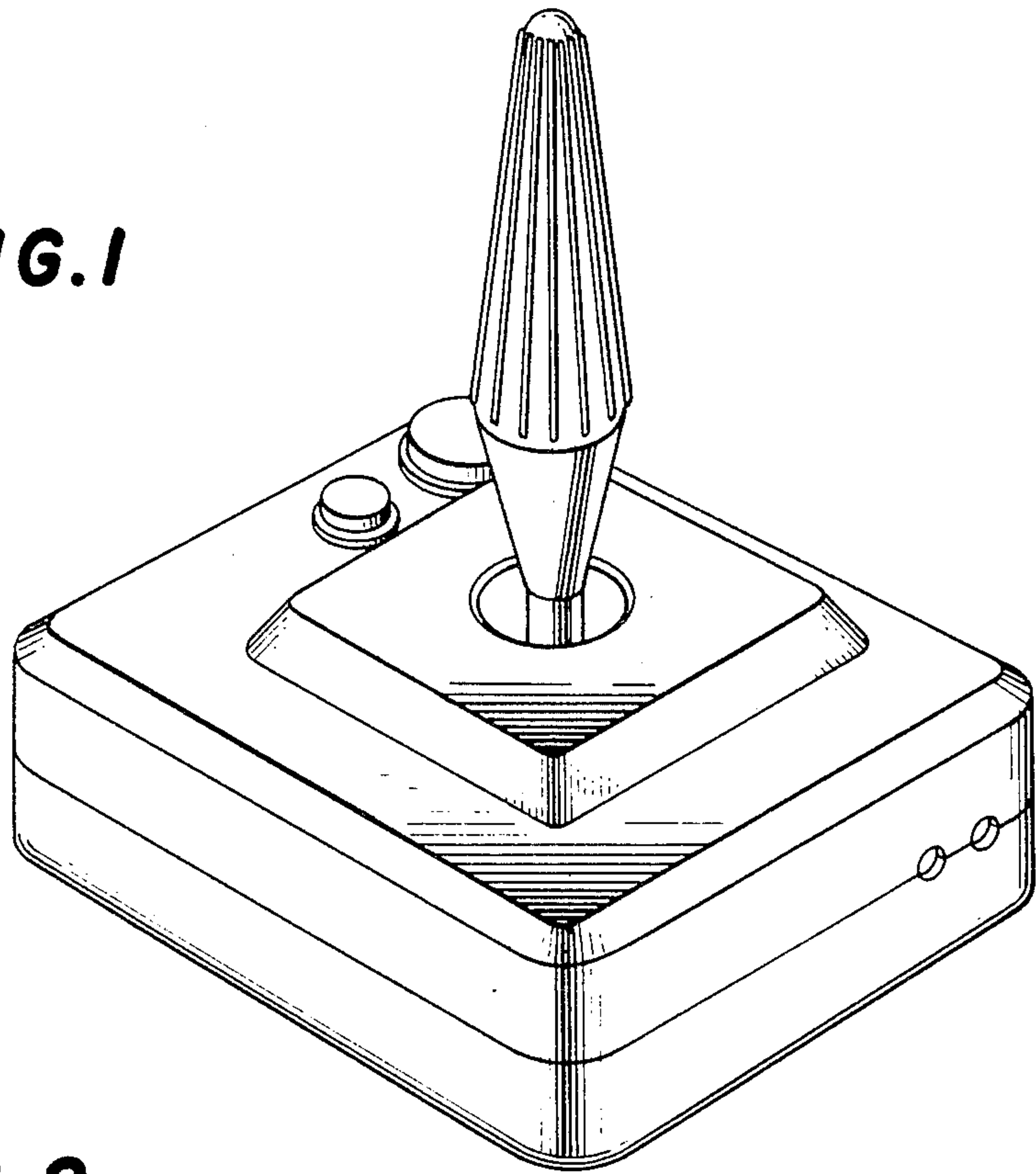

**FIG. 2**

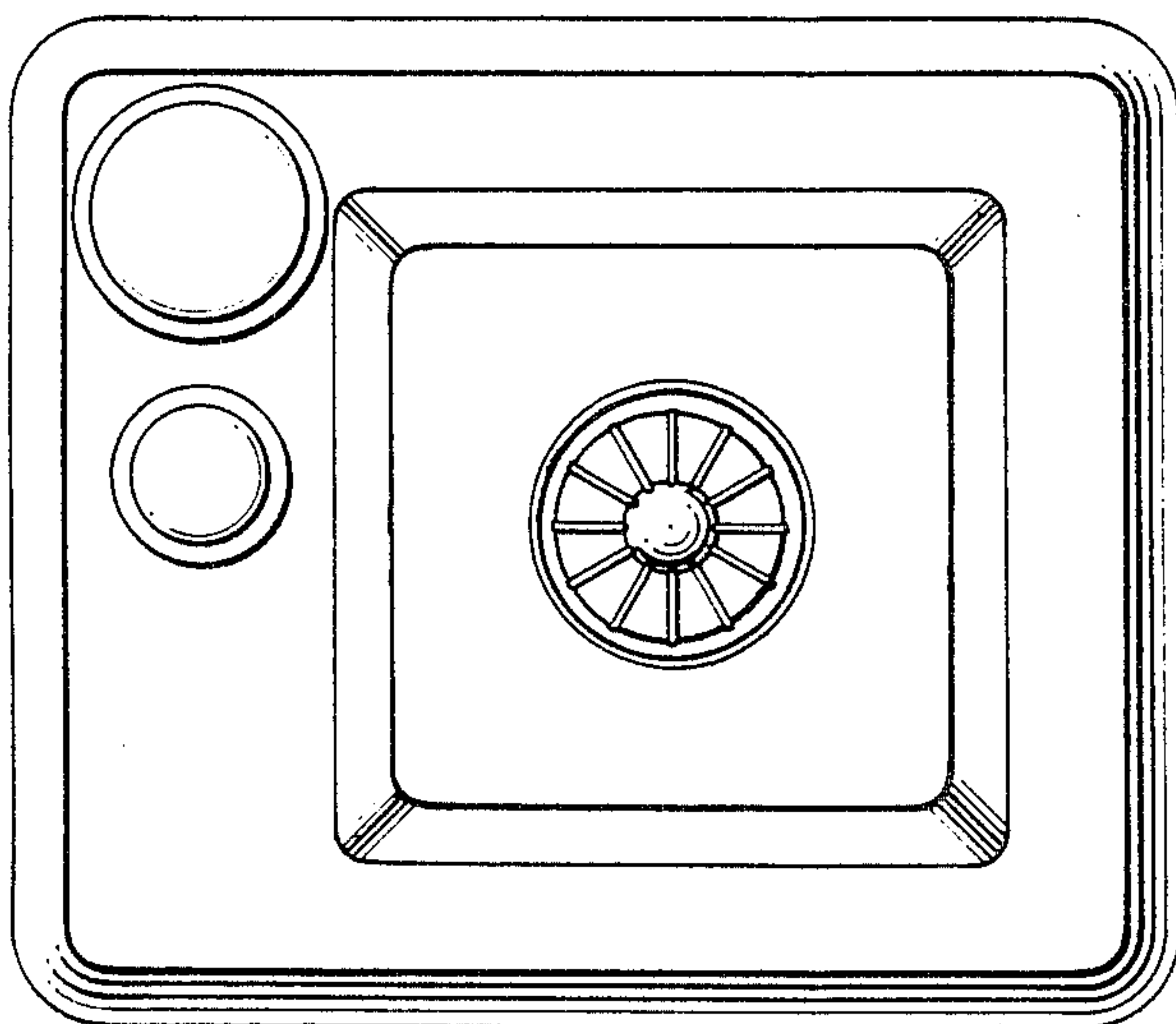

**FIG. 3**

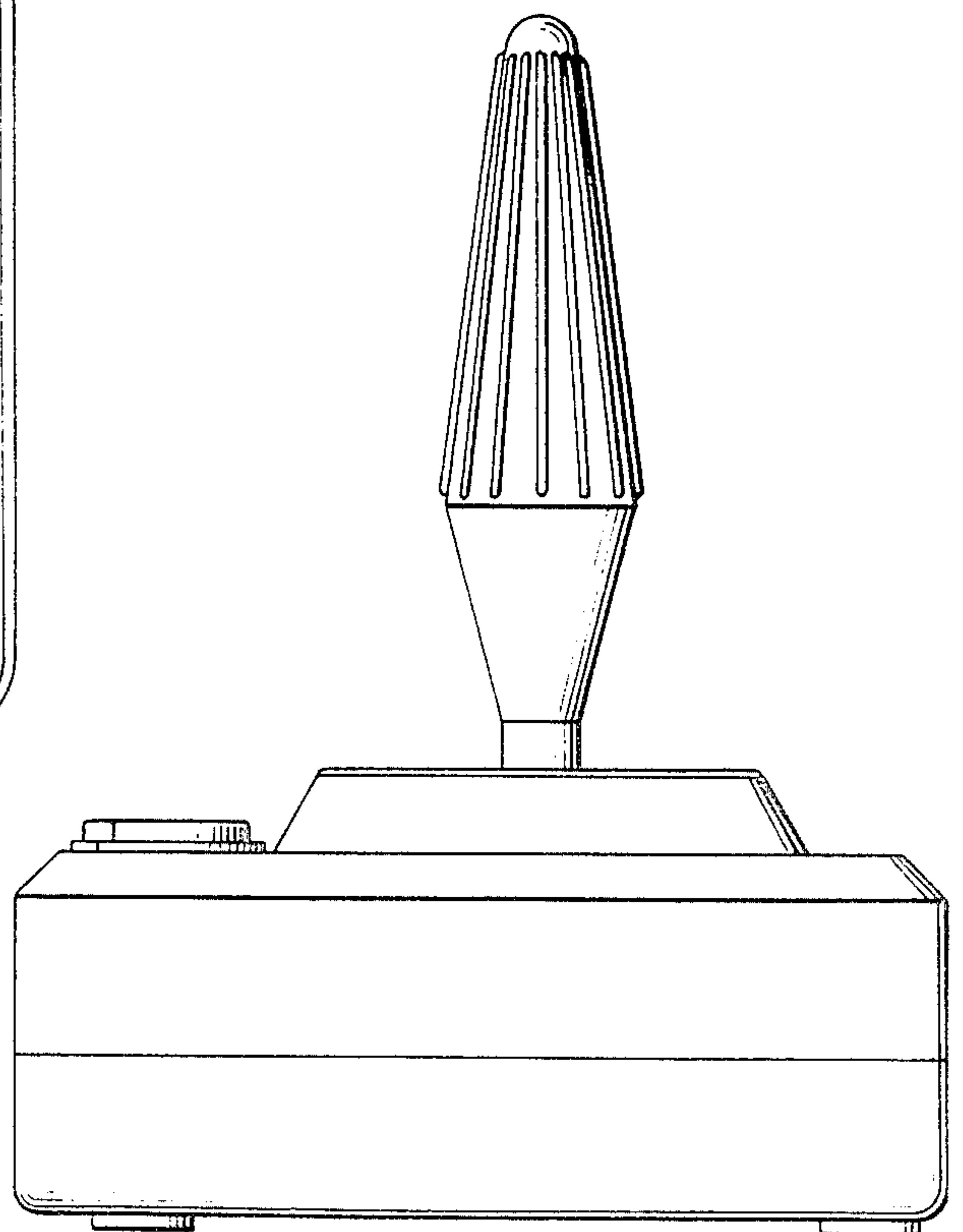

**FIG. 4**

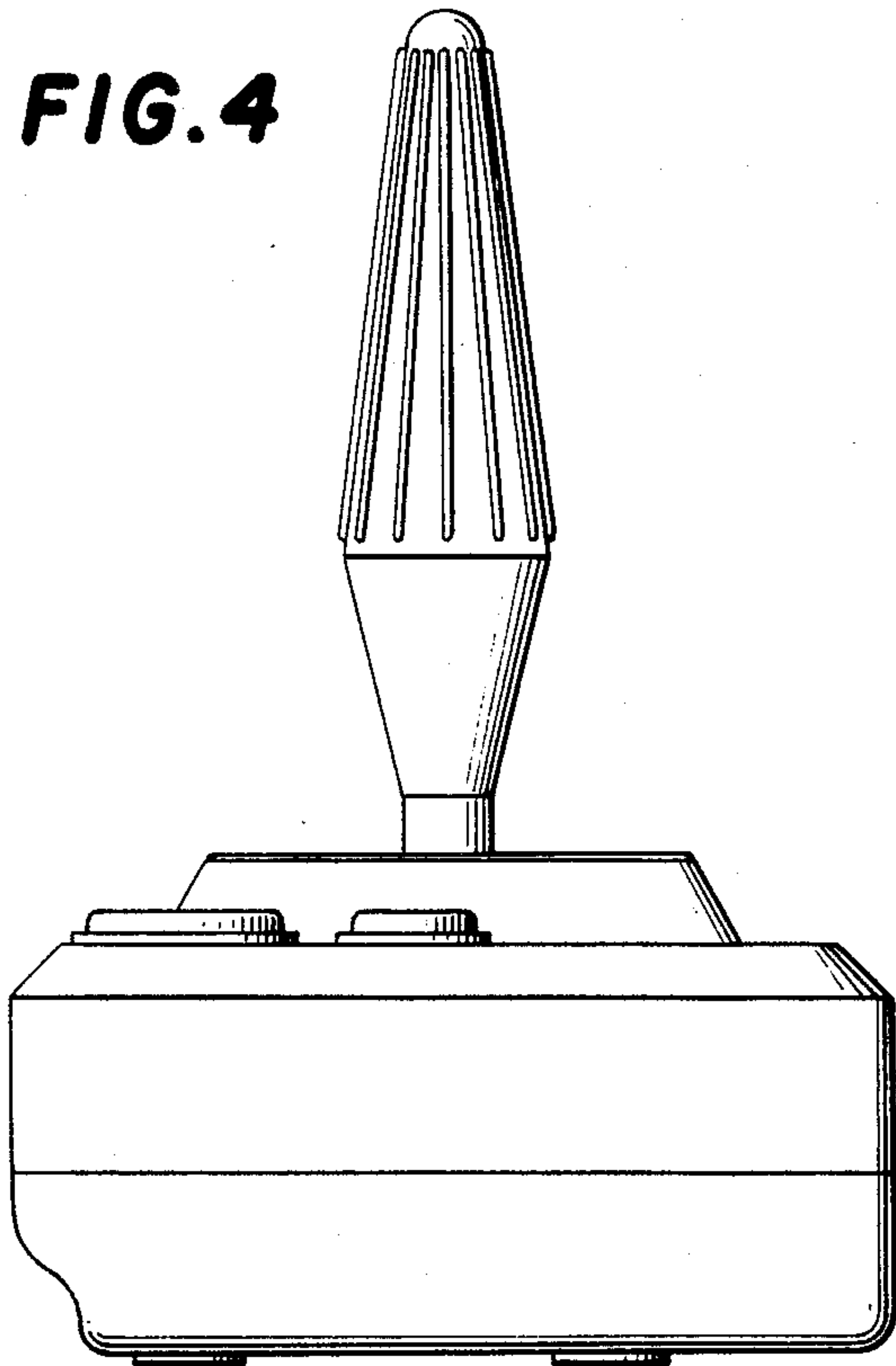

**FIG. 5**

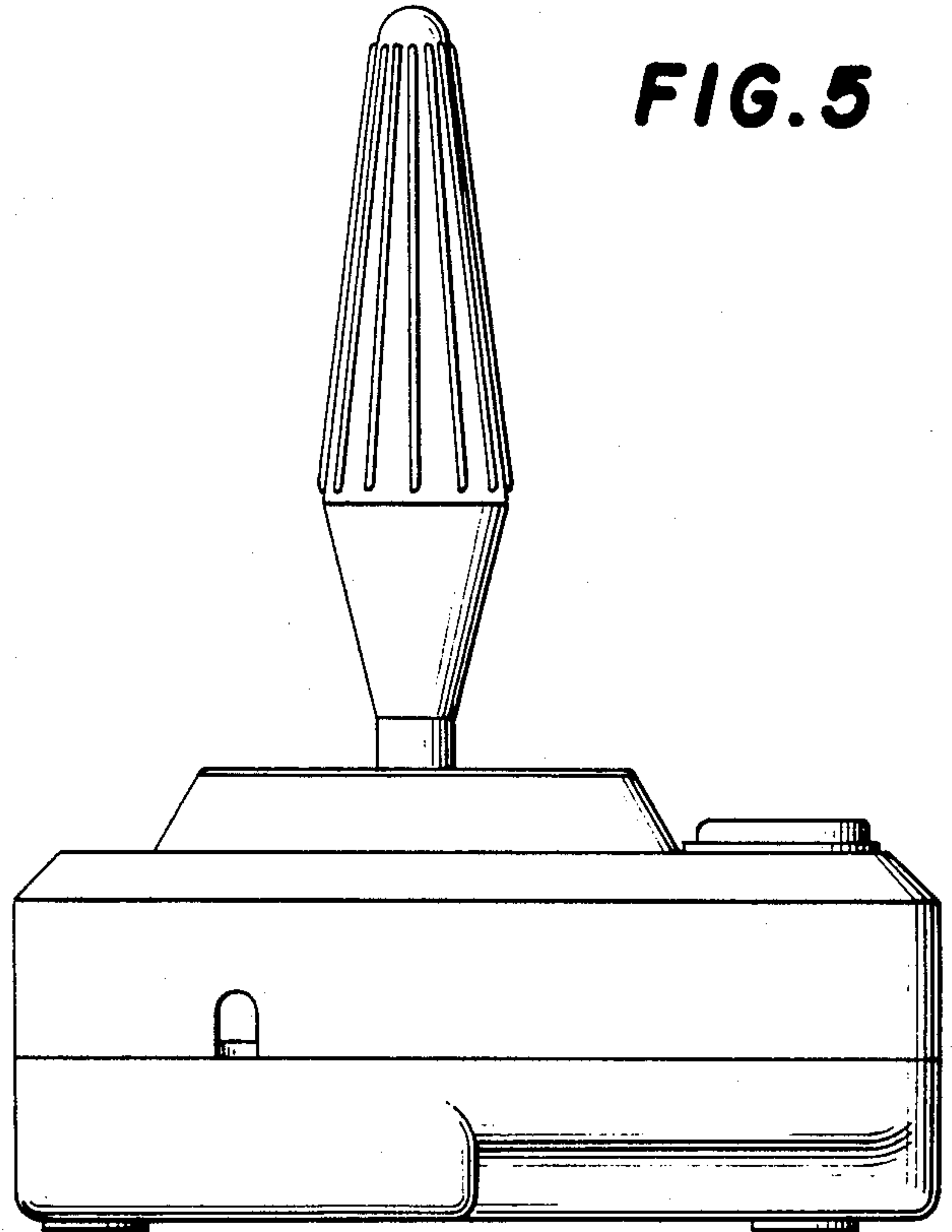

**FIG. 6**

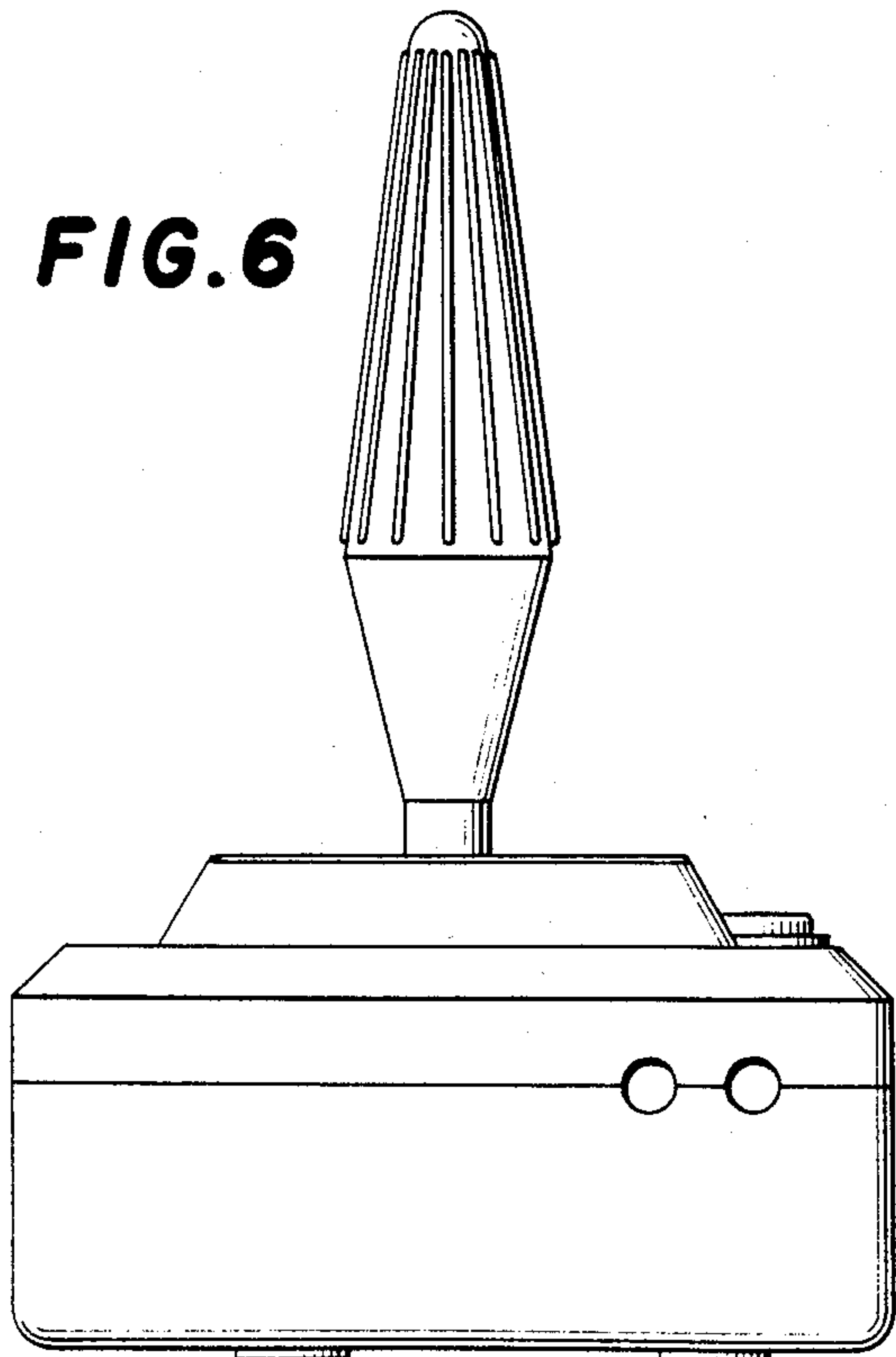

**FIG. 7**

