

[54] **TOY AIRPLANE**

[76] **Inventor:** Yasuaki Ninomiya, Suite 5-101
Tamaplaza, 20 Utsukushigaoka,
1-chome, Midoriku, Yokohama,
Kanagawa, Japan

[**] **Term:** 14 Years

[21] **Appl. No.:** 441,649

[22] **Filed:** Nov. 15, 1982

[30] **Foreign Application Priority Data**

May 31, 1982 [JP] Japan 57-23960

[52] **U.S. Cl.** D21/89

[58] **Field of Search** D21/87, 88, 89, 90,
D21/82; 244/93, 153 R, 154, 155 R; 446/61, 62,
63, 64, 65, 66, 67, 68

[56] **References Cited**

U.S. PATENT DOCUMENTS

- D. 242,866 12/1976 Ditto D21/87
- D. 257,997 1/1981 Hoeft D21/89
- 1,035,017 8/1912 Kaiser et al. D21/90

- 2,599,957 6/1952 Walker 244/93
- 2,664,666 1/1954 Walker 446/61

OTHER PUBLICATIONS

"Go Fly a Kite" Flier, 2-18-1980, p. 15, #815, Galactical Gliders.

Primary Examiner—Charles A. Rademaker
Attorney, Agent, or Firm—Spensley, Horn, Jubas & Lubitz

[57] **CLAIM**

The ornamental design for a toy airplane, as shown.

DESCRIPTION

FIG. 1 is a left side perspective view of a toy airplane showing my new design;
FIG. 2 is a bottom perspective view;
FIG. 3 is a front elevational view;
FIG. 4 is a rear elevational view;
FIG. 5 is a left side elevational view;
FIG. 6 is a right side elevational view;
FIG. 7 is a top plan view; and
FIG. 8 is a bottom plan view.

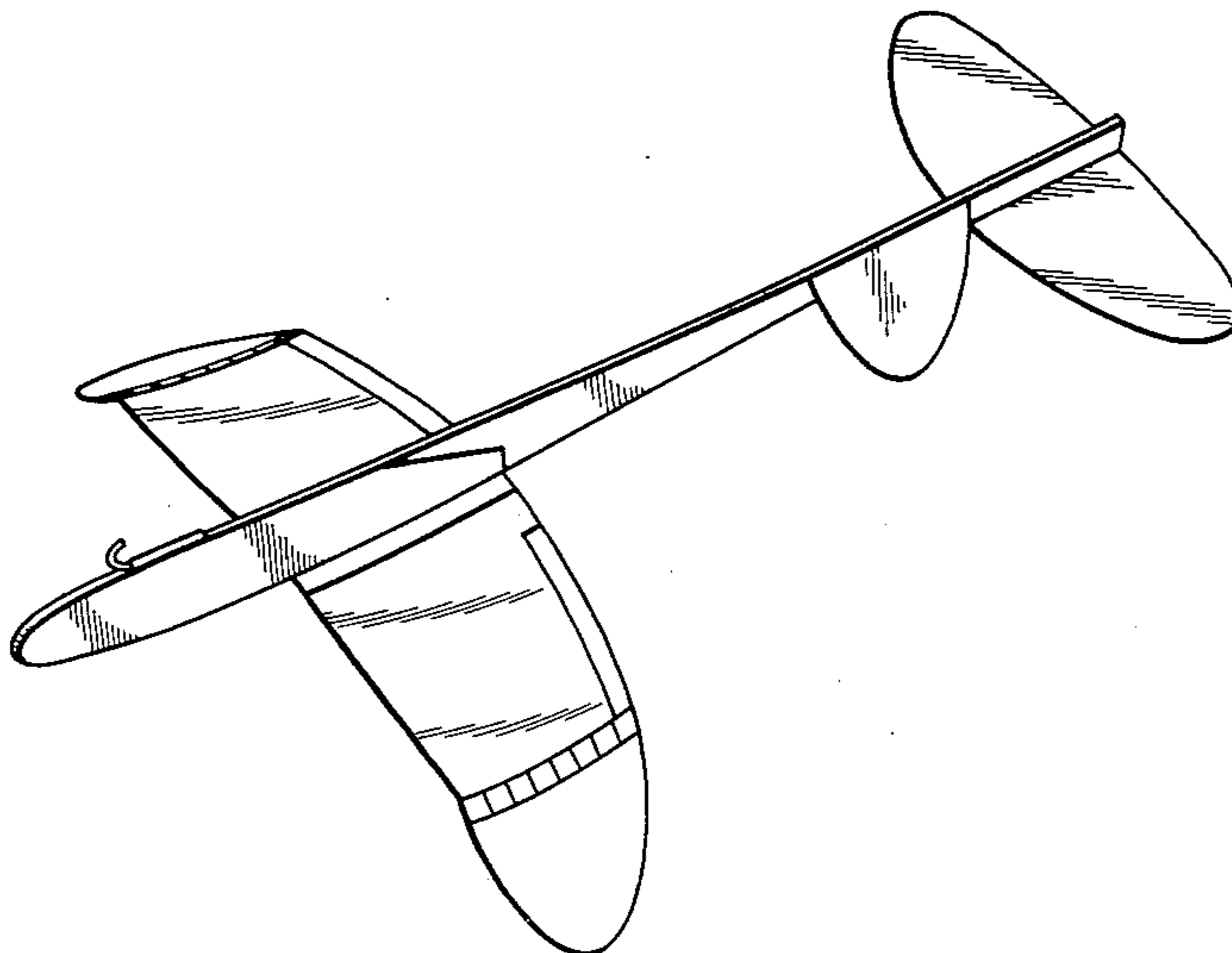

FIG. 1

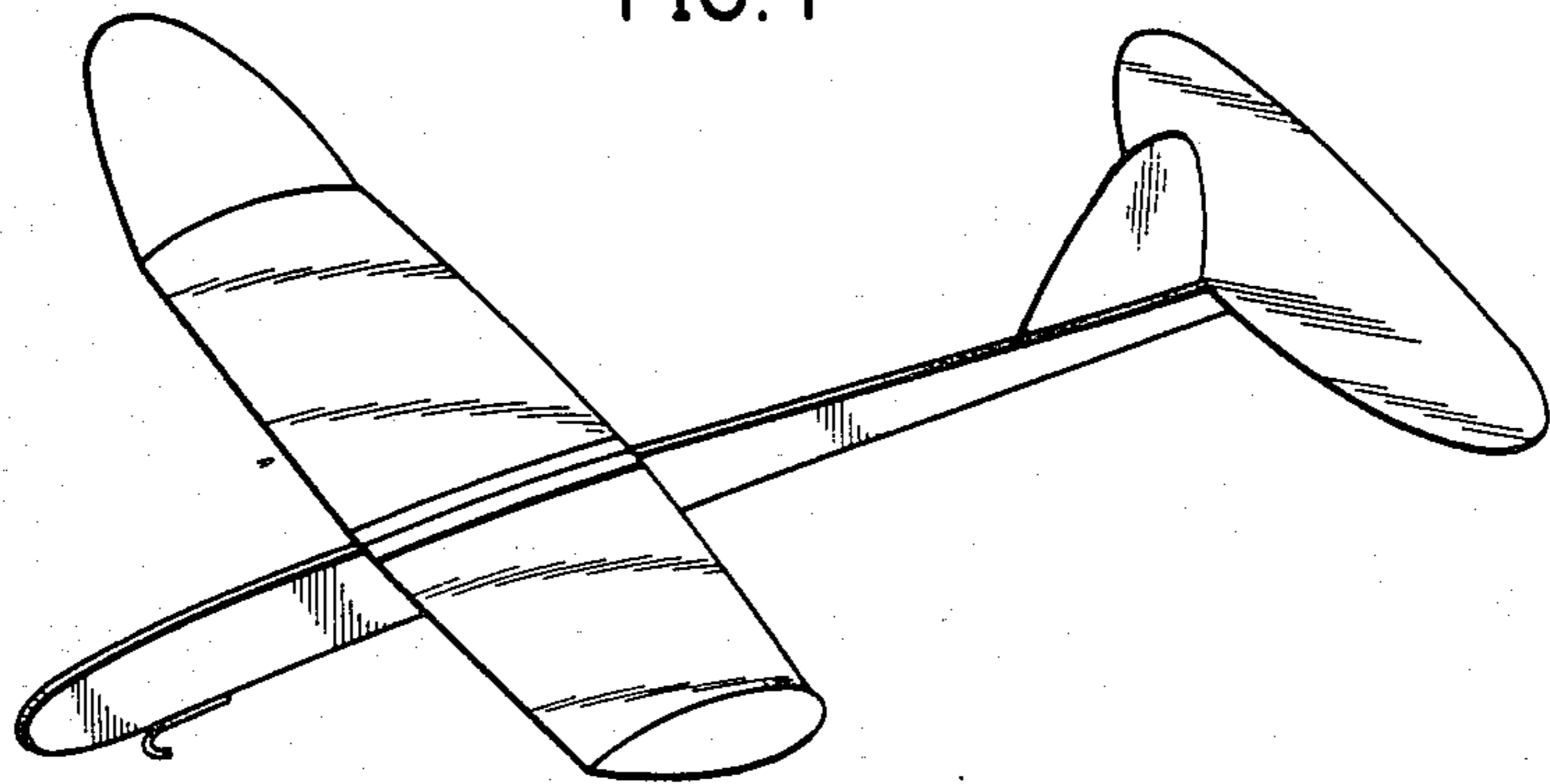

FIG. 2

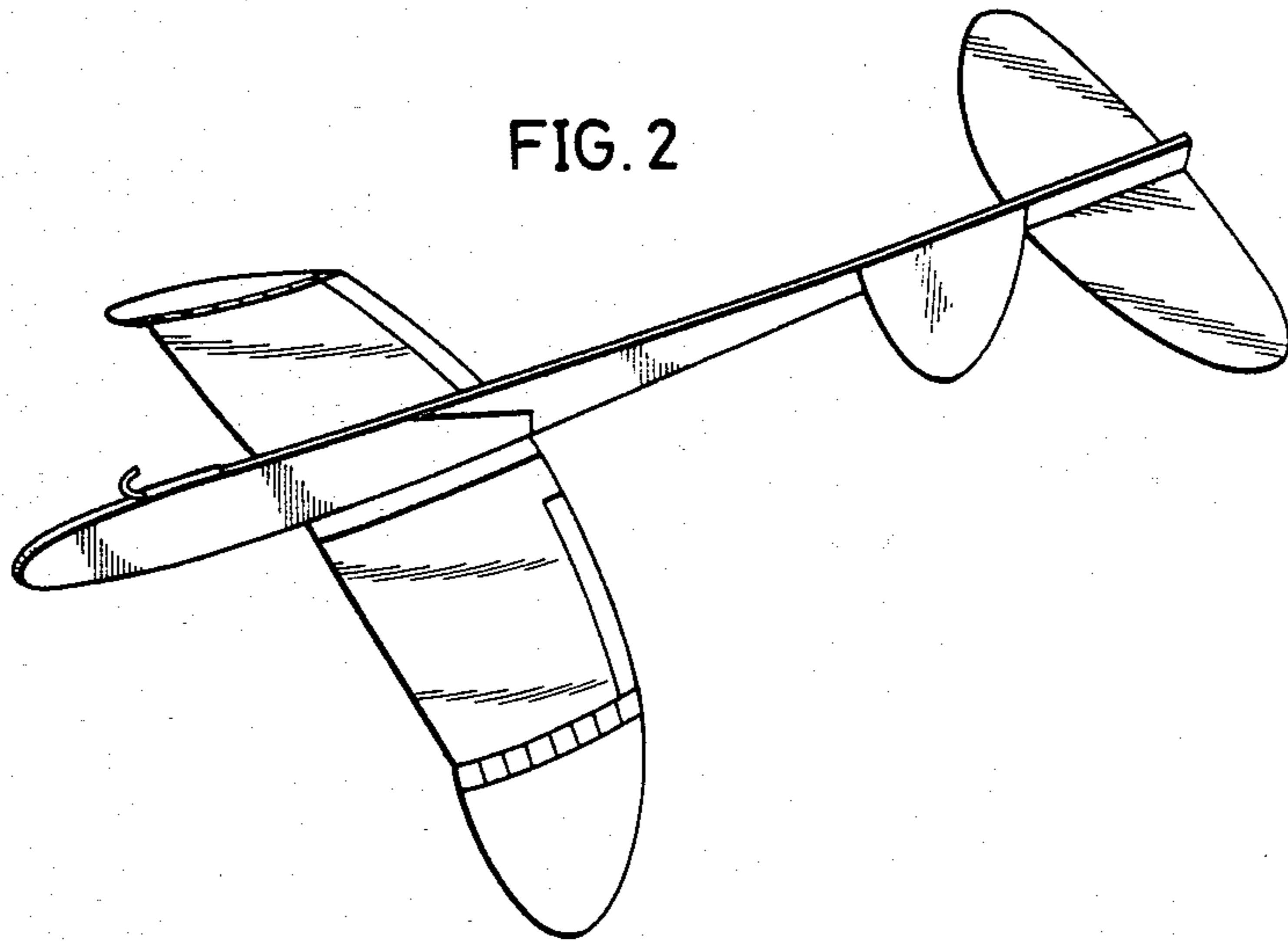

FIG. 3

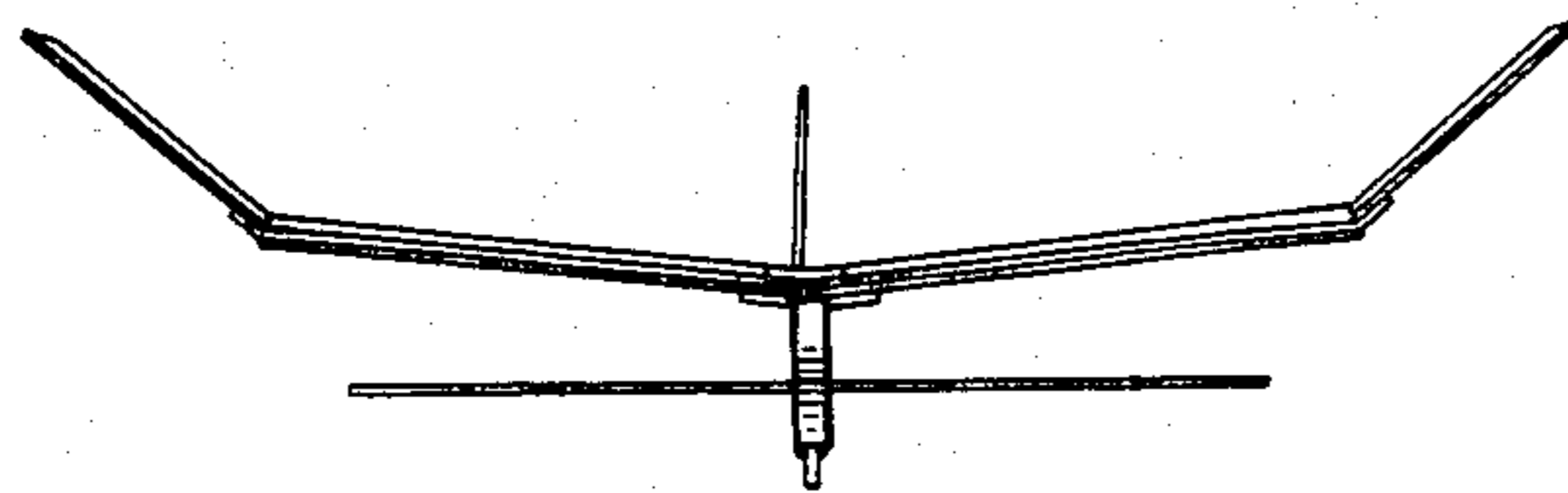

FIG. 4

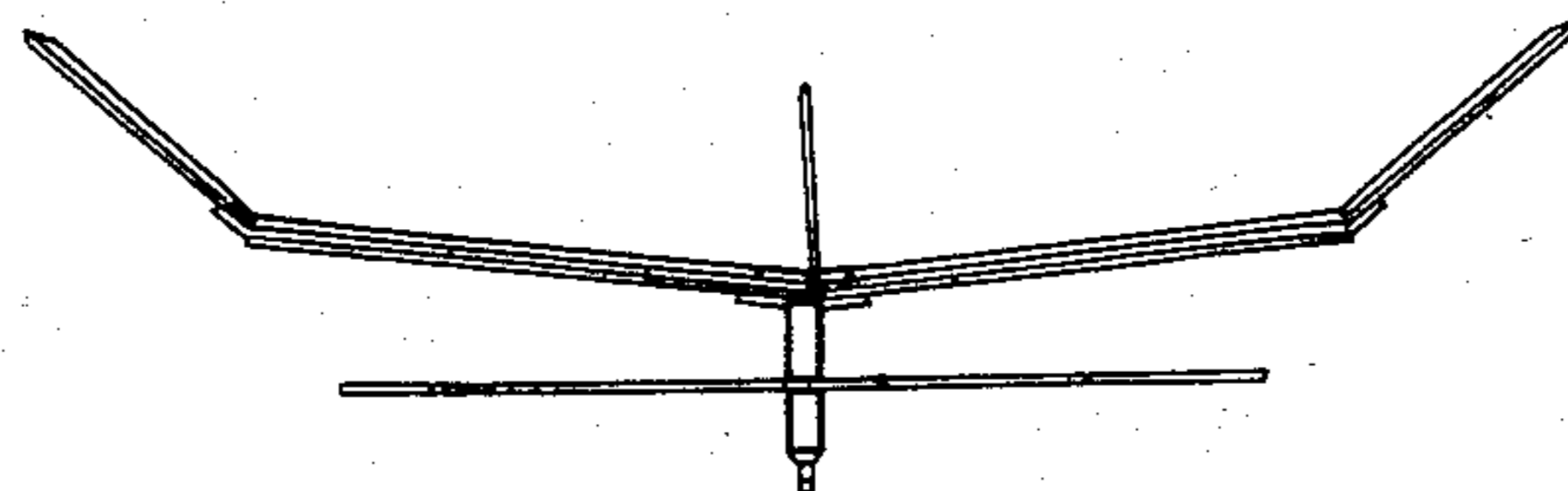

FIG. 5

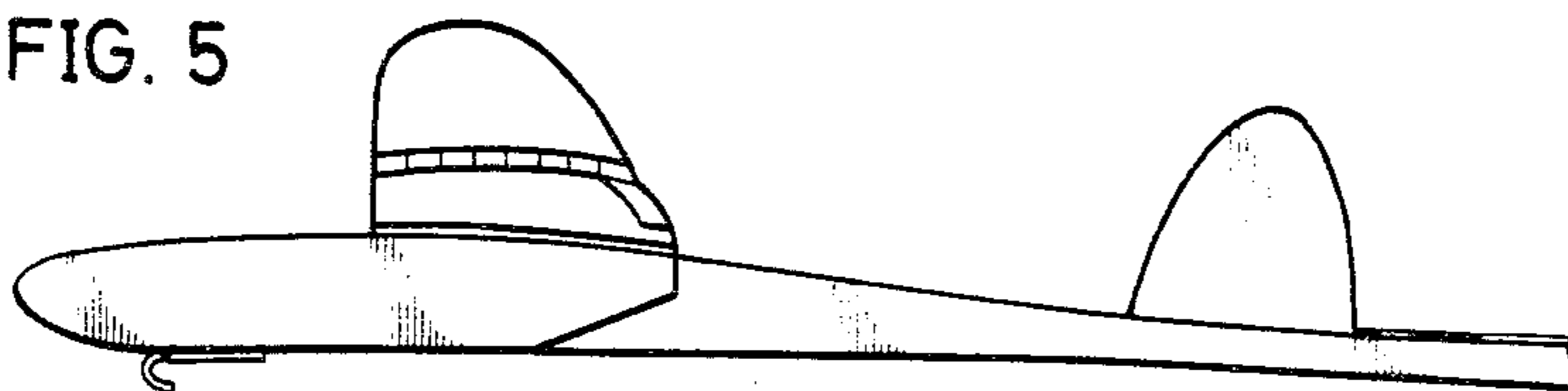

FIG. 6

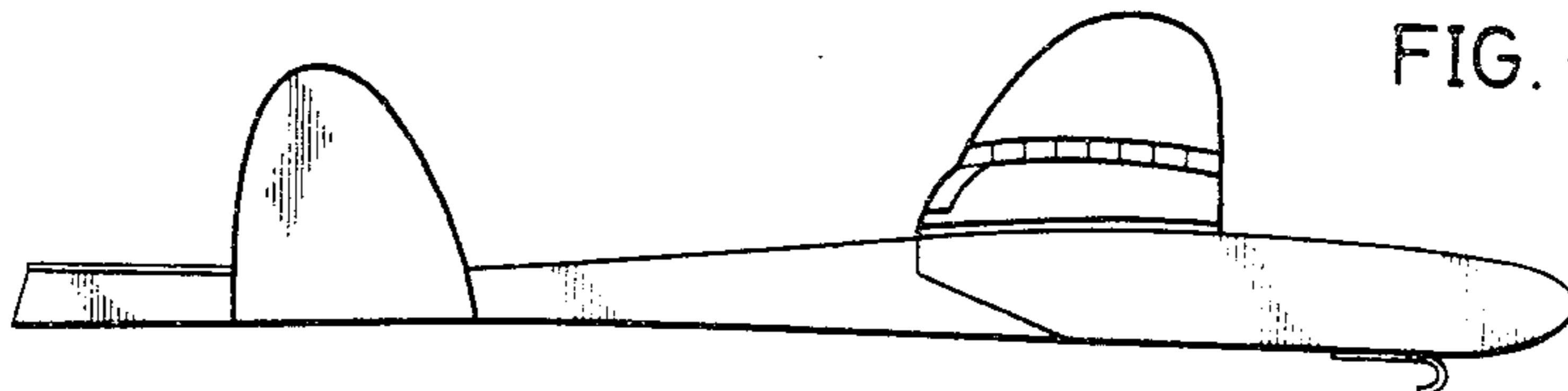

FIG. 7

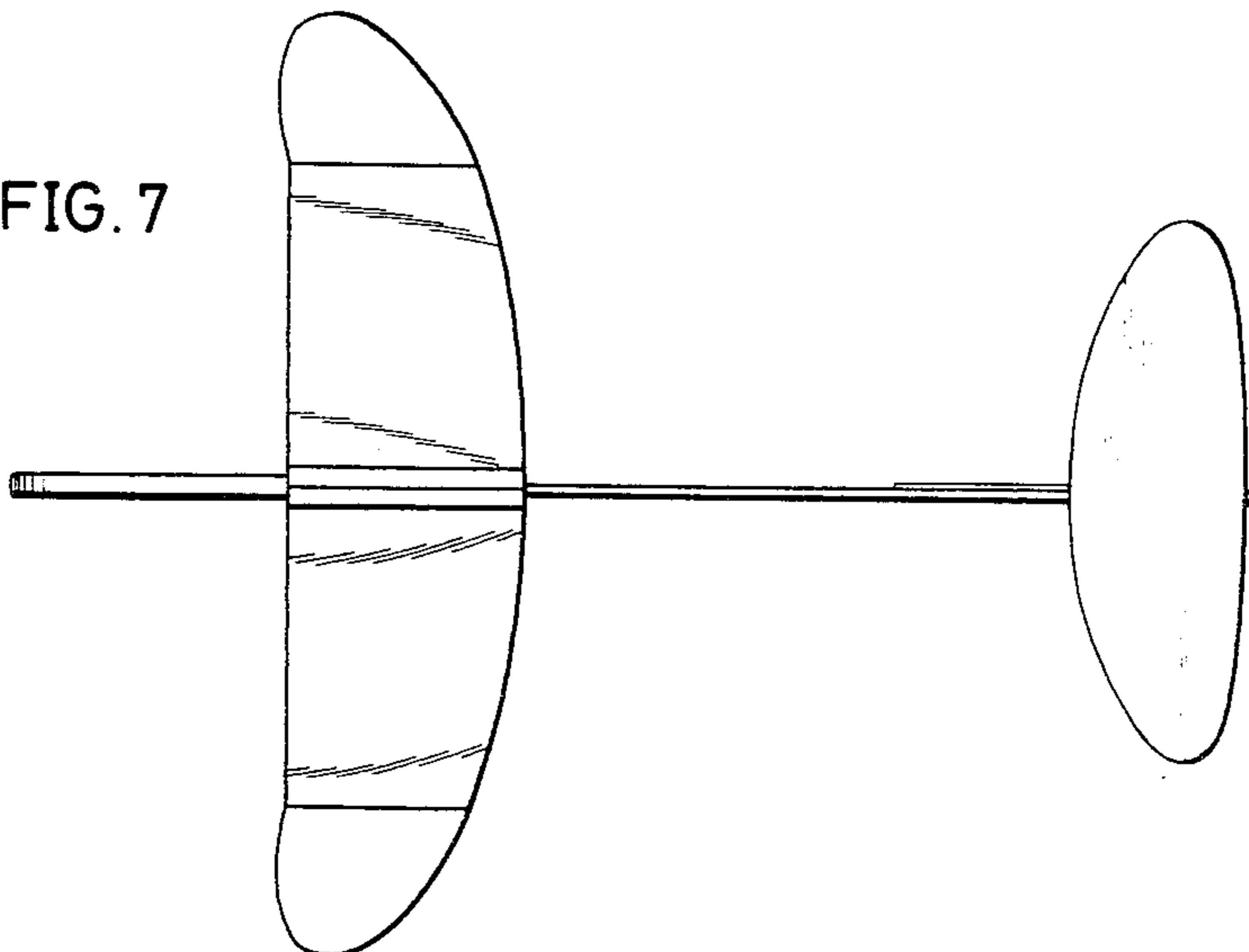

FIG. 8

