

[54] ELECTRICAL POWER MODULE

[75] Inventor: Davis P. Stone, Canyon Country, Calif.

[73] Assignee: Hopkins Engineering Company, Calif.

[**] Term: 14 Years

[21] Appl. No.: 509,216

[22] Filed: Jun. 29, 1983

[52] U.S. Cl. D13/24; D13/11; D13/35

[58] Field of Search D13/11, 12, 13, 24, D13/30, 35; 361/331, 332, 333, 334, 347, 346, 349, 357, 358, 380, 390; 174/52 R, 50

[56] References Cited

U.S. PATENT DOCUMENTS

- D. 64,594 5/1924 Hubbell .
- D. 206,589 1/1967 Goldbaum et al. D26/1
- D. 210,536 3/1968 Paganelli D26/13
- D. 216,887 3/1970 Kahn D13/3
- D. 222,356 10/1971 Inhelder et al. D26/1
- 1,620,814 3/1927 Getchell .
- 3,080,493 3/1963 Kleinman 310/68

- 3,154,722 10/1964 Cole 317/114
- 3,201,786 8/1965 Andersen et al. 340/381
- 3,390,309 6/1968 McGrew, Jr. 361/349 X
- 3,443,162 5/1969 Nudelmont 317/118
- 3,728,586 4/1973 Inhelder et al. 317/114

FOREIGN PATENT DOCUMENTS

28607 12/1932 Netherlands .

Primary Examiner—Susan J. Lucas
Attorney, Agent, or Firm—Koppel & Harris

[57] CLAIM

The ornamental design for an electrical power module, as shown and described.

DESCRIPTION

FIG. 1 is a front perspective view of an electrical power module showing my new design; FIG. 2 is a rear perspective view thereof; FIGS. 3 and 4 are respectively front and rear elevational views thereof on a reduced scale; FIGS. 5 and 6 are respectively left and right elevational views thereof on a reduced scale; and FIGS. 7 and 8 are respectively top and bottom plan views thereof on a reduced scale.

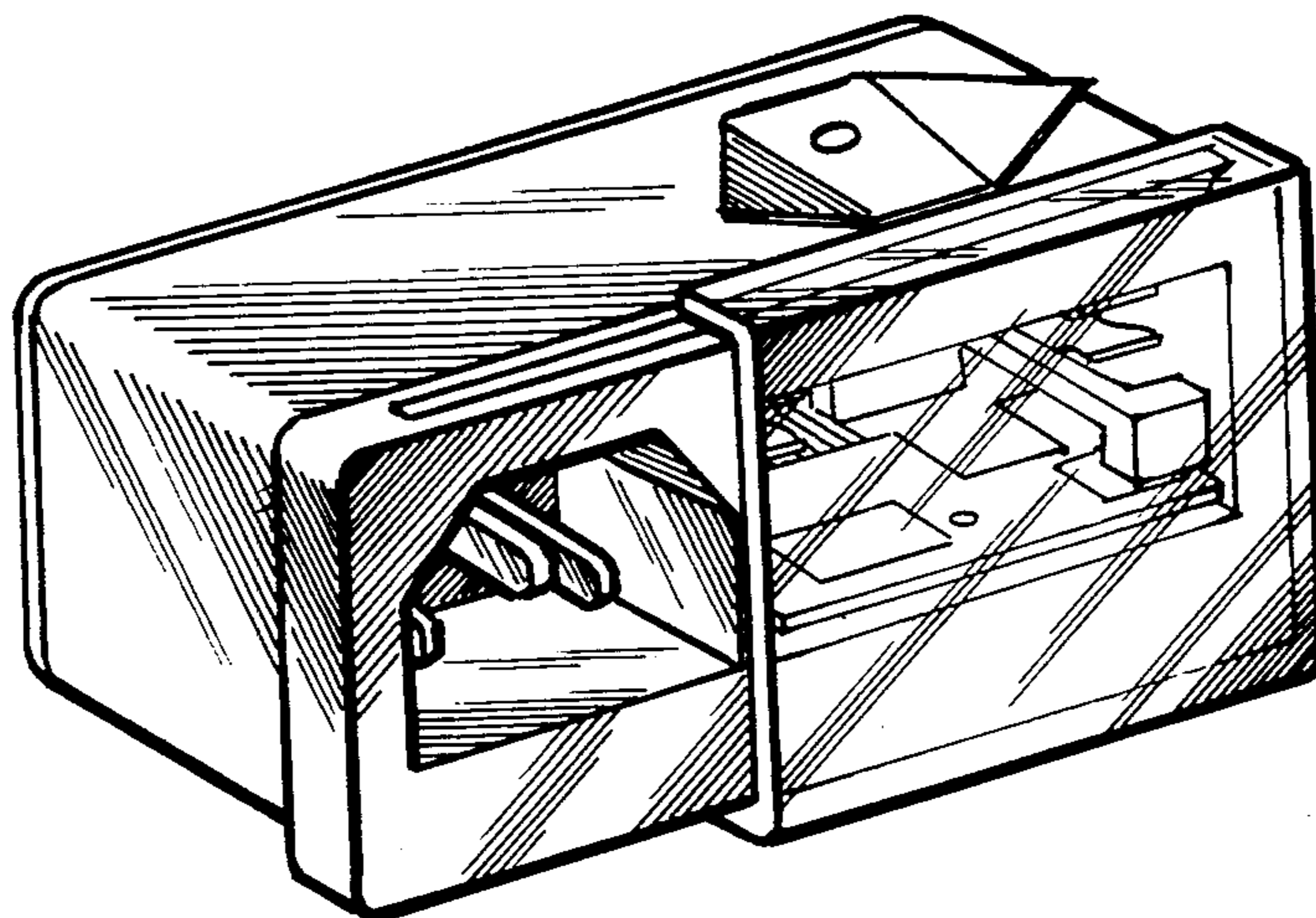

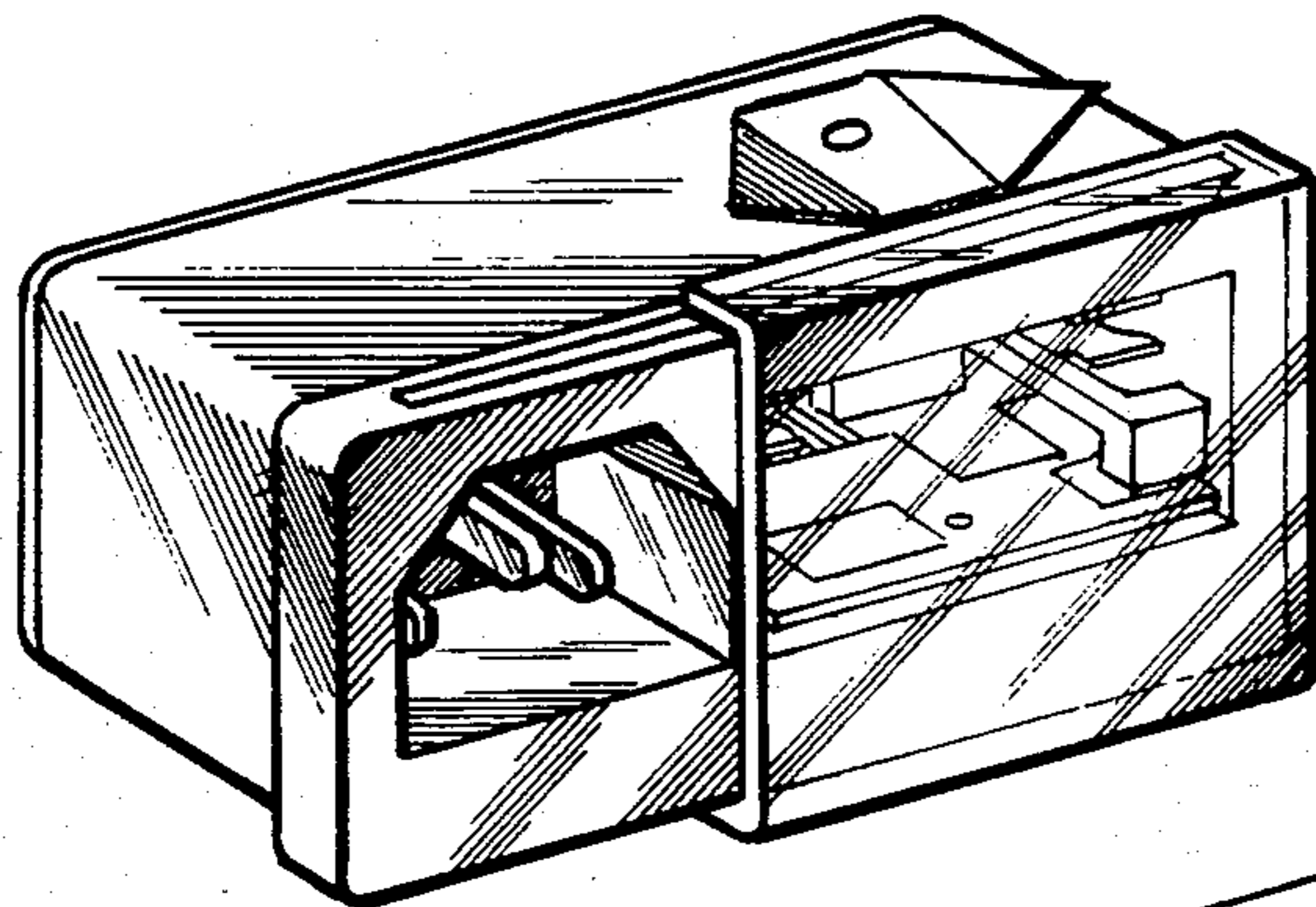

Fig. 1.

Fig. 2.

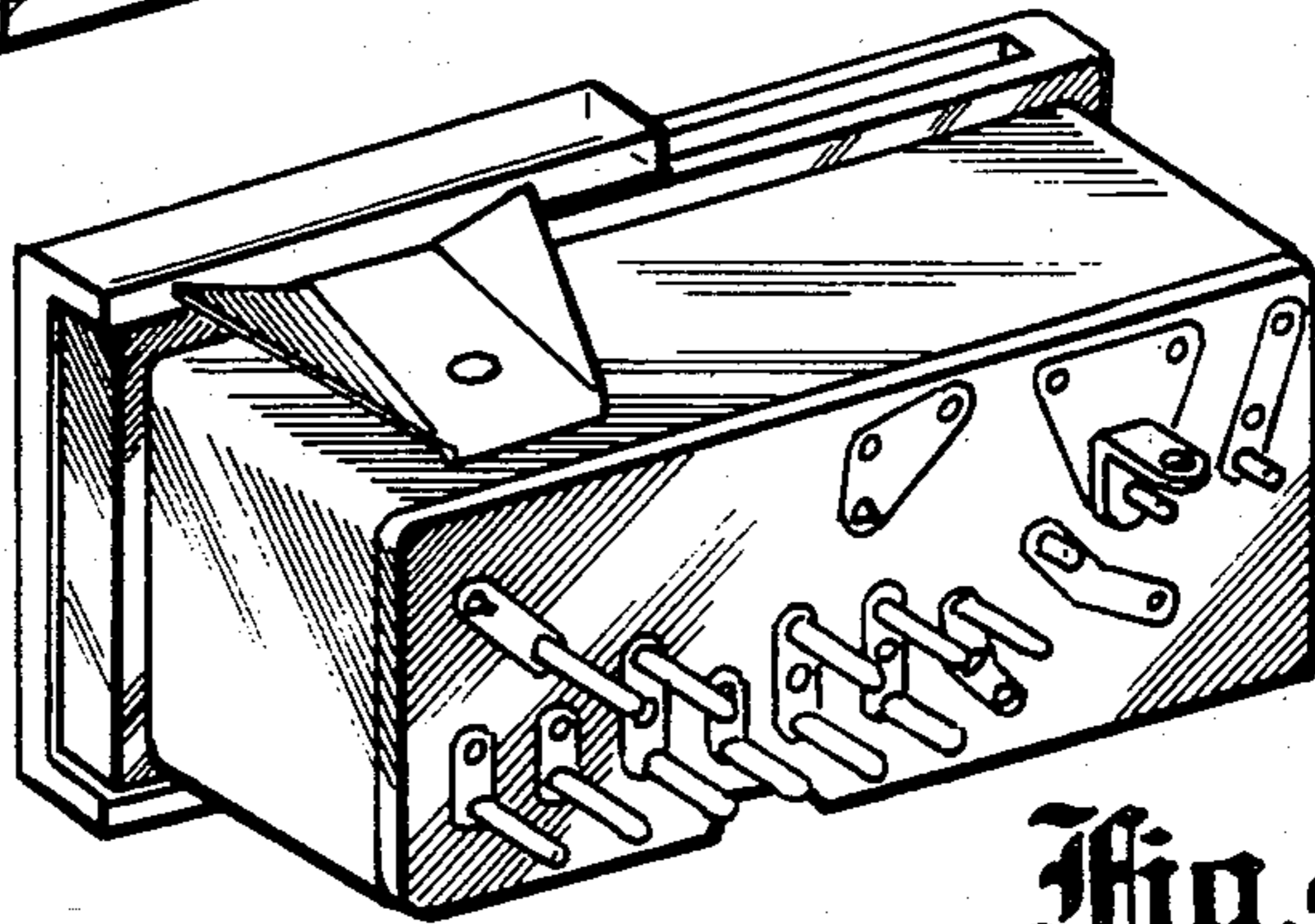

Fig. 3.

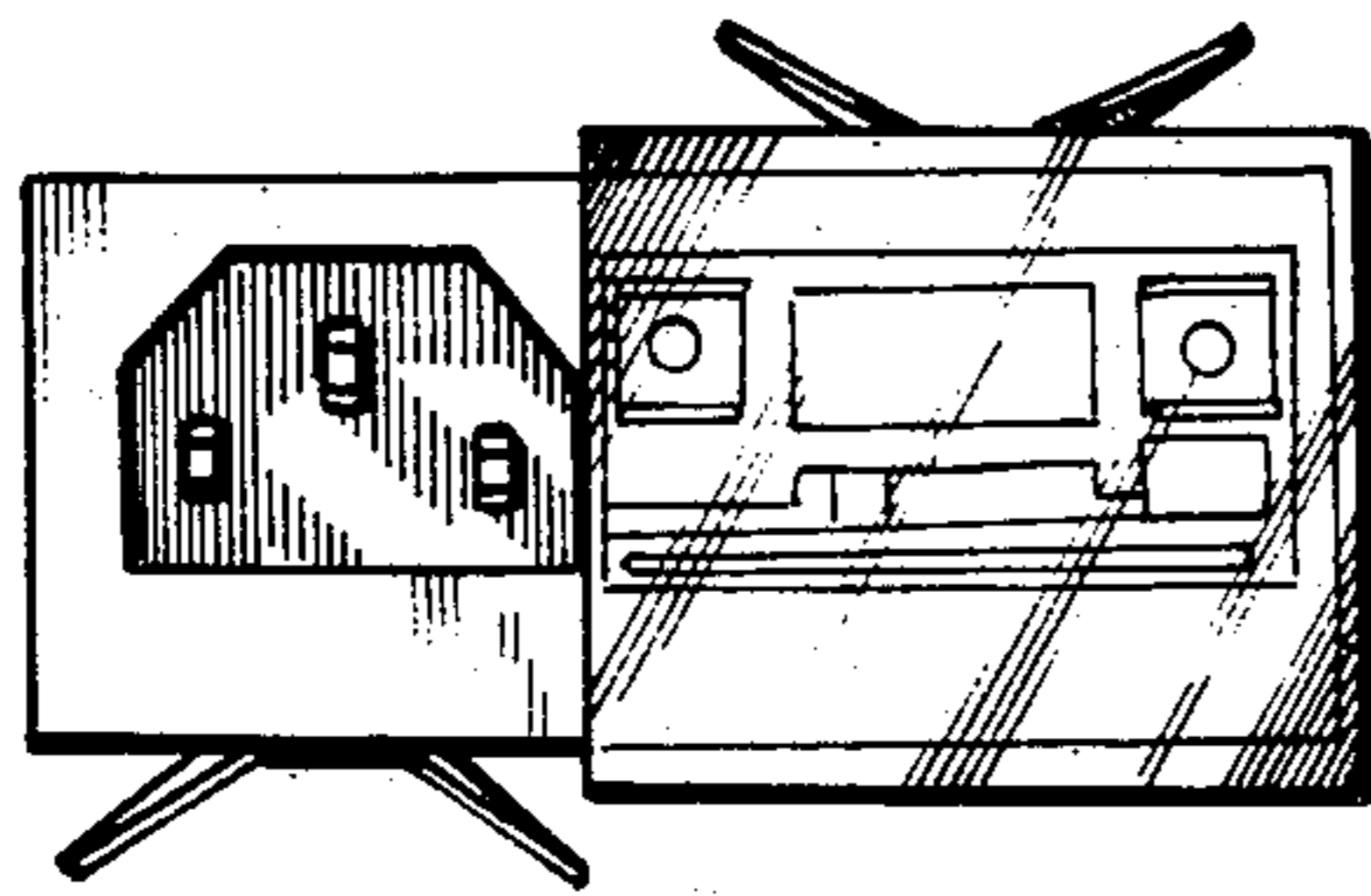

Fig. 4.

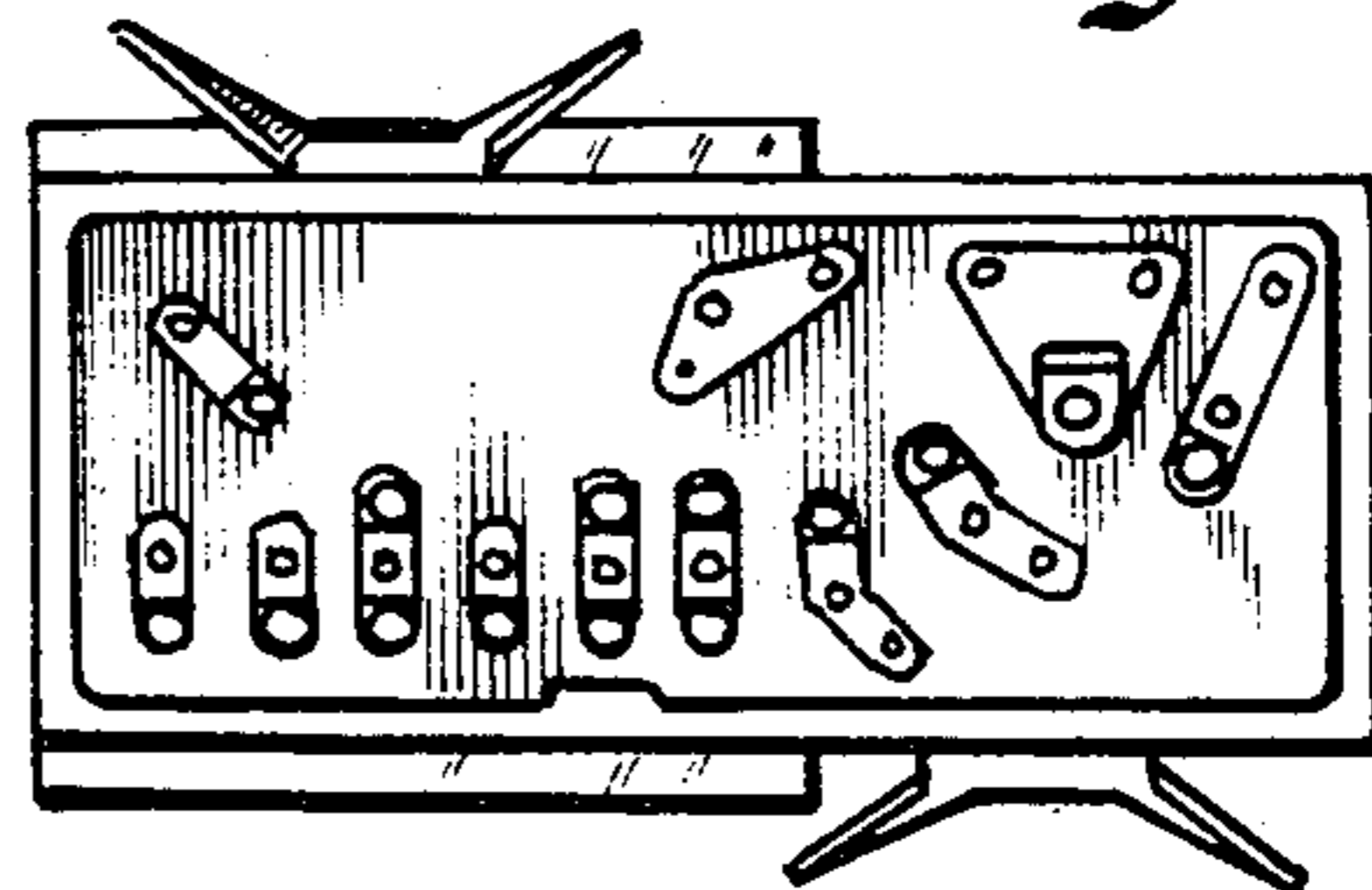

Fig. 5.

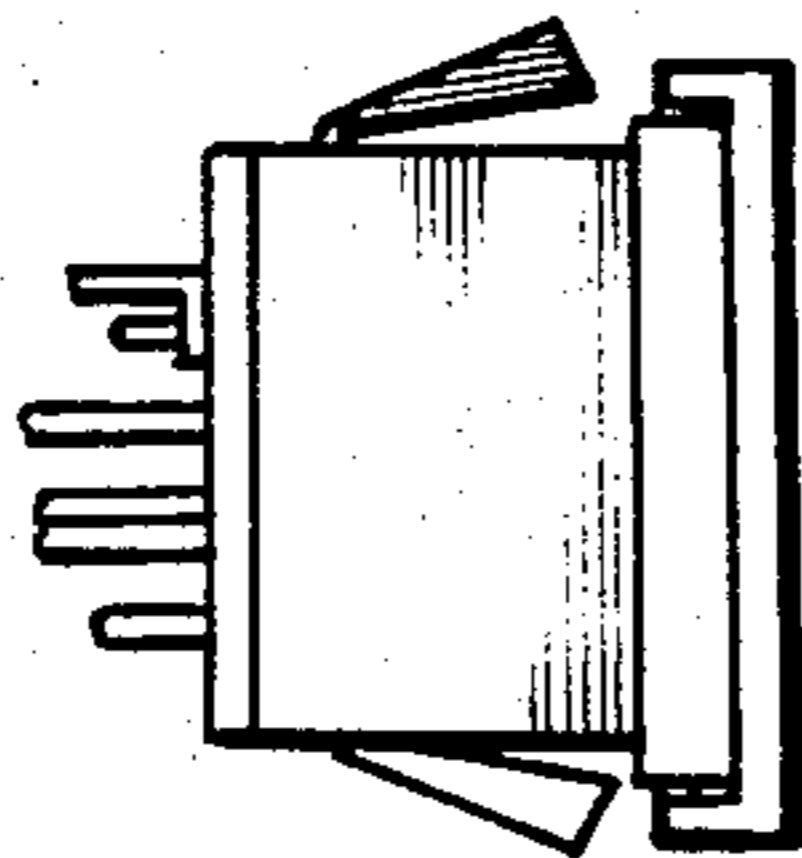

Fig. 6.

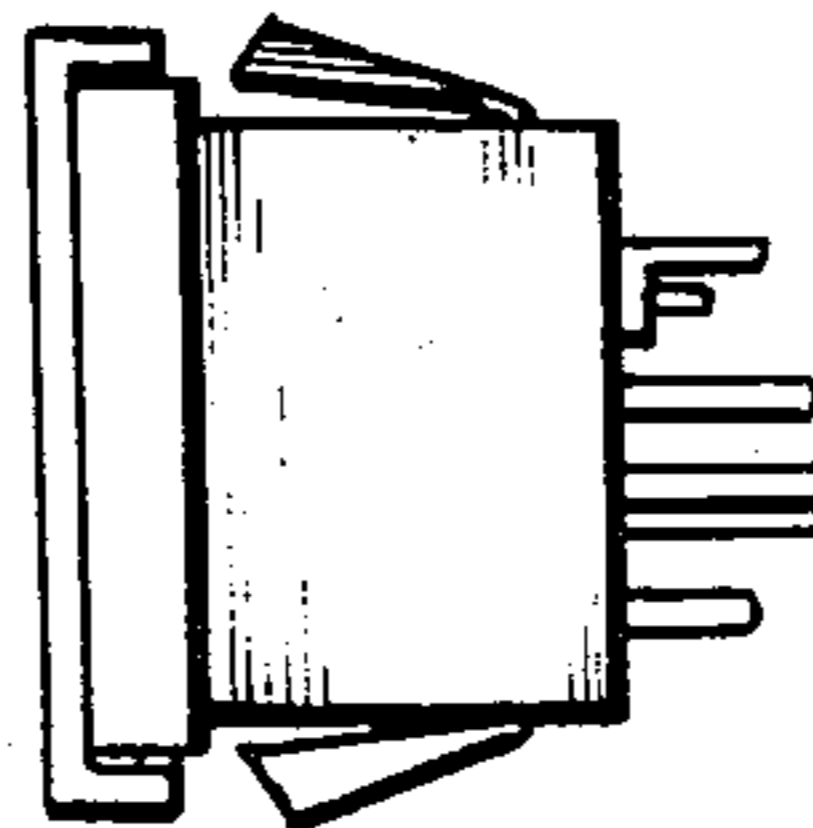

Fig. 7.

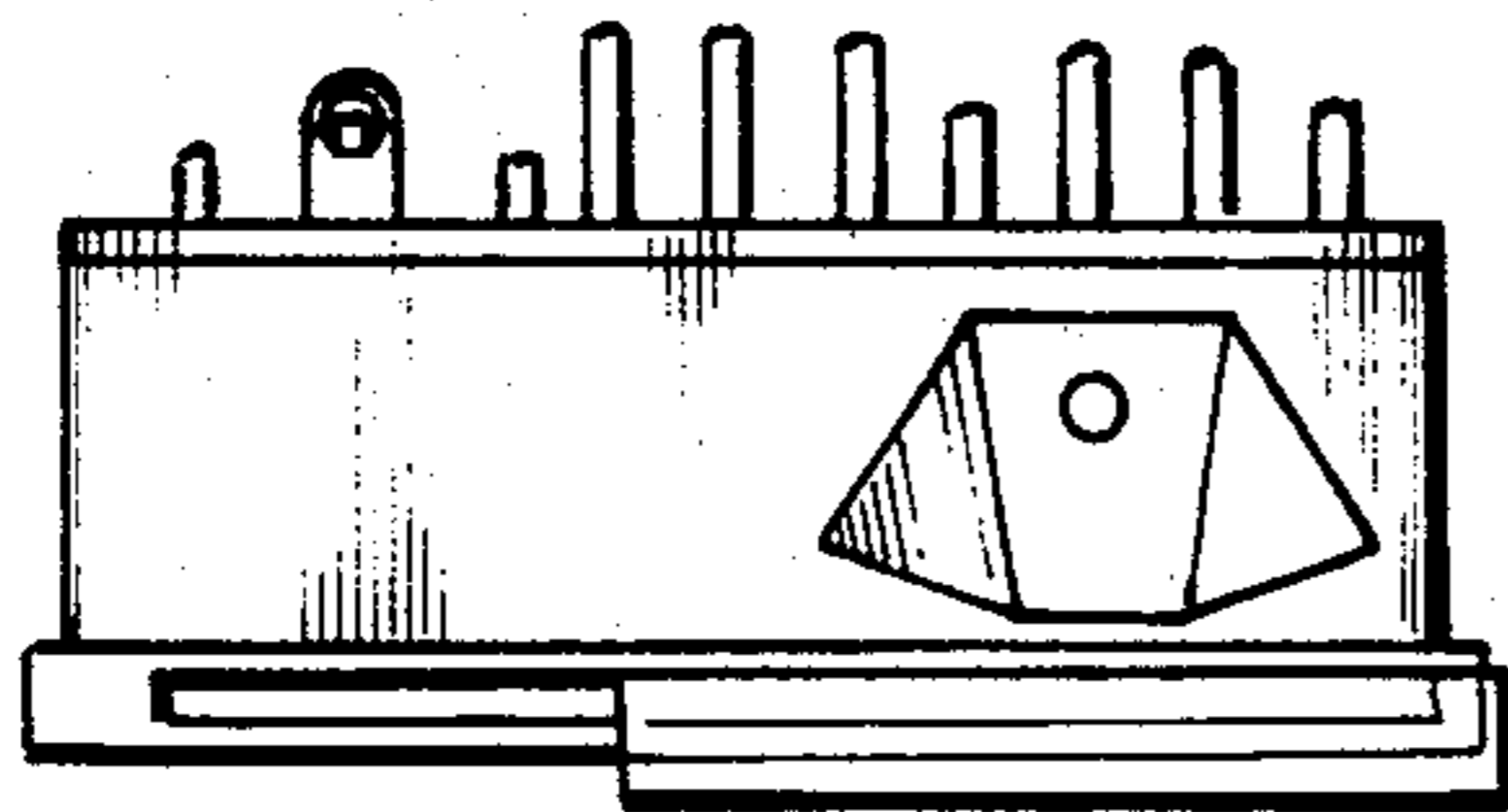

Fig. 8.

