

- [54] **MOTORCYCLE SADDLEBAG**
- [75] **Inventors: John A. Heiman, Waukesha; Richard D. Miller, Oconomowoc, both of Wis.**
- [73] **Assignee: Harley-Davidson Motor Co., Inc., Milwaukee, Wis.**
- [**] **Term: 14 Years**
- [21] **Appl. No.: 428,409**
- [22] **Filed: Sep. 29, 1982**
- [52] **U.S. Cl. D12/158; D3/48; D3/77**
- [58] **Field of Search D12/158; D3/48, 52, D3/71, 77, 79; 224/42.11, 32 R, 32 A, 34, 30 R**
- [56] **References Cited**
- U.S. PATENT DOCUMENTS**
- D. 272,428 1/1984 Kelley D12/158

OTHER PUBLICATIONS

Rocky Cycle Co., Catalog ©1968, p. 7, Universal Bag, top left side of page.

Primary Examiner—James M. Gandy

[57] **CLAIM**

The ornamental design for a motorcycle saddlebag, as shown.

DESCRIPTION

FIG. 1 is a front elevation view of a motorcycle saddlebag, showing our new design;
FIG. 2 is a side elevation view thereof taken from the right of FIG. 1;
FIG. 3 is a top plan view thereof;
FIG. 4 is a rear elevation view thereof;
FIG. 5 is a side elevation view thereof taken from the left of FIG. 1; and,
FIG. 6 is a bottom plan view thereof.

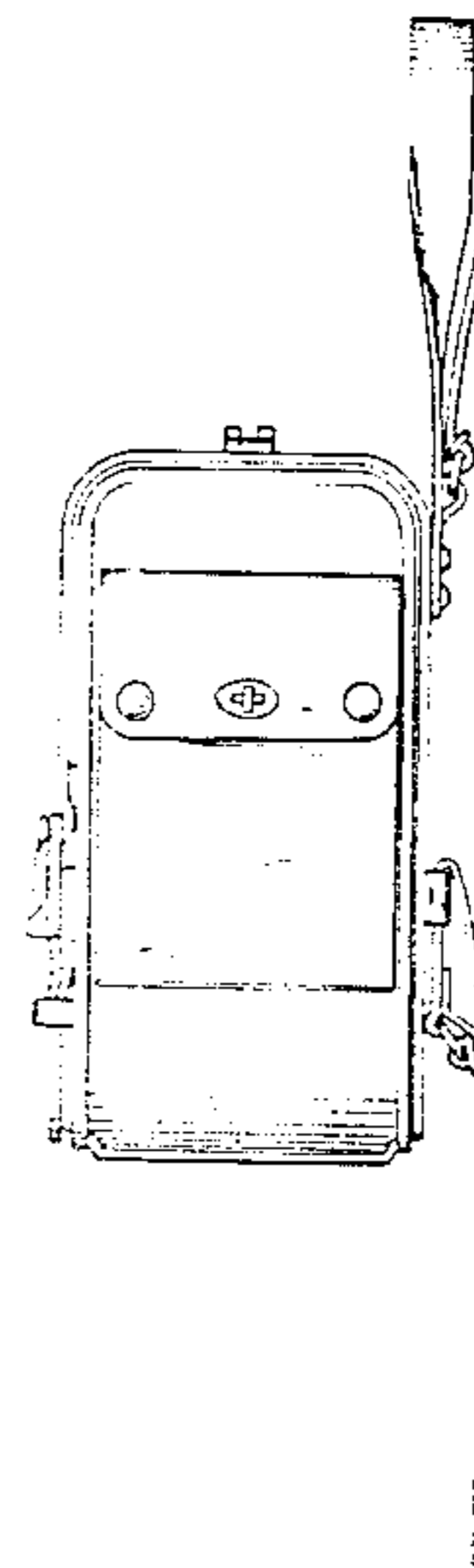
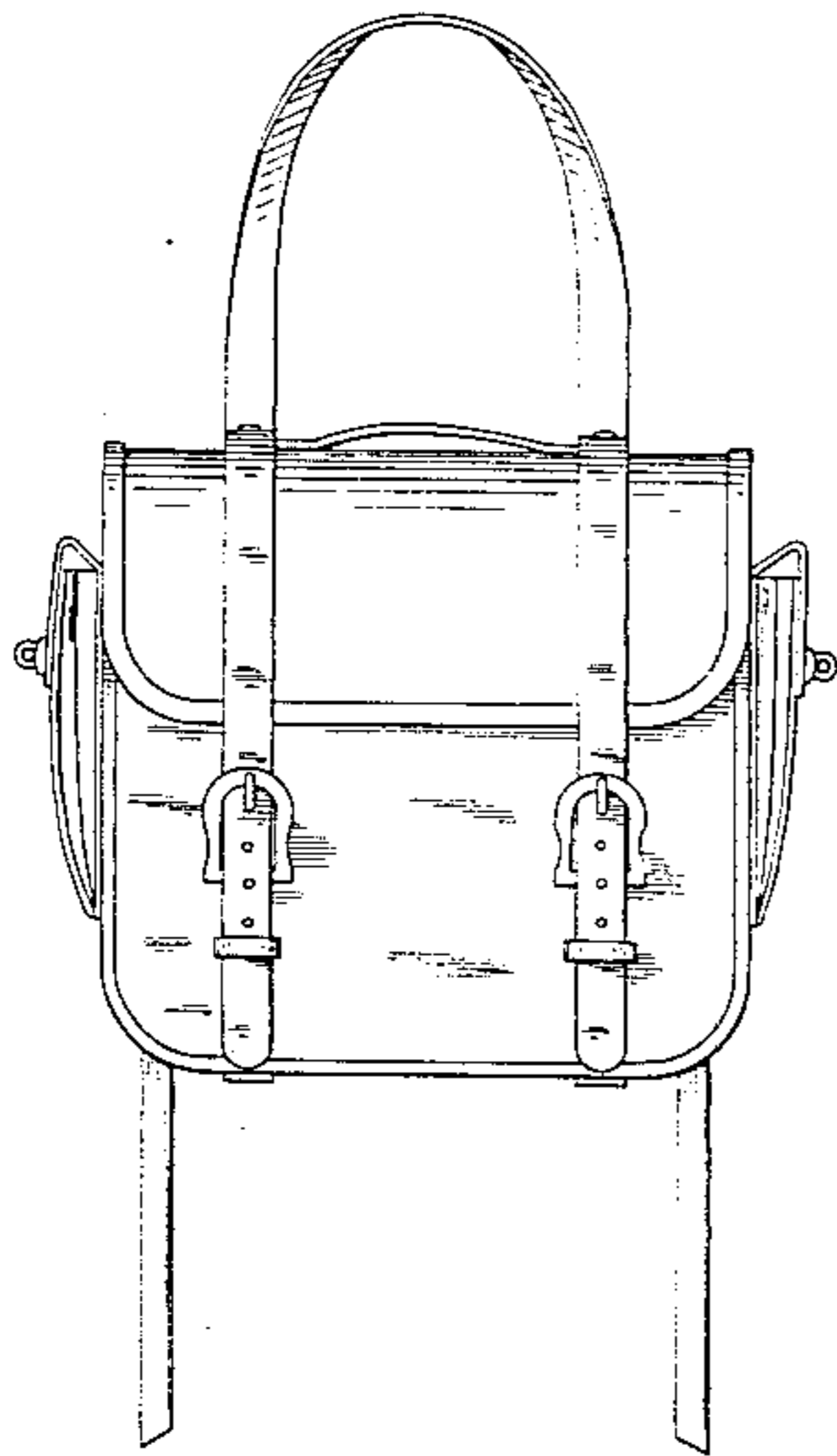

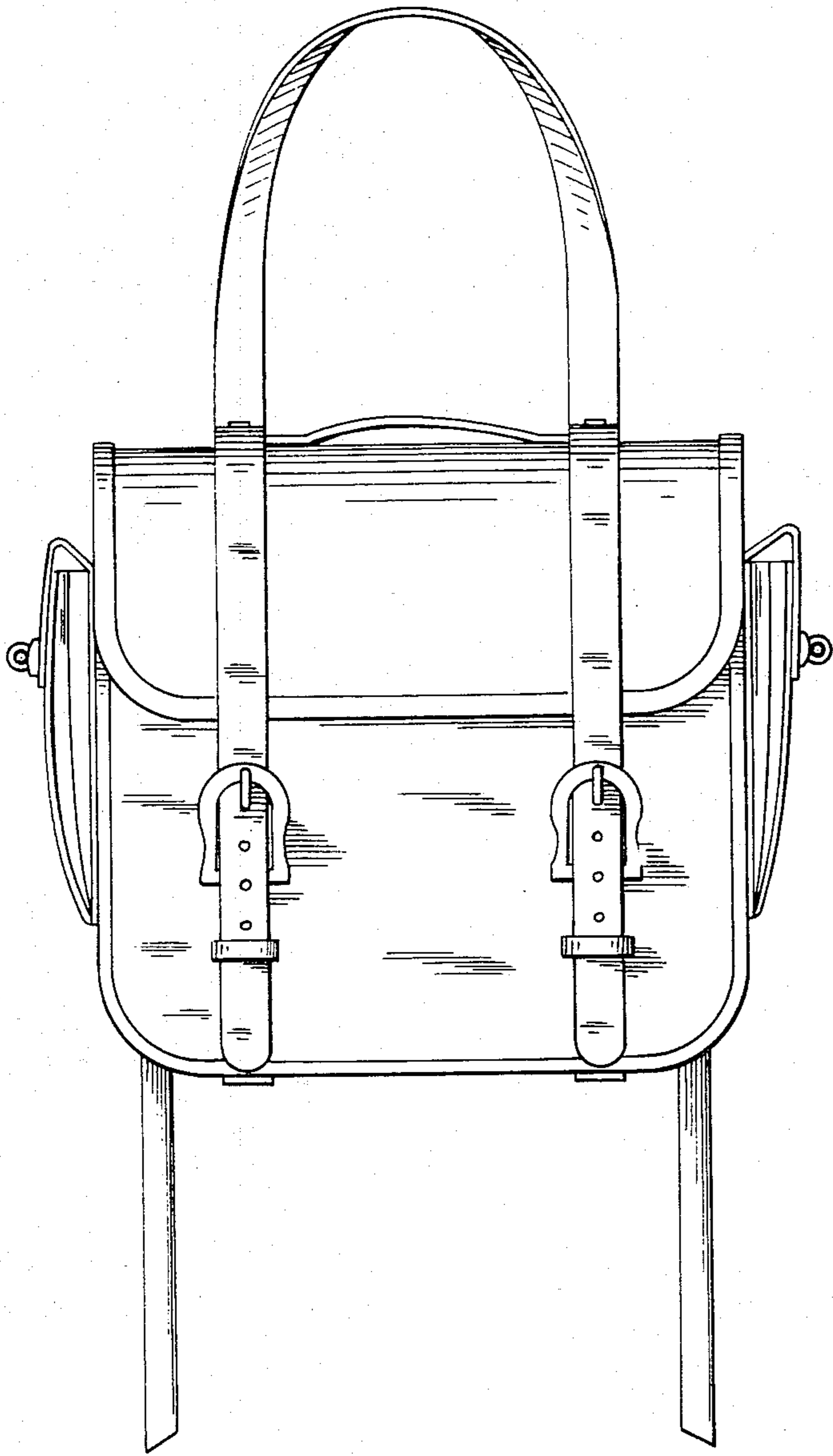

FIG. 1

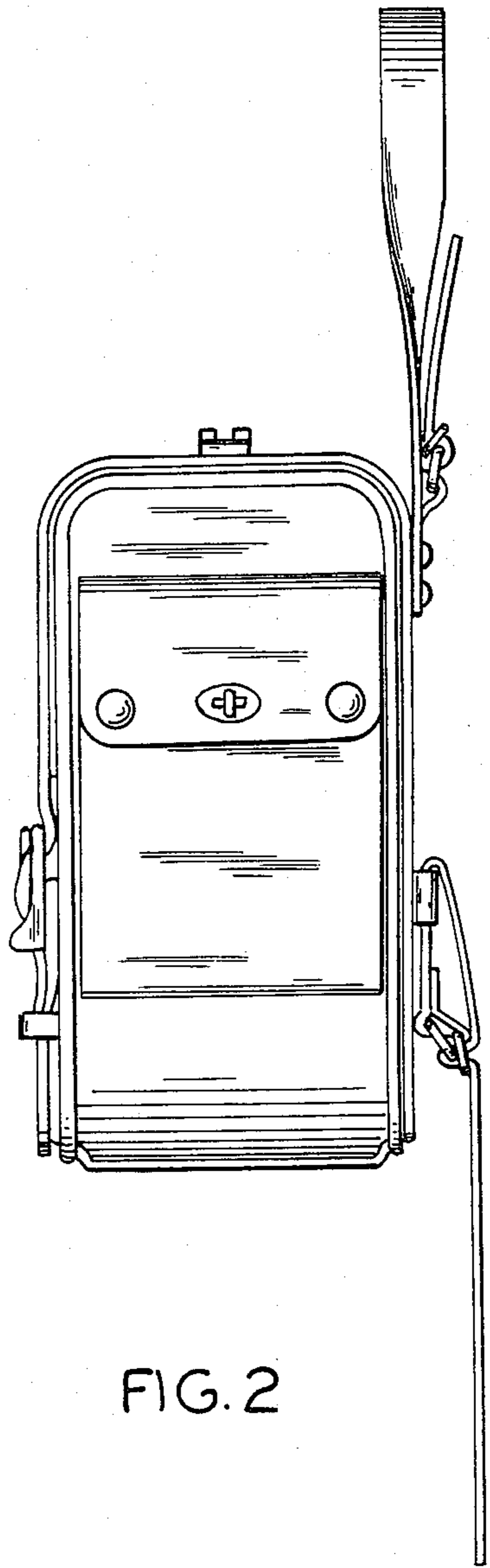

FIG. 2

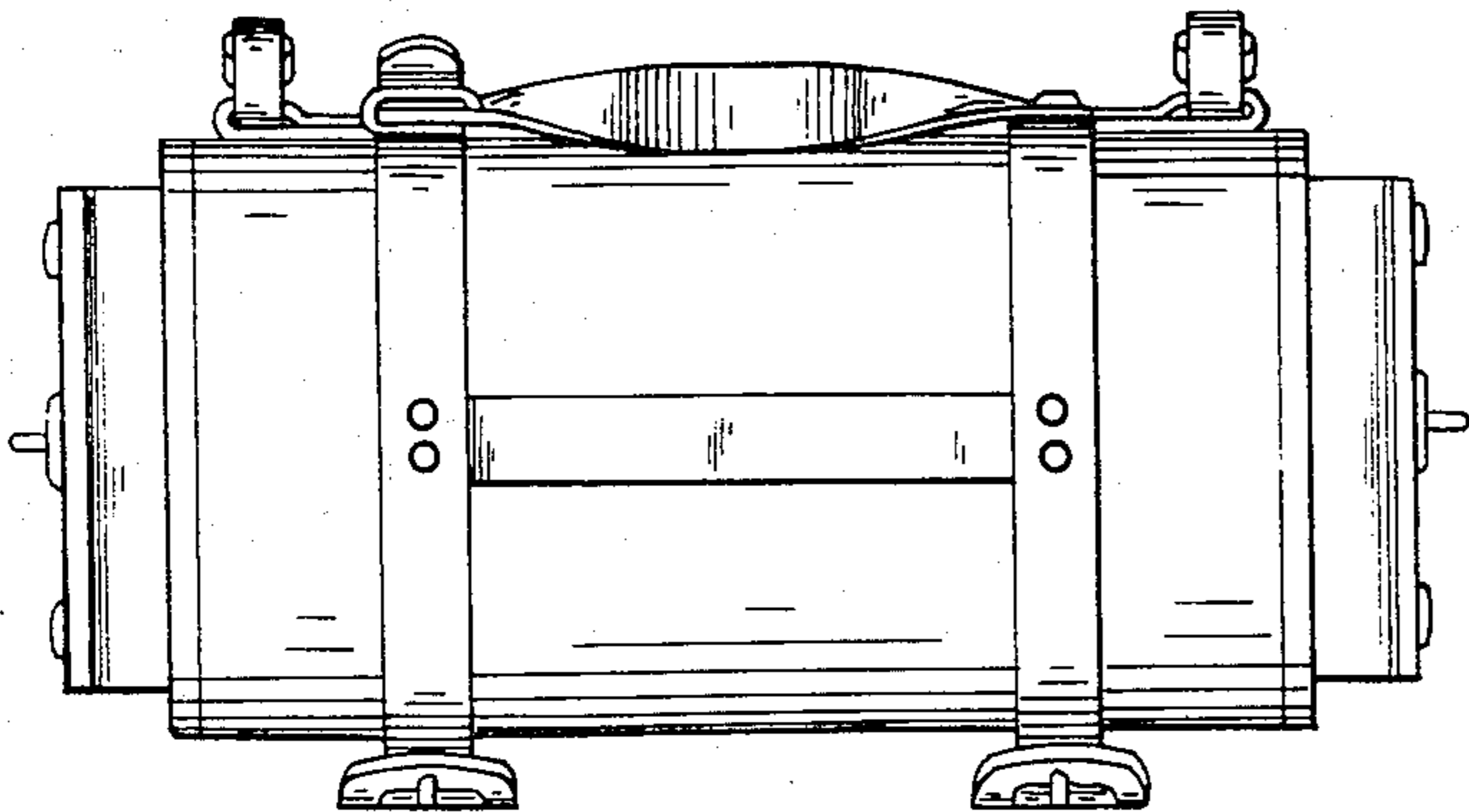

FIG. 3

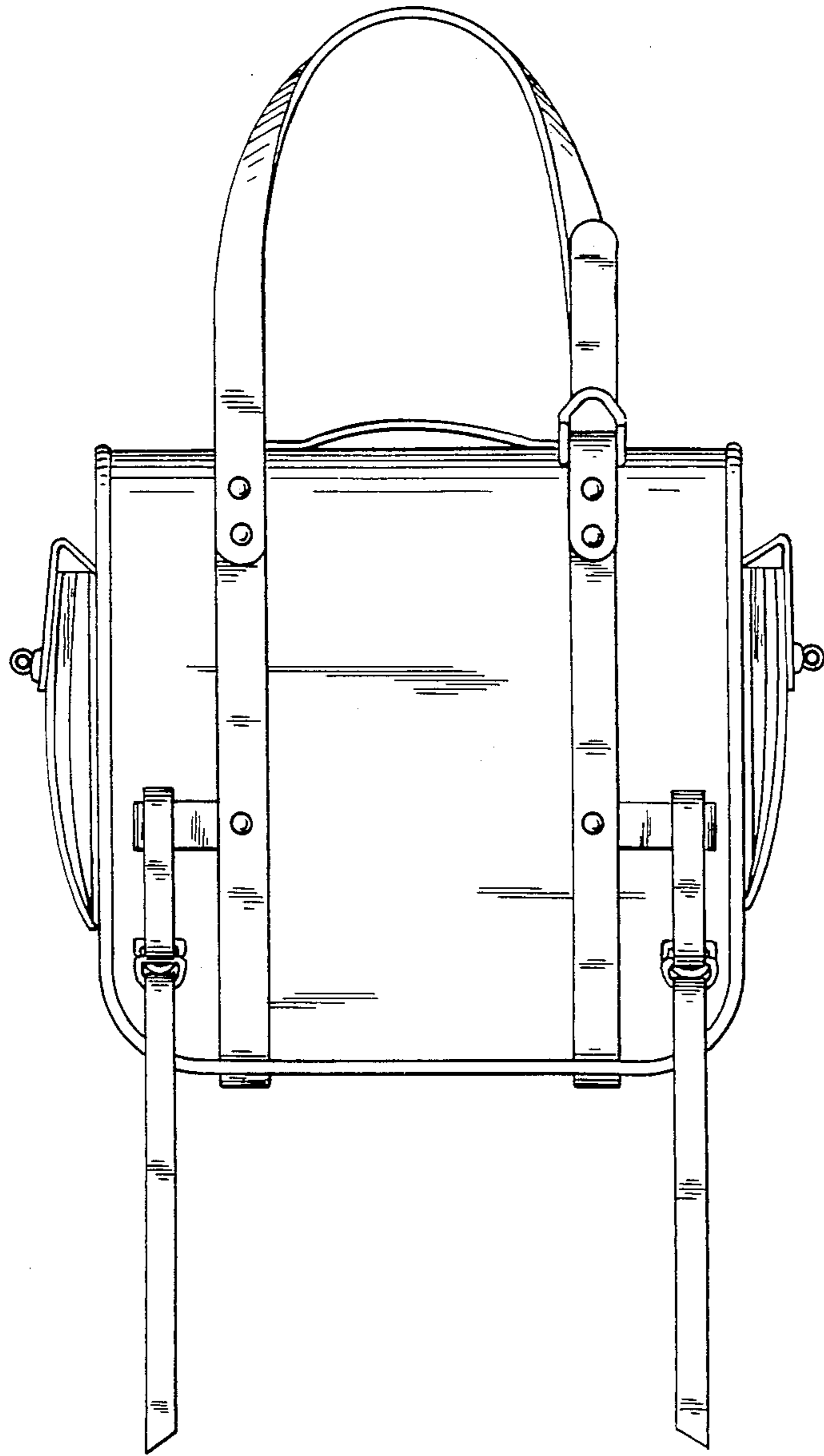

FIG. 4

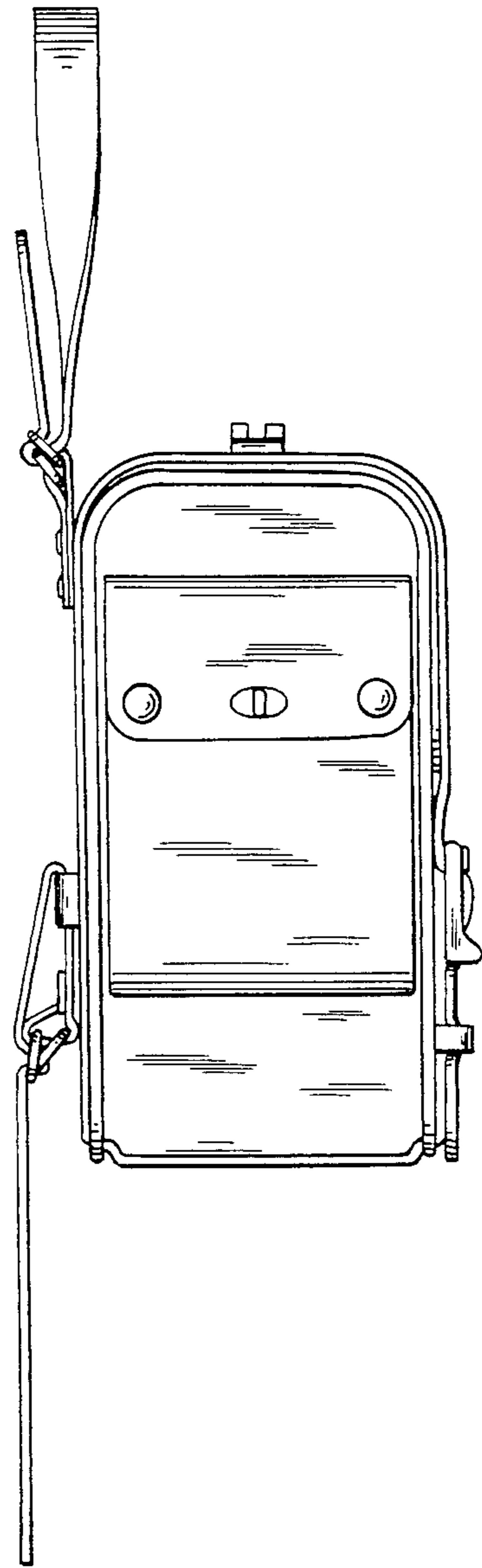

FIG. 5

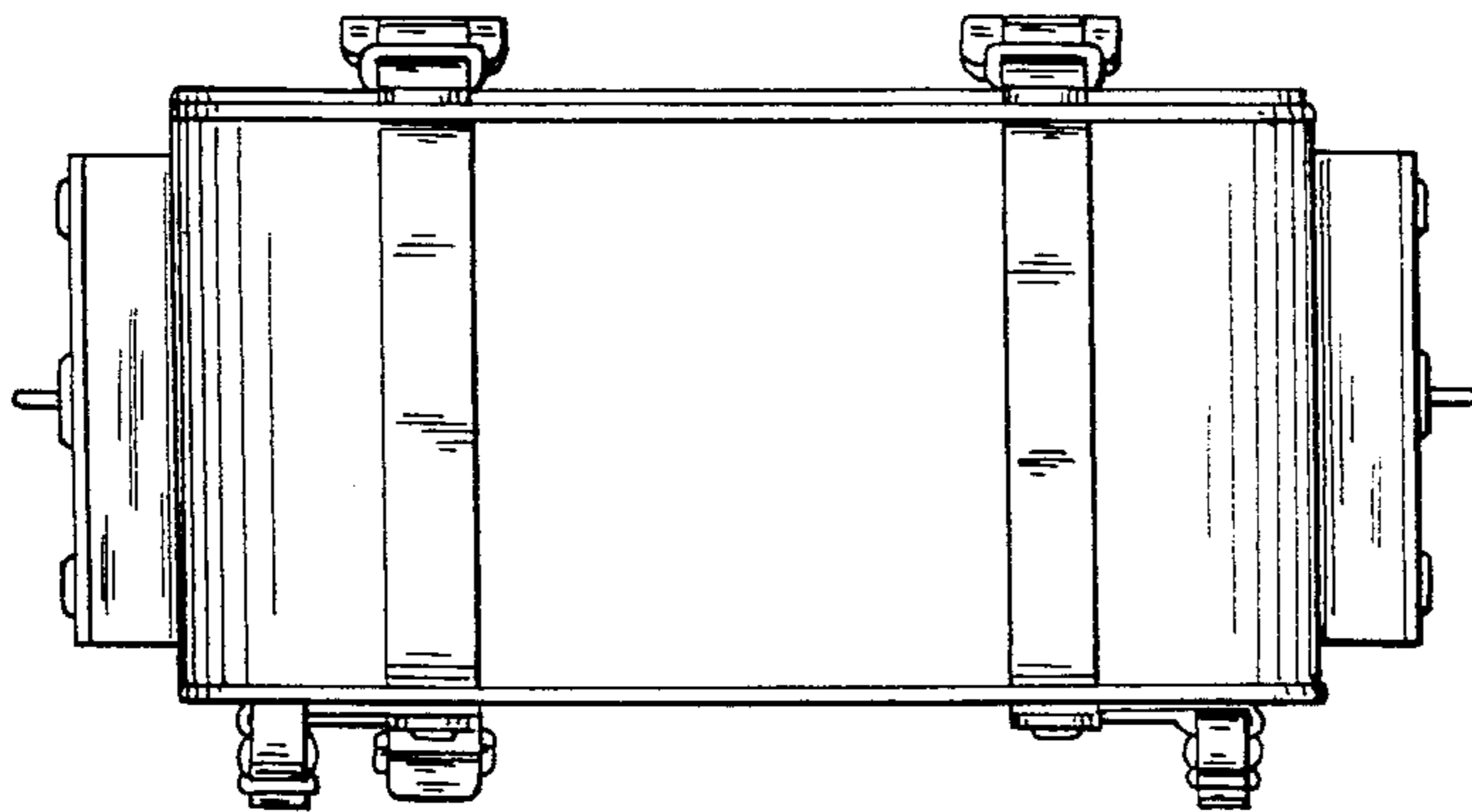

FIG. 6