

[54] **TOY TAKE-APART ENGINE**

[76] Inventors: **Robert L. Carignan**, 1160 N. Market St., Elizabethtown, Pa. 17022; **Timothy Effler**, 6414 Aspen Way, Cincinnati, Ohio 45225; **John E. Holden**, R.D. #1, Box 315, Mount Joy, Pa. 17552

[**] Term: **14 Years**

[21] Appl. No.: **409,077**

[22] Filed: **Aug. 18, 1982**

[52] U.S. Cl. **D21/125; D19/62**

[58] Field of Search **D21/109, 120, 124, 125, D21/144; 46/1 A, 14, 39, 47, 174; D19/62, 63, 64; D15/31**

[56] **References Cited**

U.S. PATENT DOCUMENTS

D. 81,328 6/1930 Giesler D21/125

D. 217,272 4/1970 Genin D21/125
D. 253,313 10/1979 Josvanger D19/62

FOREIGN PATENT DOCUMENTS

12167 11/1956 Fed. Rep. of Germany 446/491

OTHER PUBLICATIONS

"Car Life", 7-1970, front page, Engine.

Primary Examiner—Charles A. Rademaker

[57] **CLAIM**

The ornamental design for a toy take-apart engine, substantially as shown.

DESCRIPTION

FIG. 1 is a front perspective view of a toy take-apart engine showing our new design; FIG. 2 is a front elevational view thereof; FIG. 3 is a right side elevational view thereof; FIG. 4 is a rear elevational view thereof; and, FIG. 5 is a top plan view thereof.

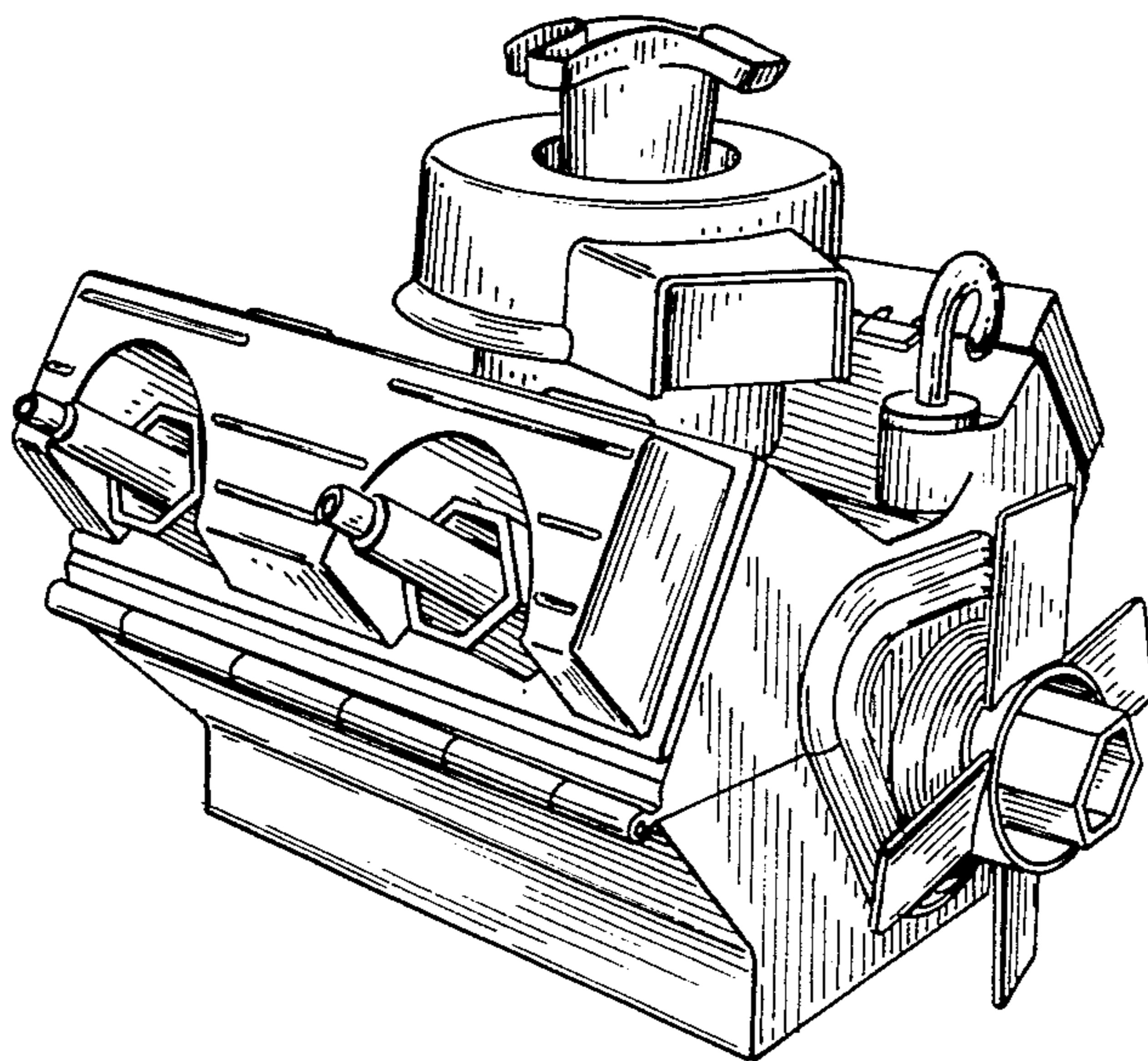

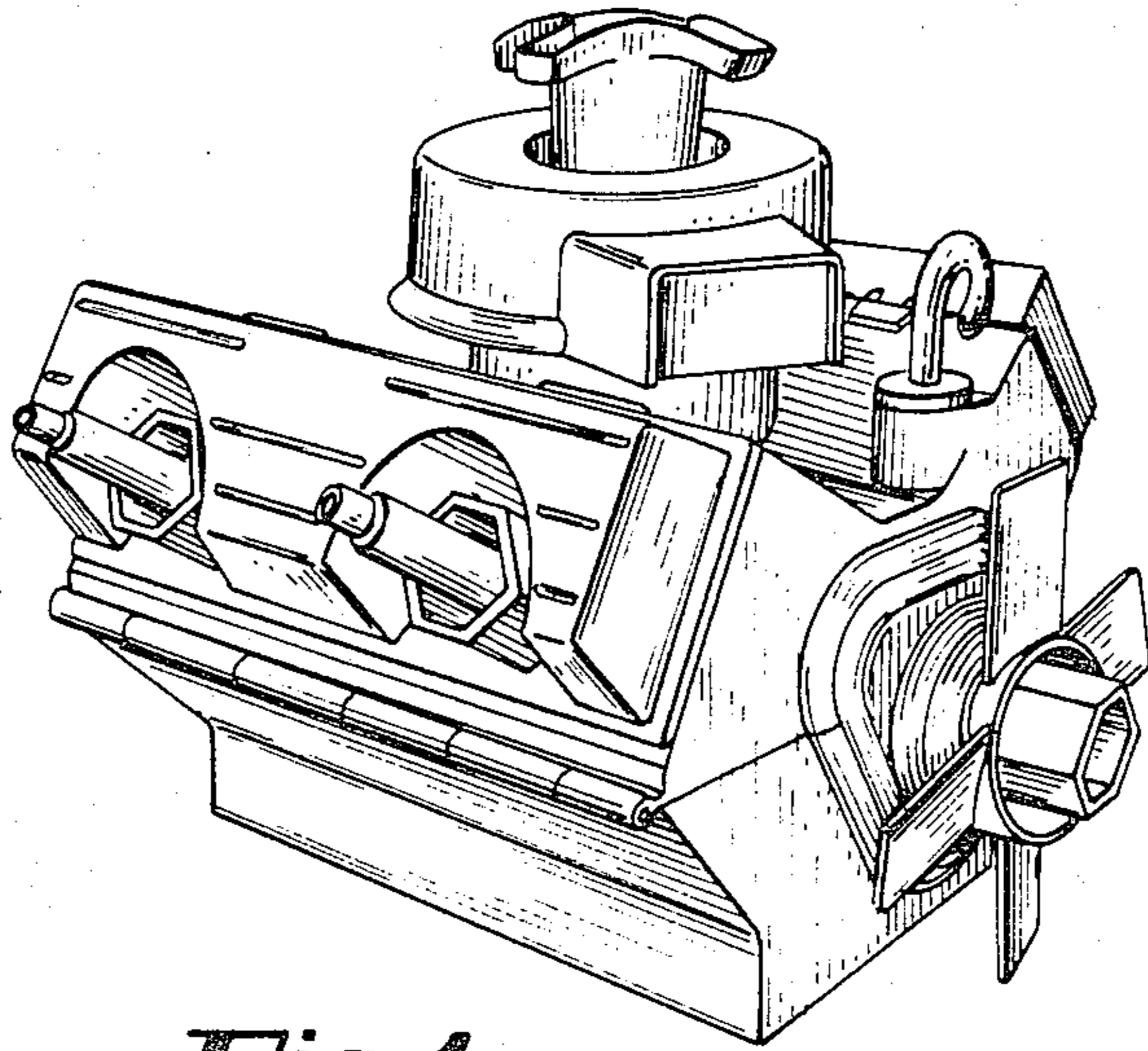

Fig. 1

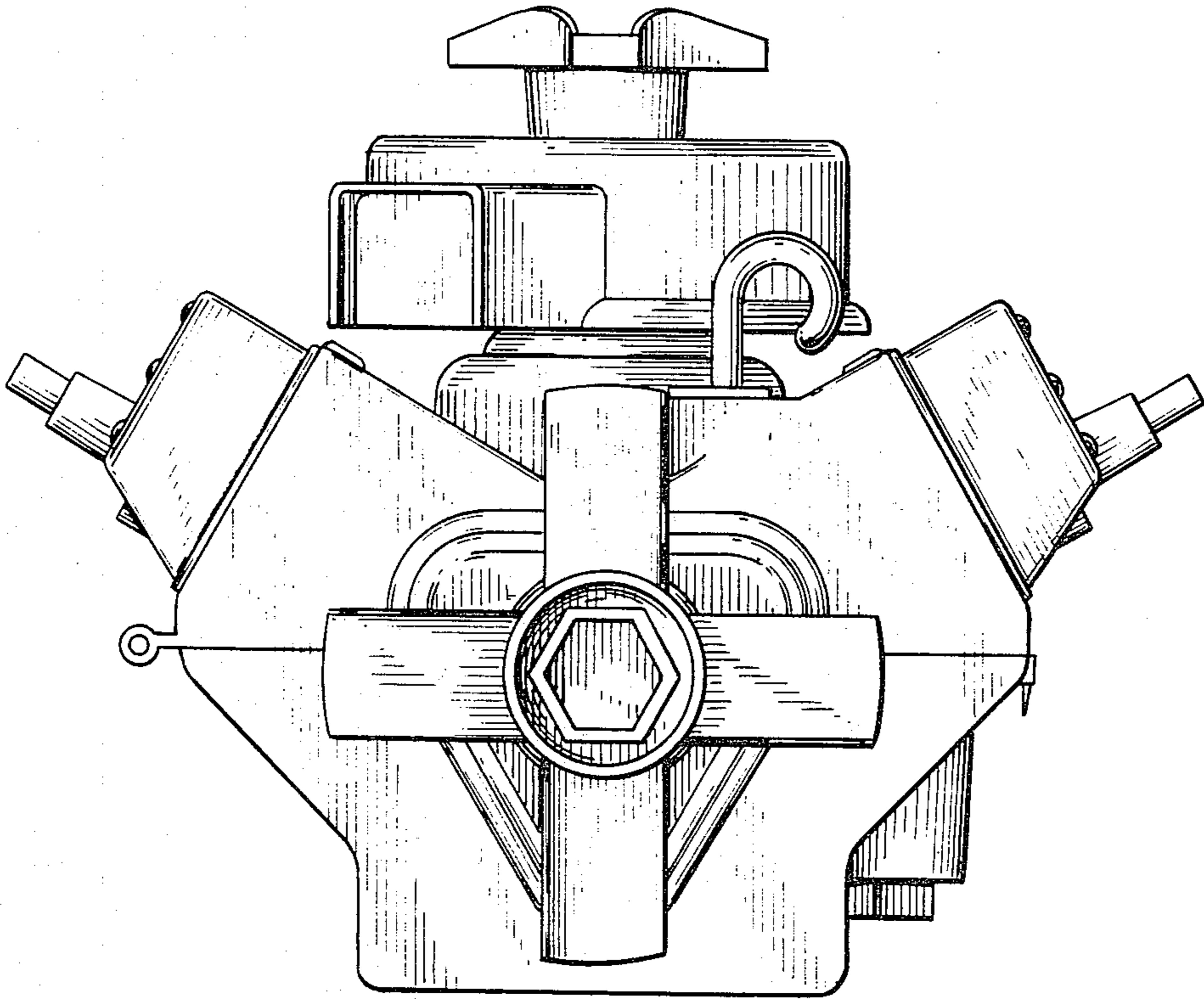

Fig. 2

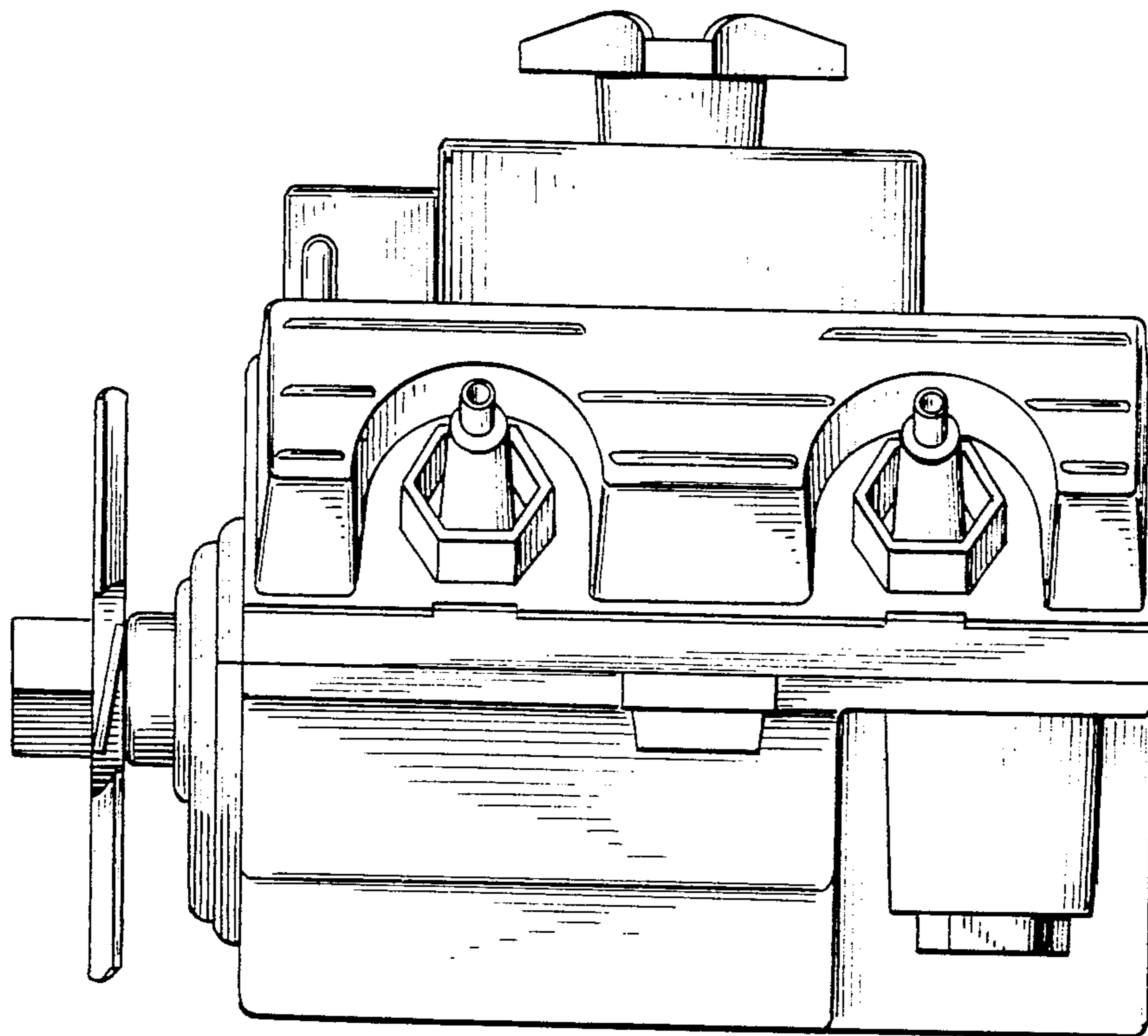

Fig. 3

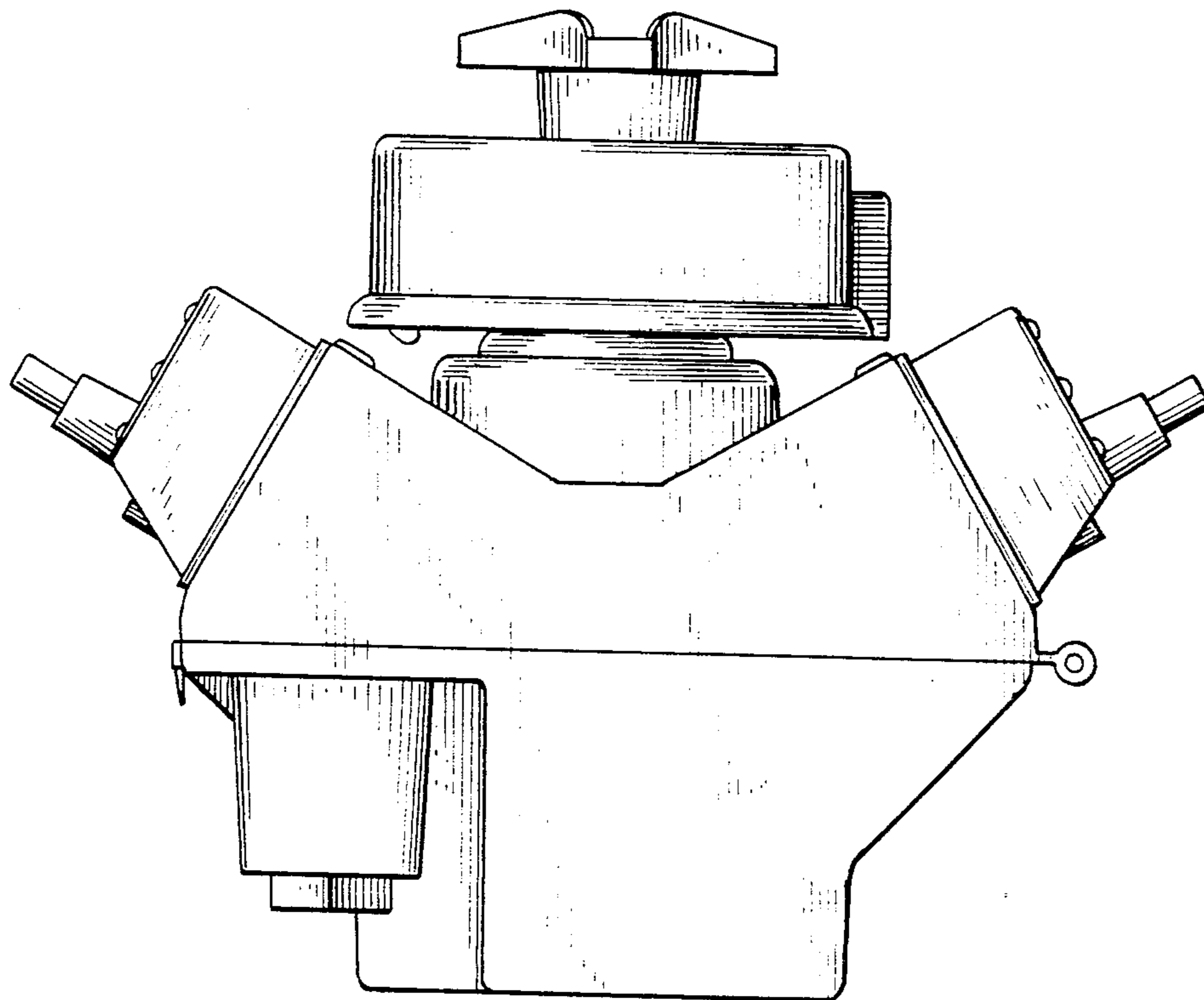

Fig. 4

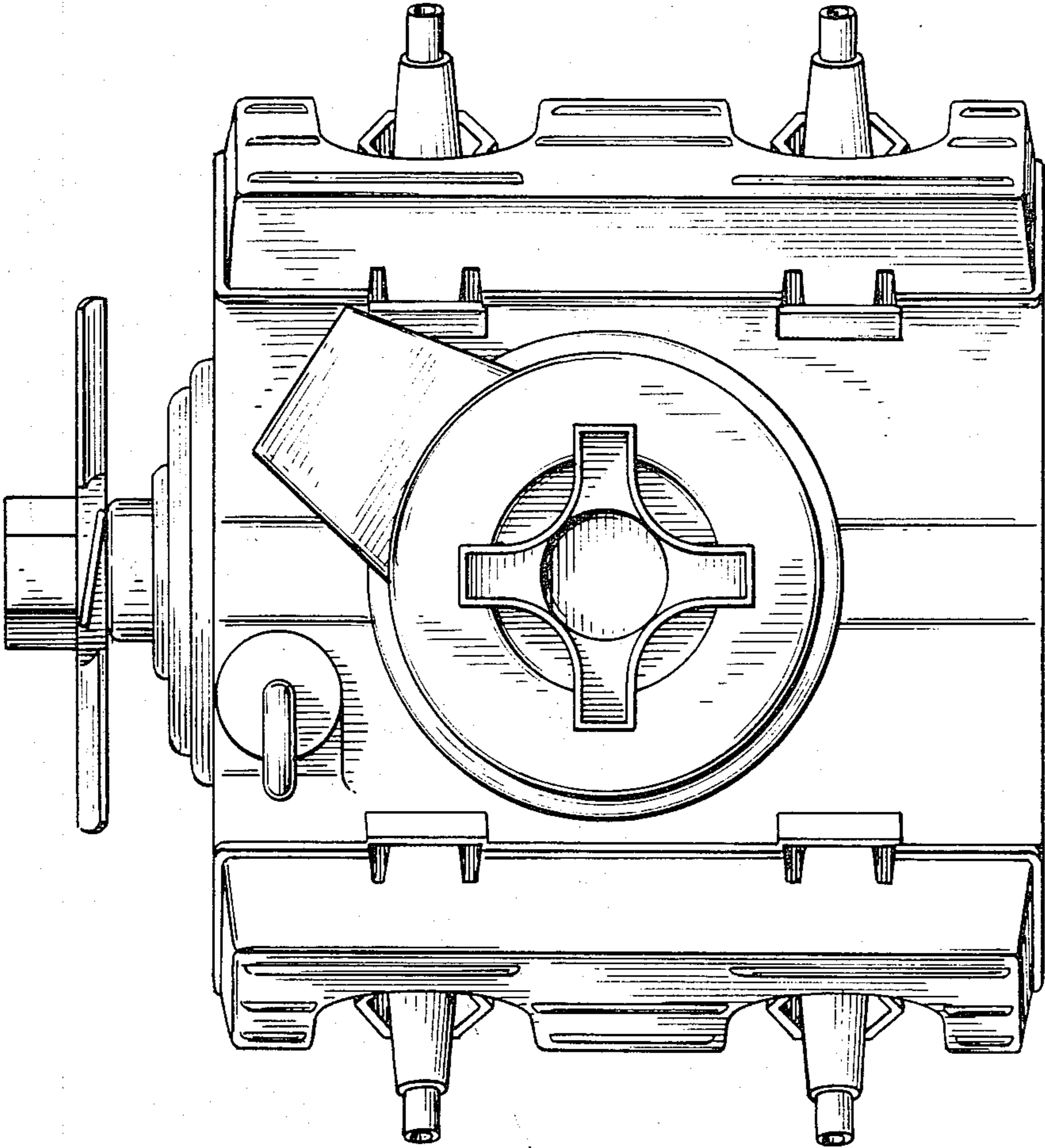

Fig. 5