

- [54] **CATAMARAN-HULLED SAILING SKIFF**
- [75] **Inventor: Ramón Vila Enfedaque, Barcelona, Spain**
- [73] **Assignee: Fibrester, S.A., Barcelona, Spain**
- [**] **Term: 14 Years**
- [21] **Appl. No.: 223,096**
- [22] **Filed: Jan. 7, 1981**
- [52] **U.S. Cl. D12/304**
- [58] **Field of Search D12/304, 310; 114/61, 114/39**

- [56] **References Cited**
- U.S. PATENT DOCUMENTS**
- D. 225,904 1/1973 Critcher D12/304
 - D. 228,031 7/1973 Tabur D12/310
 - 3,548,773 12/1970 Laughlin 114/61

OTHER PUBLICATIONS

The 1976 Sailboat and Equipment Directory, pub. 10/1/75, p. 194, Hobie 12 Sailboat at left of page.

Domus, Maggio 1977, p. 47, "Baloo Catamarano", Sailboat on page.

Primary Examiner—Alan P. Douglas
Attorney, Agent, or Firm—Michael J. Striker

[57] **CLAIM**

The ornamental design for a catamaran-hulled sailing skiff, substantially as shown and described.

DESCRIPTION

FIG. 1 is a side elevational view of a catamaran-hulled sailing skiff with the mast and sail broken away for convenience of illustration;
FIG. 2 is a top plan view thereof;
FIG. 3 is a front elevational view thereof with the sail and uppermost portion of the mast removed for convenience of illustration;
FIG. 4 is a rear elevational view thereof with the sail and uppermost portion of the mast removed for convenience of illustration; and
FIG. 5 is a perspective view thereof with the uppermost portion of the sail and mast removed for convenience of illustration.

The appearance of the side of the catamaran-hulled sailing skiff not shown in the drawing is identical with the appearance of the side shown in FIG. 1.

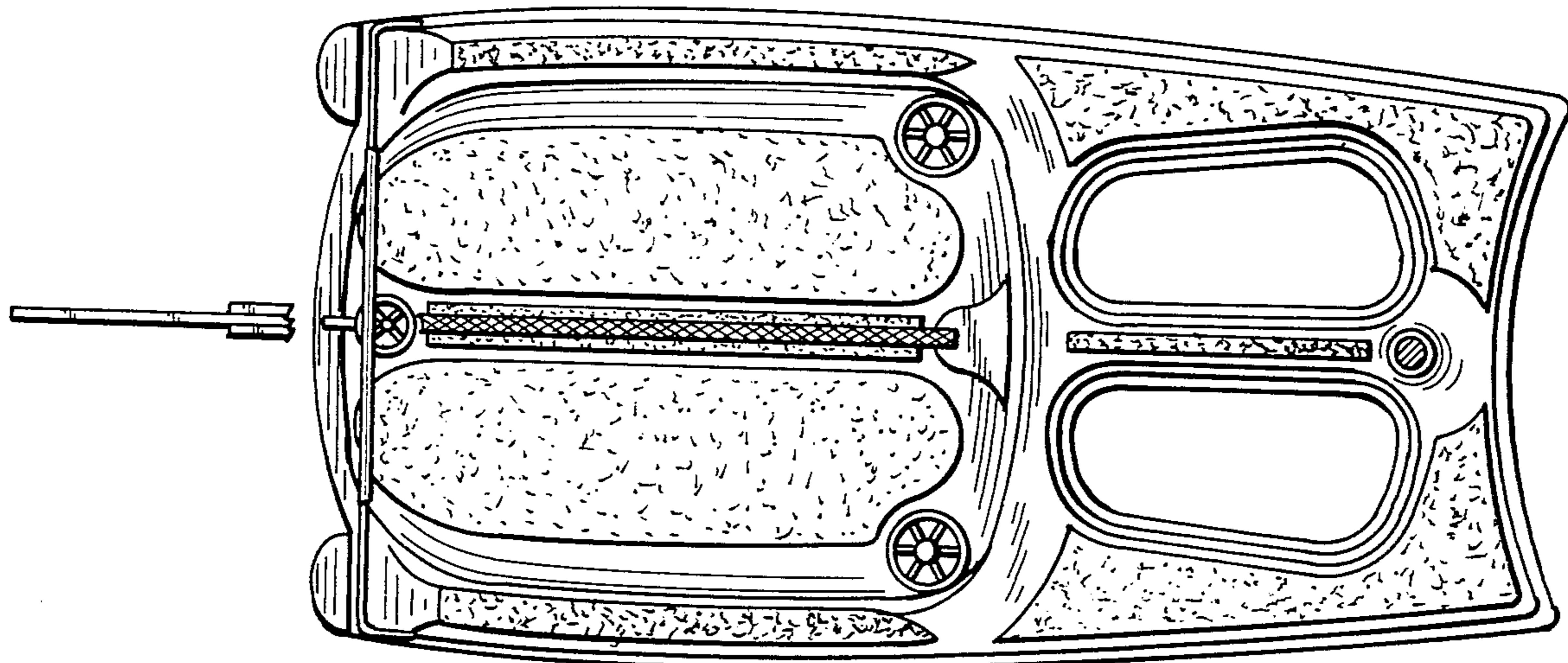

FIG. 1

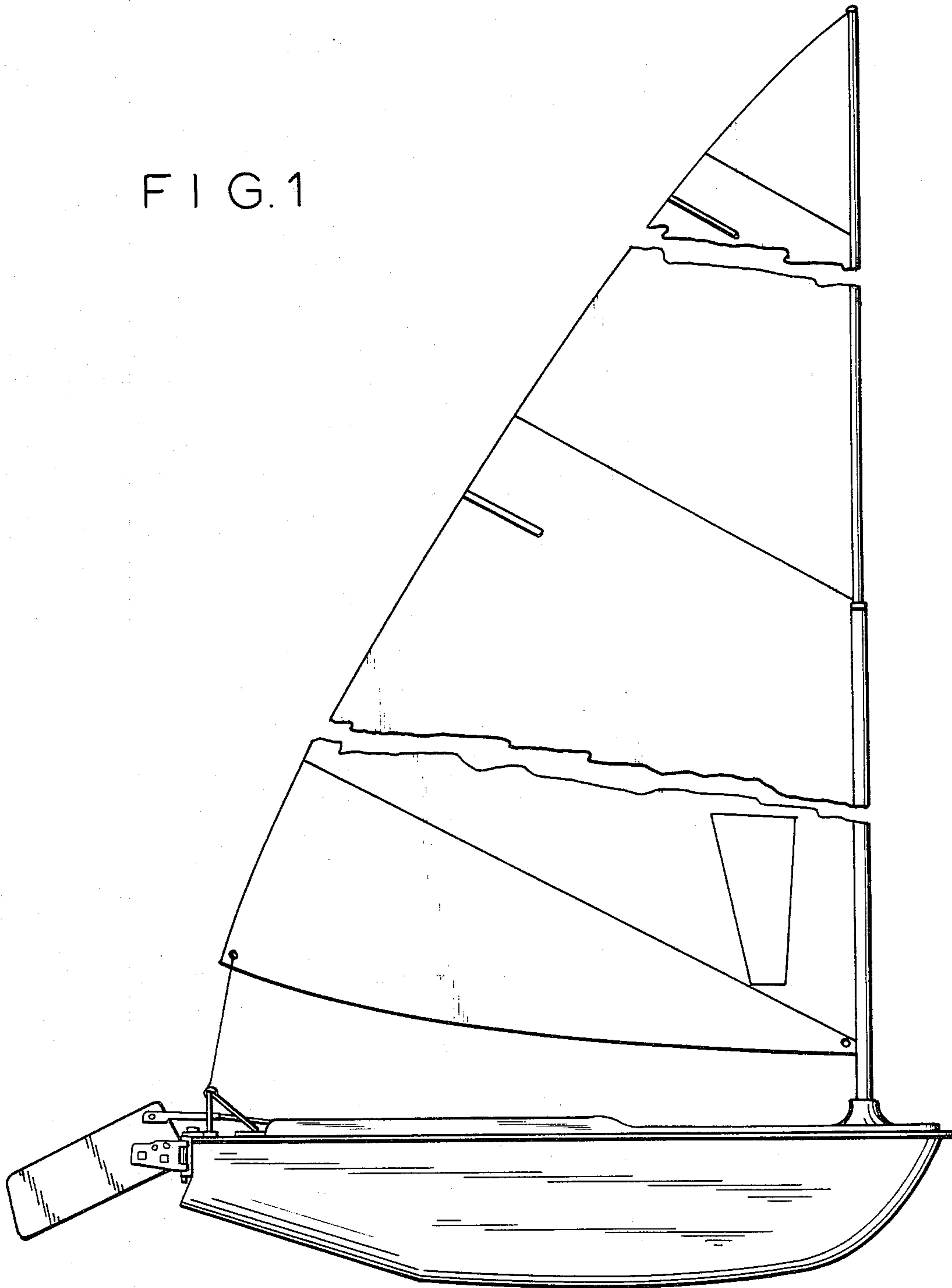

FIG. 2

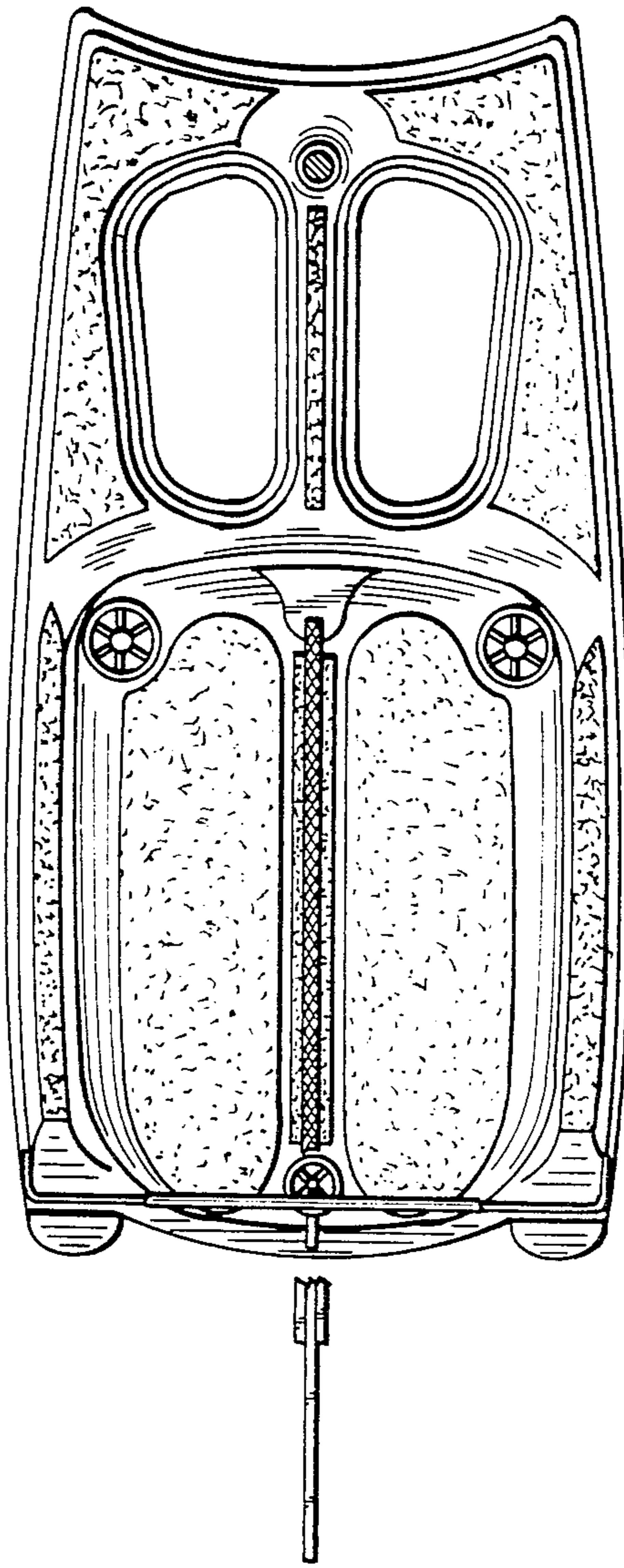

FIG. 3

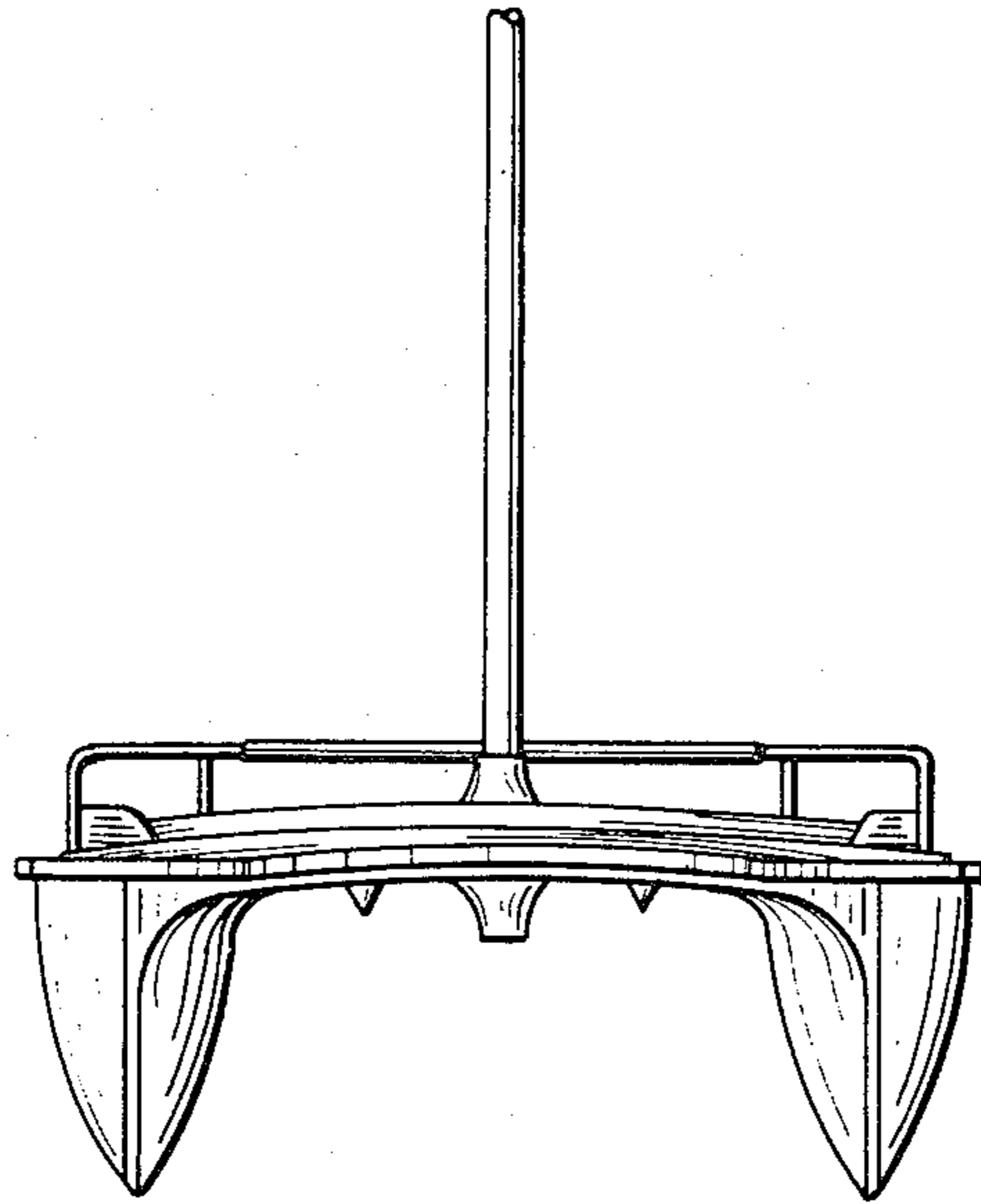

FIG. 4

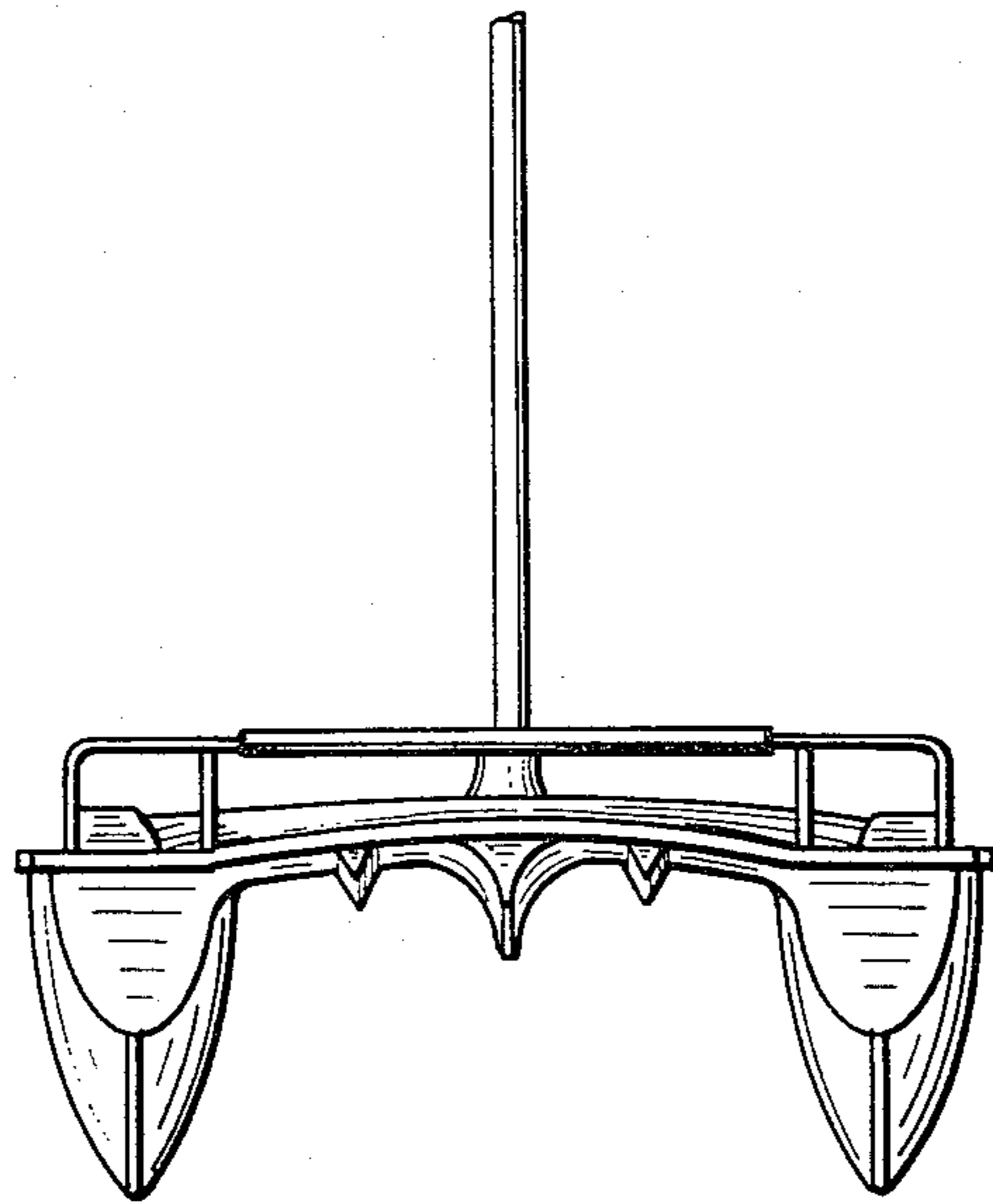

FIG. 5

