

[54] **MOTORBIKE BRAKE ASSEMBLY HOUSING**
[75] Inventor: **Kenneth D. Hurley**, Saginaw, Mich.
[73] Assignee: **Mark E. Burch**, Bay City, Mich. ; a part interest
[**] Term: **14 Years**
[21] Appl. No.: **414,489**
[22] Filed: **Sep. 2, 1982**
[52] U.S. Cl. **D12/126; D12/180**
[58] Field of Search **D12/180, 114, 126; 74/608, 606 R; 180/219**

[56] **References Cited**
U.S. PATENT DOCUMENTS
D. 245,412 8/1977 Ray D12/126
OTHER PUBLICATIONS
Choppers, 11/80, rear cover, Lower Housing Adjacent Bottom Frame Tubes, of Motorcycle.
J. C. Whitney Catalog No. 414B, ©1981, p. 163,

Finned Aluminum Oil Pan, third box down and second column in from right side of page.

Primary Examiner—James M. Gandy
Attorney, Agent, or Firm—John J. Swartz

[57] **CLAIM**

The ornamental design for a motorbike brake assembly housing, as shown.

DESCRIPTION

FIG. 1 is a side elevational view of a motorbike brake assembly housing, showing my new design;
FIG. 2 is a top plan view thereof;
FIG. 3 is a bottom plan view thereof;
FIG. 4 is an end elevational view, taken along the line 4—4 of FIG. 1;
FIG. 5 is an opposite end elevational view, taken along the line 5—5 of FIG. 1;
FIG. 6 is an opposite side elevational view thereof; and
FIG. 7 is a perspective view thereof on a reduced scale.

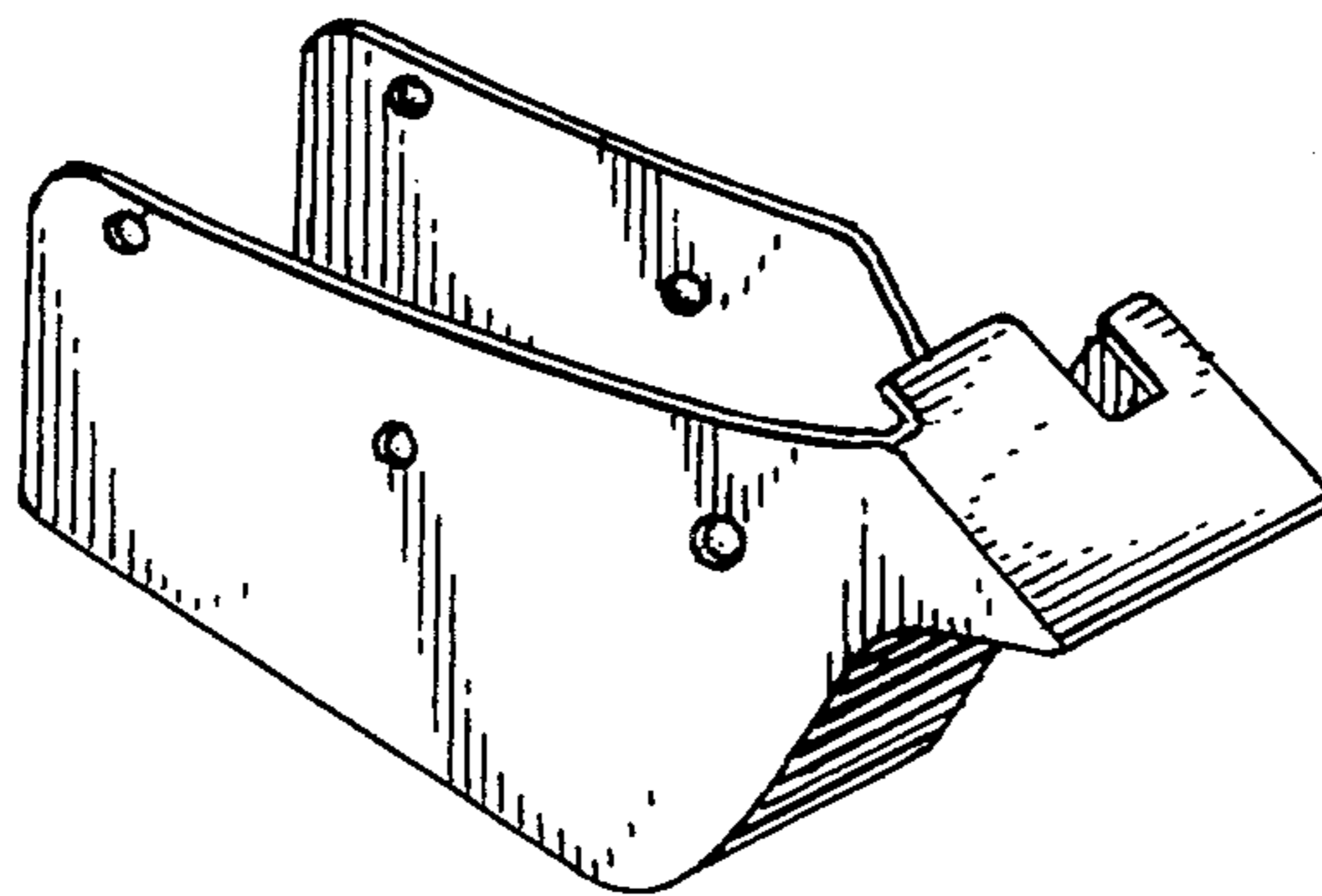

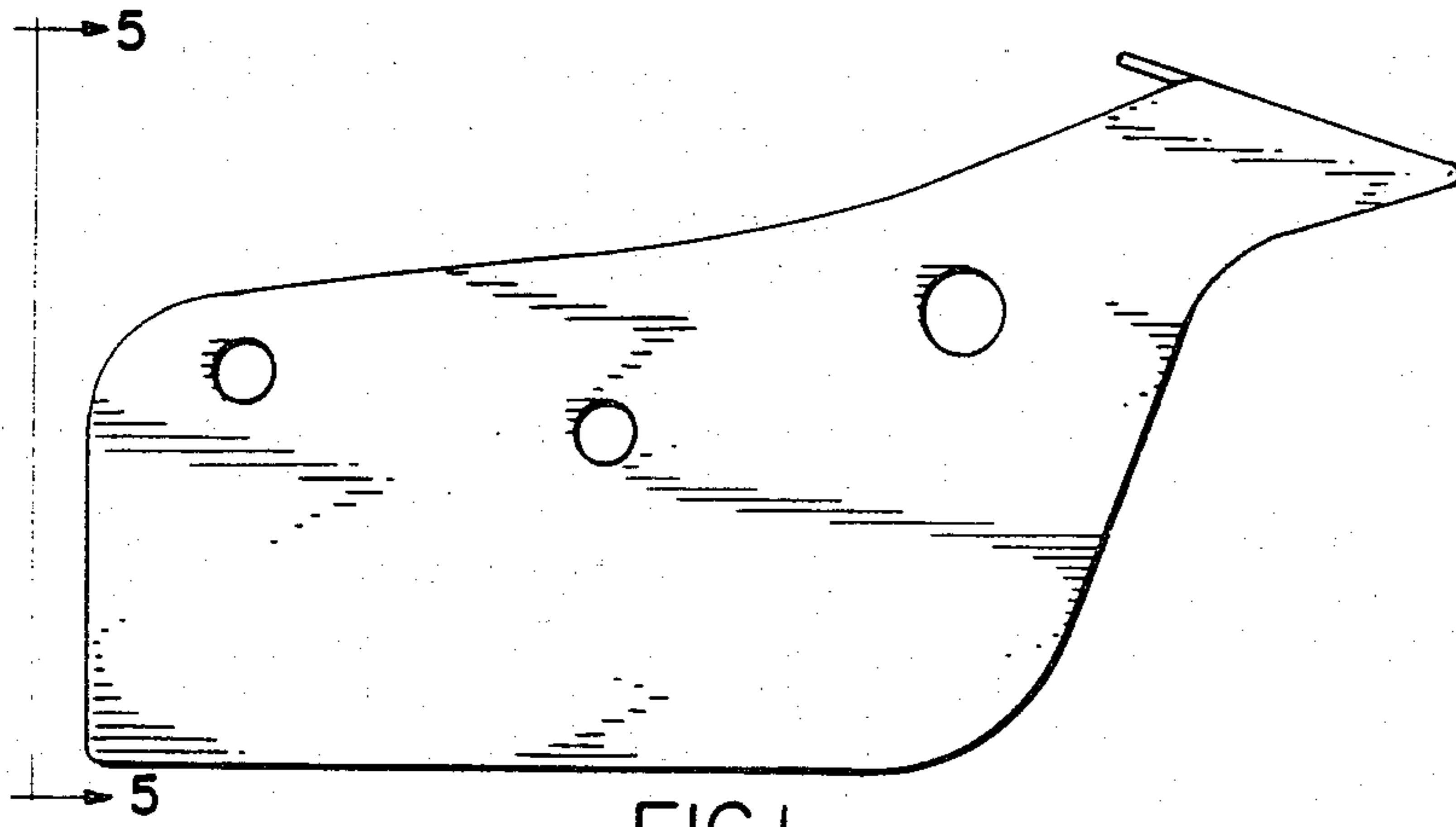

FIG. 1

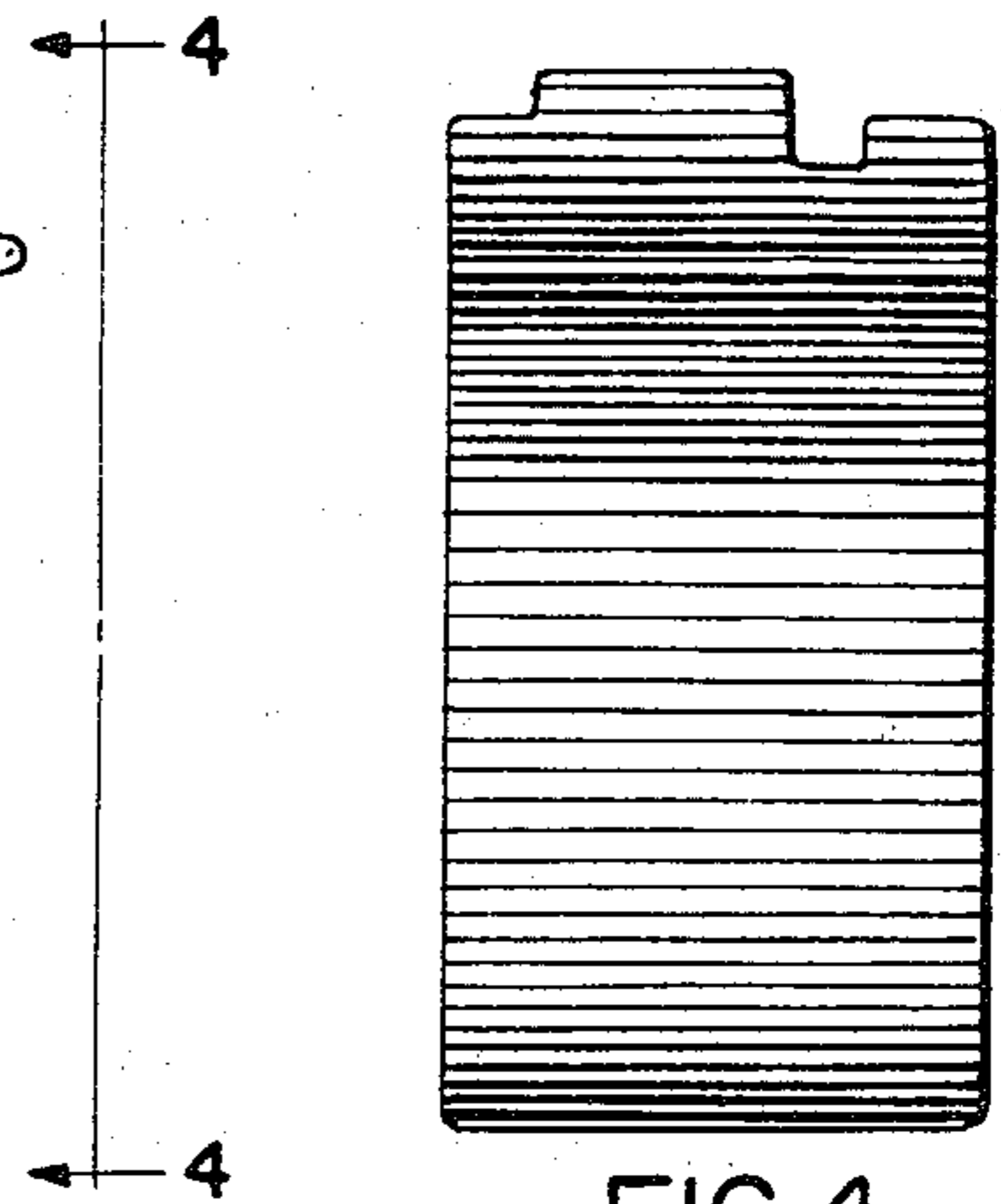

FIG. 4

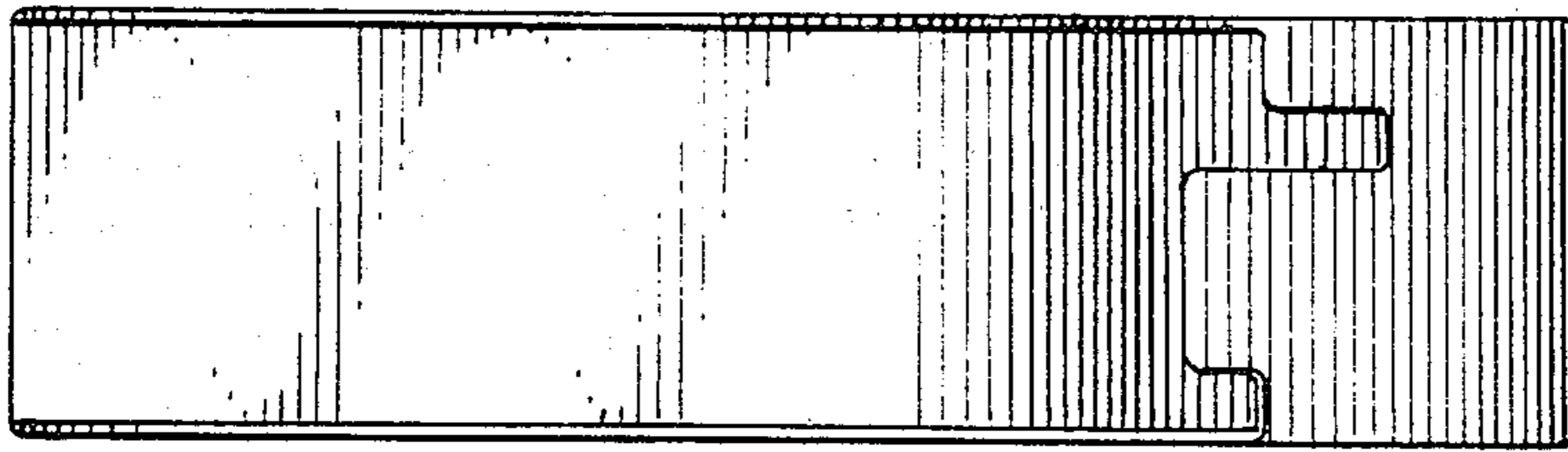

FIG. 2

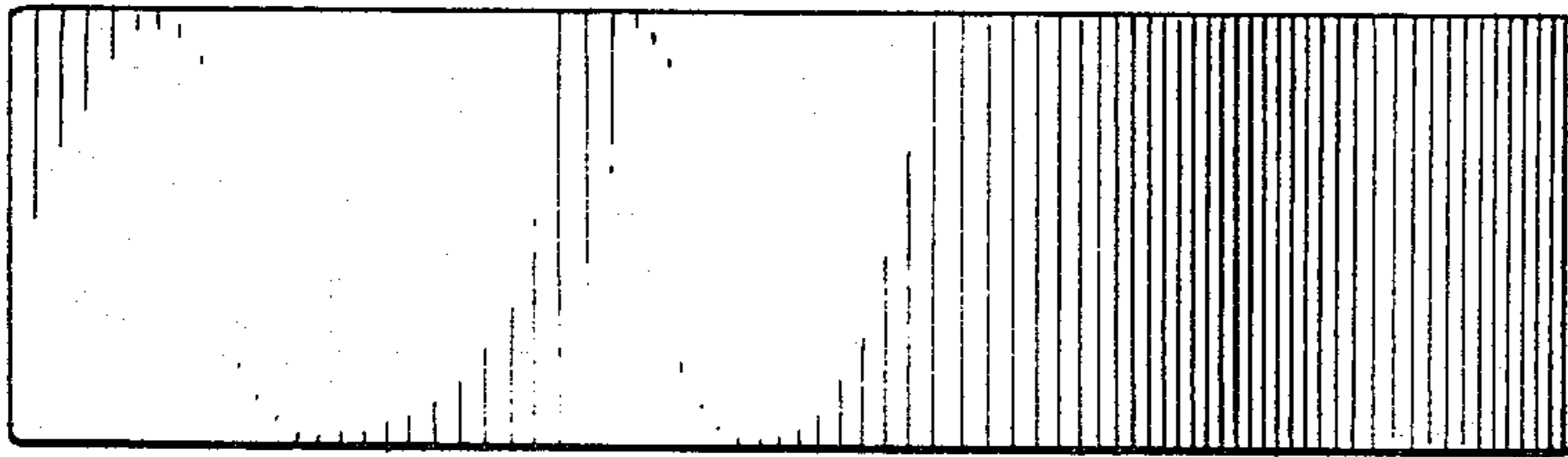

FIG. 3

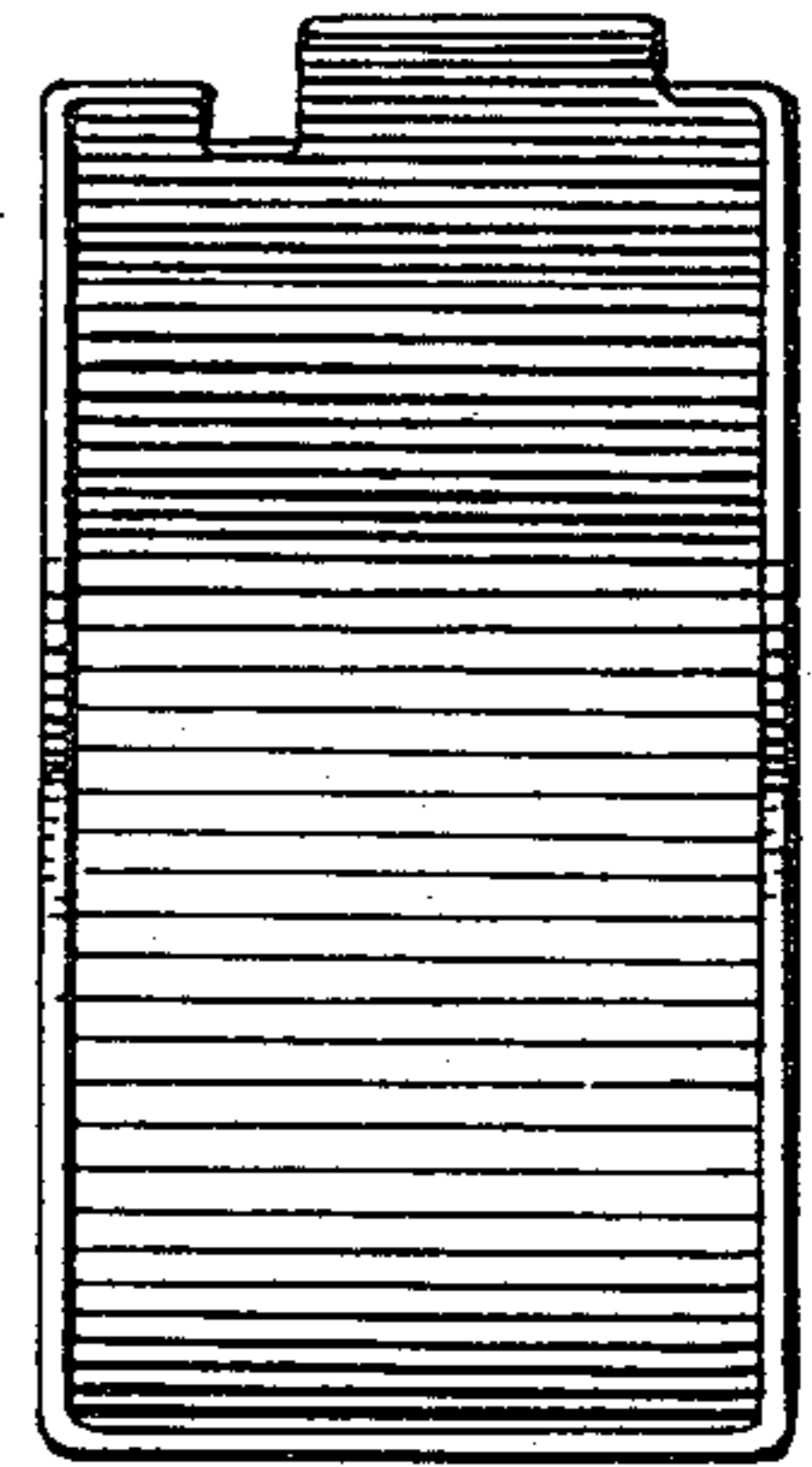

FIG. 5

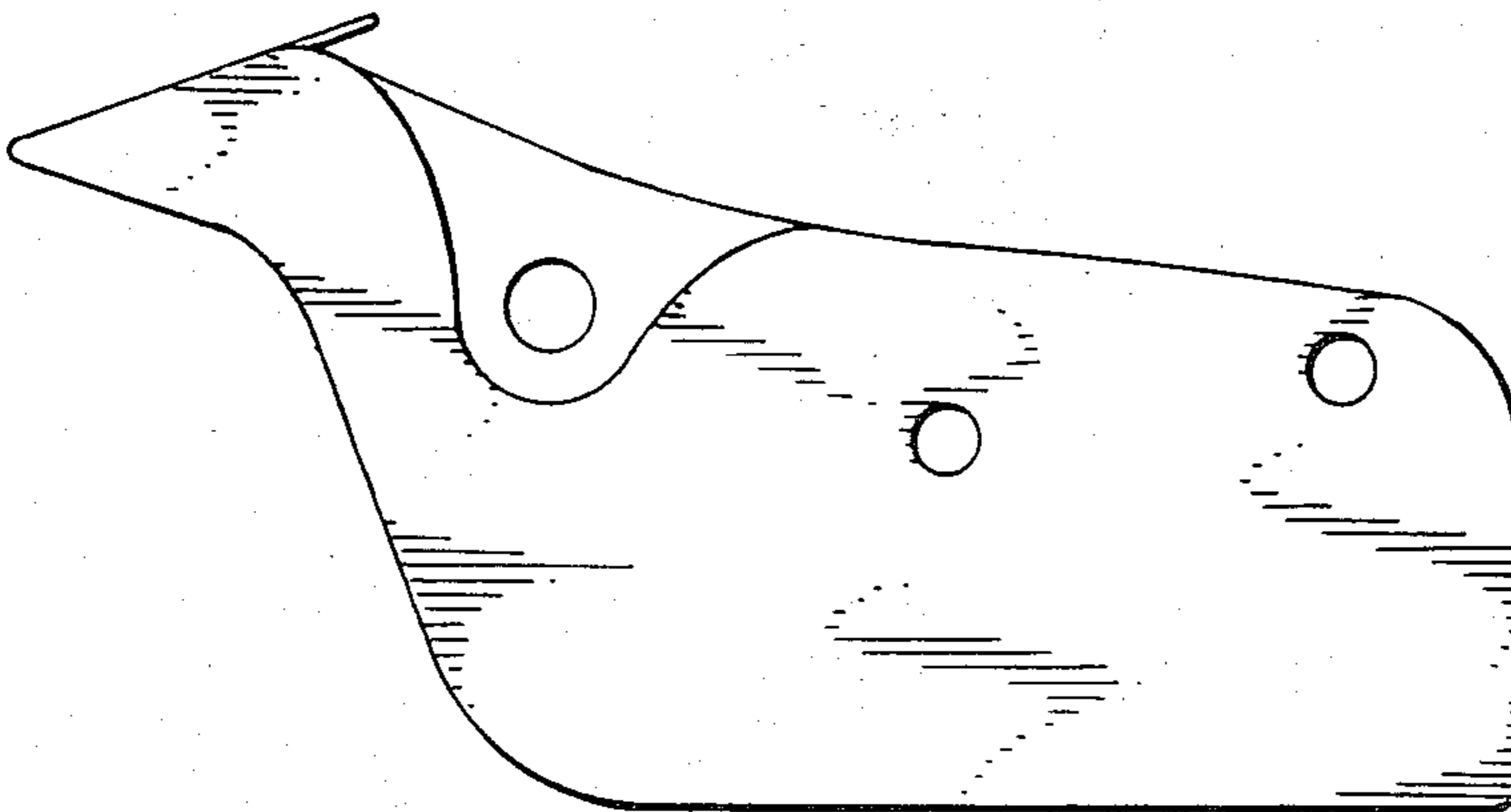

FIG. 6

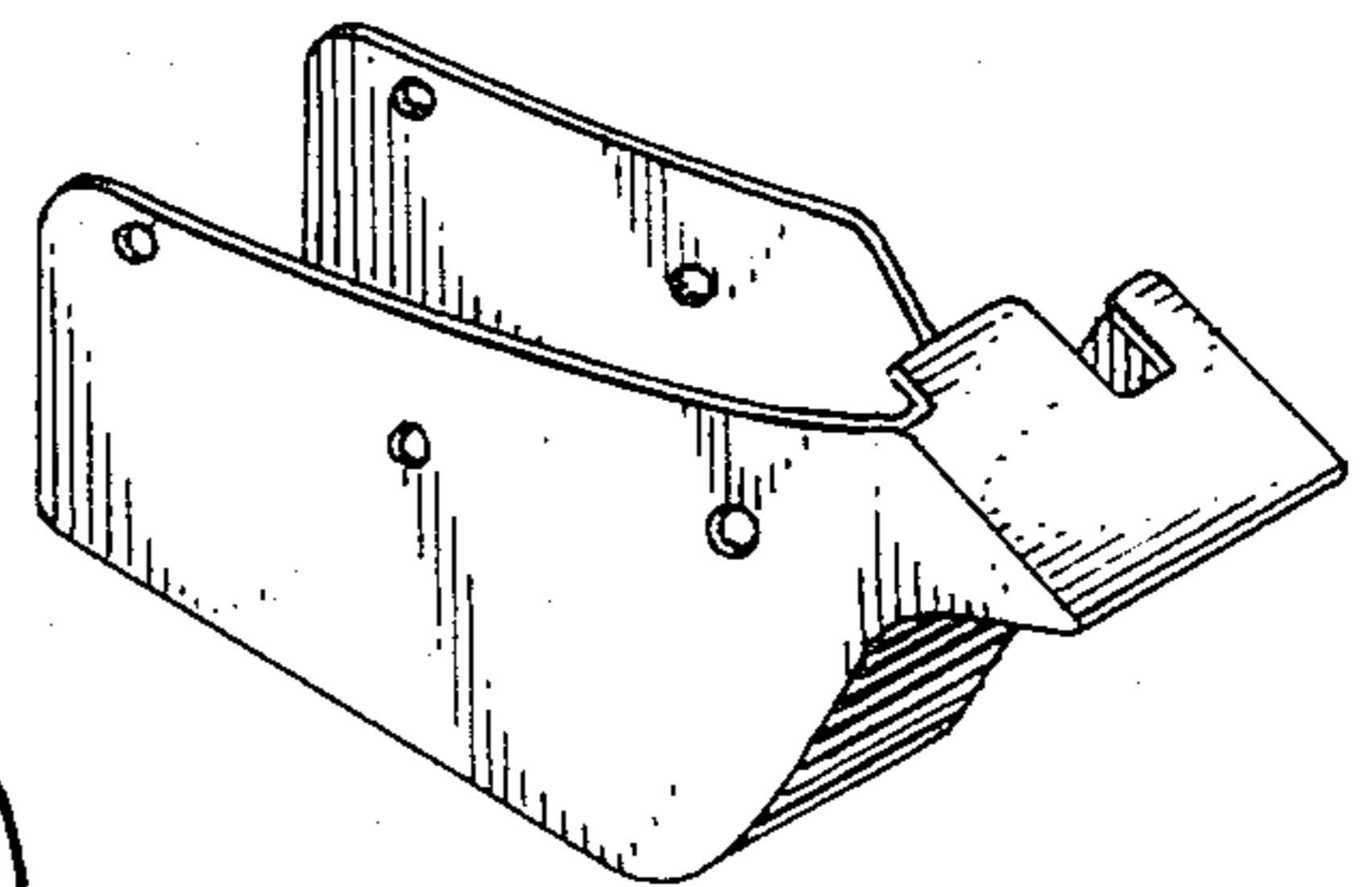

FIG. 7