

[54] **OUTBOARD MOTOR SUPPORT**
[76] **Inventor: James C. Gilbreath, 26225 Big Pines Hwy., P.O. Box 304, Wrightwood, Calif. 92397**
[**] **Term: 14 Years**
[21] **Appl. No.: 417,388**
[22] **Filed: Sep. 13, 1982**
[52] **U.S. Cl. D12/317; D15/4**
[58] **Field of Search D12/317; D15/4; 248/640, 641**

3,877,667 4/1975 Monckton 248/641

Primary Examiner—James M. Gandy
Attorney, Agent, or Firm—Fred N. Schwend

[57] **CLAIM**

The ornamental design for an outboard motor support, as shown and described.

DESCRIPTION

FIG. 1 is a rear perspective view of an outboard motor support showing my new design.
FIG. 2 is a right side elevation view thereof, the left side elevation being a mirror image of said right side view.
FIG. 3 is a rear elevation view thereof.
FIG. 4 is a front elevation view thereof.
FIG. 5 is a top plan view thereof.
FIG. 6 is a bottom plan view thereof.

[56] **References Cited**
U.S. PATENT DOCUMENTS
3,032,304 5/1962 Machlan 248/641
3,245,641 4/1966 Hart 248/641

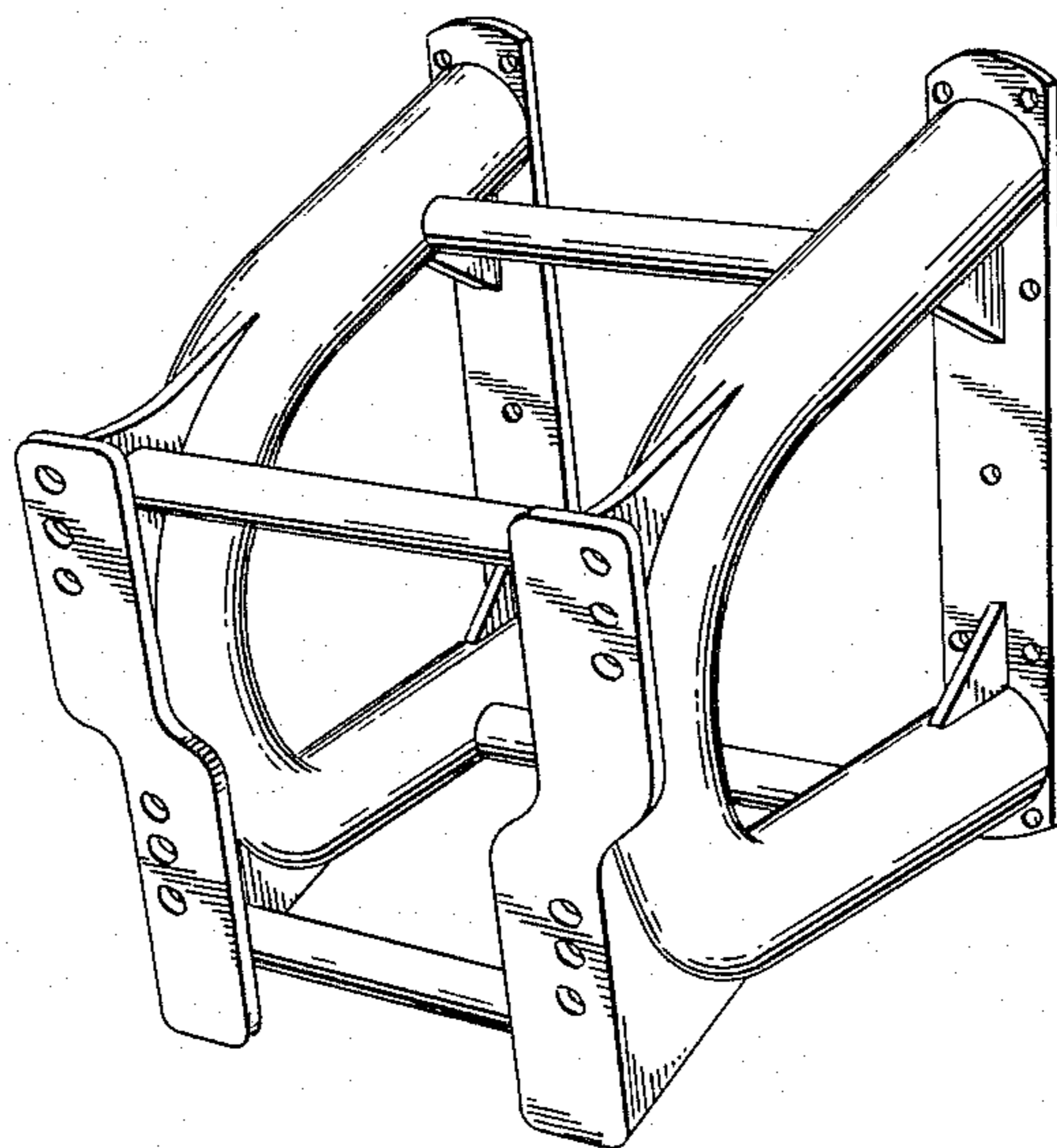

FIG. 1.

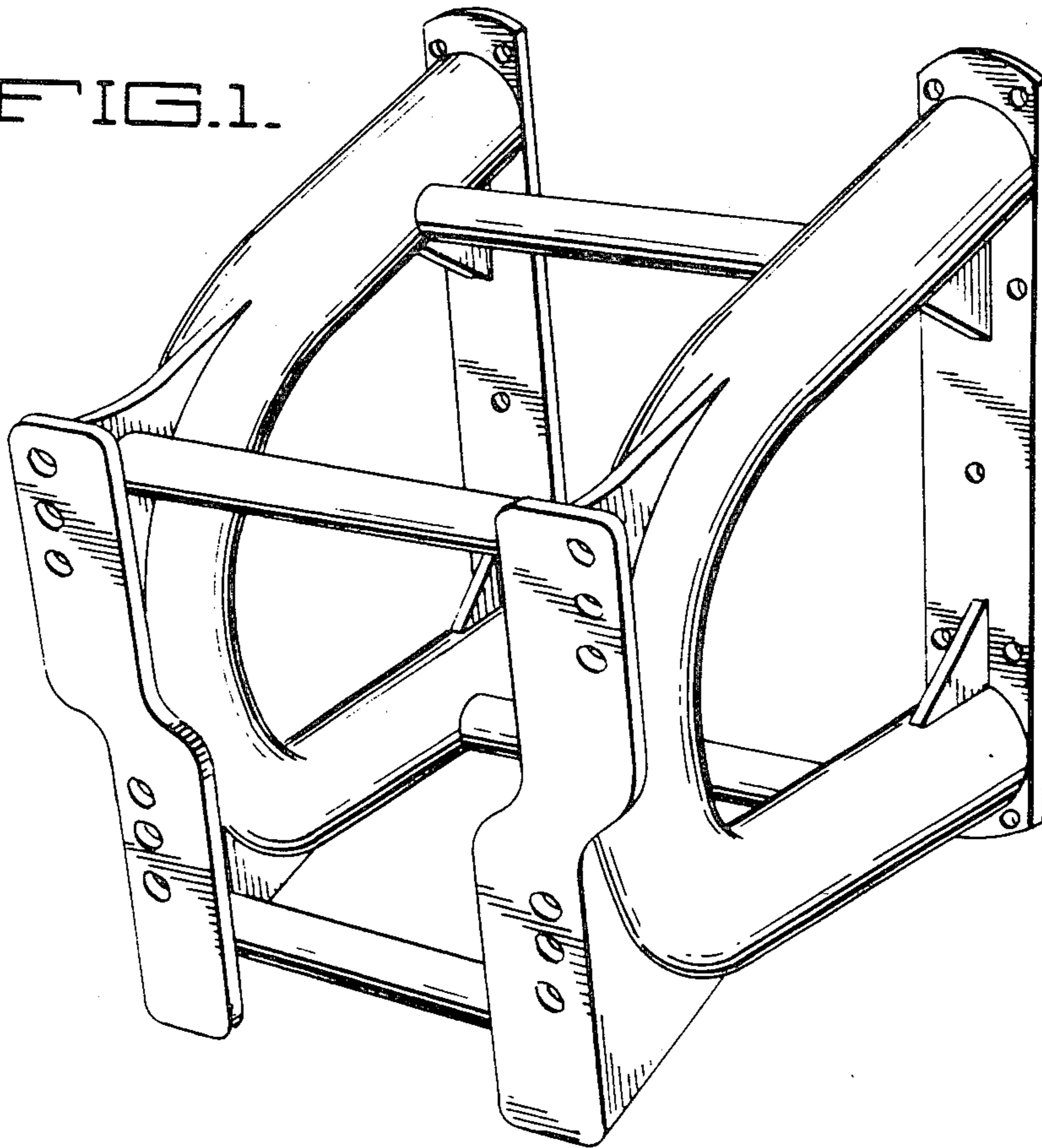

FIG. 2.

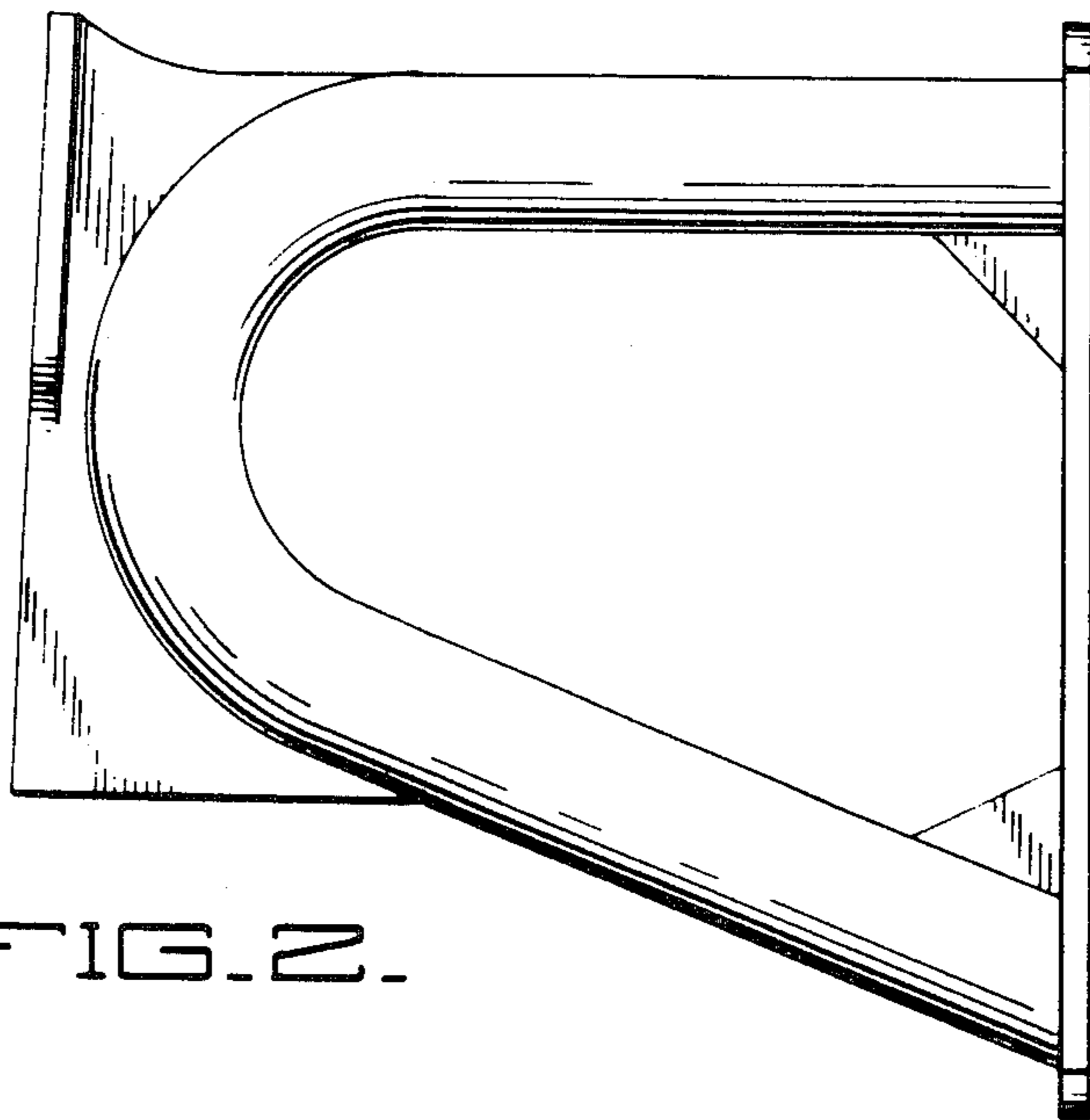

FIG. 3.

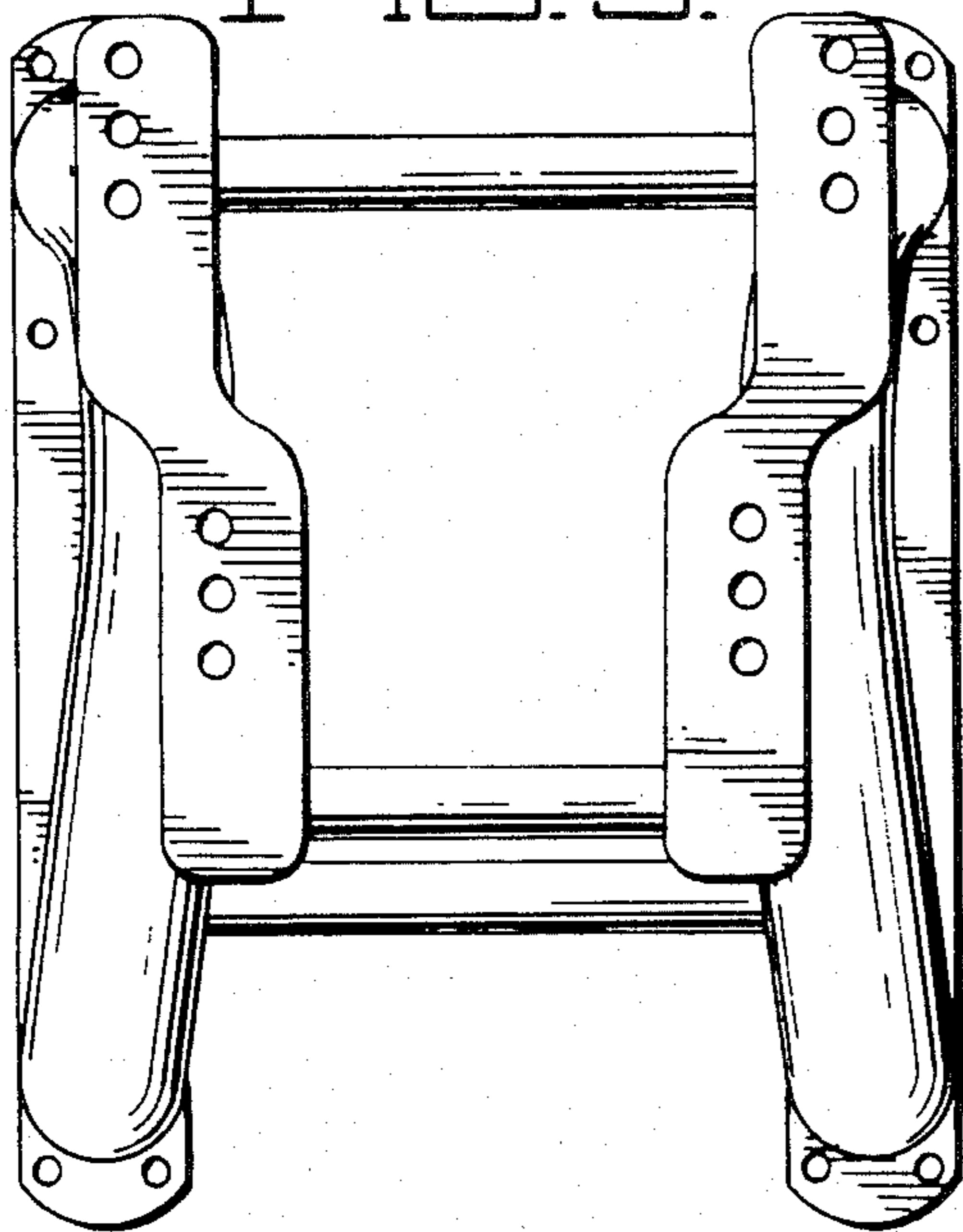

FIG. 4.

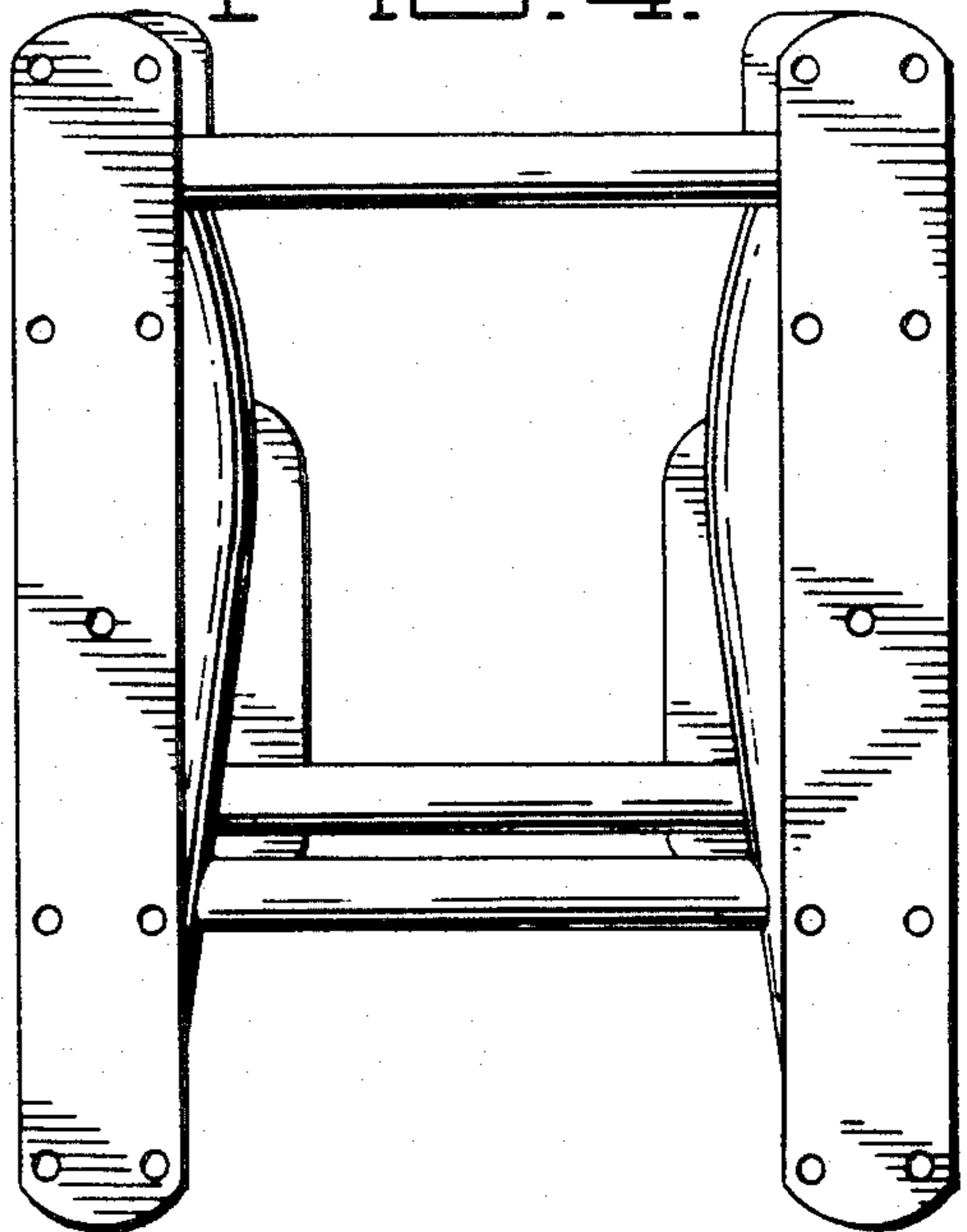

FIG. 5.

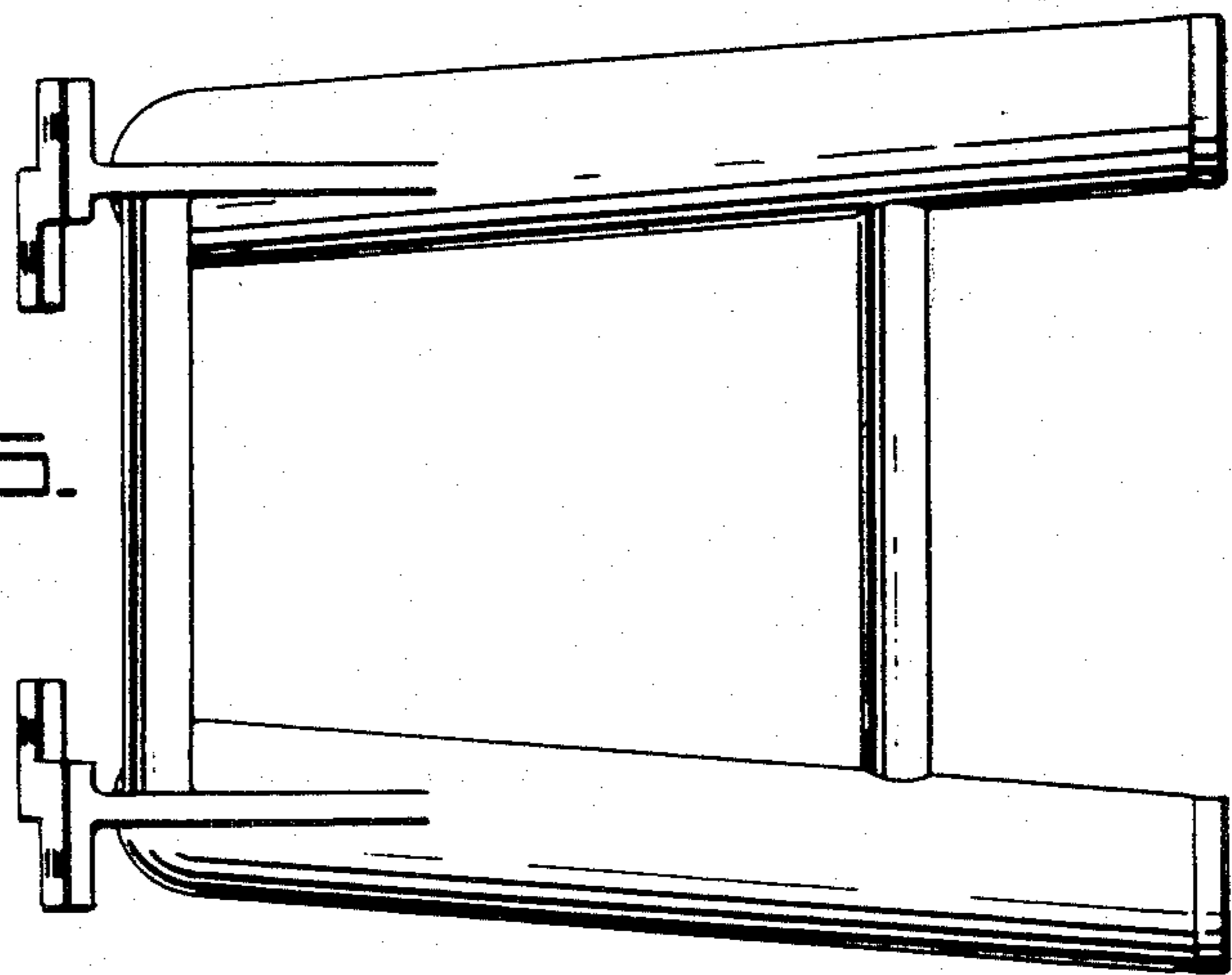

FIG. 6.

