

[54] **VEHICLE WHEEL CENTER**

[76] Inventor: **Raymond J. Hedlund**, 1250 Pinecreek Way, Concord, Calif. 94520

[**] Term: **14 Years**

[21] Appl. No.: **448,156**

[22] Filed: **Dec. 9, 1982**

[52] U.S. Cl. **D12/211**

[58] Field of Search **D12/209, 211, 210, 135; 301/63 R, 64 R, 64 SD, 65, 66**

[56] **References Cited**

U.S. PATENT DOCUMENTS

D. 85,952	1/1932	Miller	D12/135
D. 204,256	4/1966	Rader	D12/211
D. 204,669	5/1966	Goodwin	D12/209
D. 206,432	12/1966	Reid	D12/209
D. 213,314	2/1969	Reid	D12/209
D. 231,732	6/1974	Ishibashi	D12/209
D. 258,876	4/1981	Main	D12/210

OTHER PUBLICATIONS

American Bicyclist & Motorcyclist, 4/81, p. 93, Sprocket Wheel, center of page.

Primary Examiner—James M. Gandy

Attorney, Agent, or Firm—Ralph J. Skinkiss; David L. Kuhn

[57] **CLAIM**

The ornamental design for a vehicle wheel center, substantially as shown and described.

DESCRIPTION

FIG. 1 is a left, front perspective view of a vehicle wheel center showing my new design, it being understood that the broken lines are for illustrative purposes only.

FIG. 2 is a front elevational view thereof.

FIG. 3 is a sectional view taken along line 3—3 in FIG. 2 it being understood that the bolt and nut assemblies have not been shown in section for ease of illustration.

FIG. 4 is a sectional view taken along line 4—4 in FIG. 2.

FIG. 5 is a sectional view taken along line 5—5 in FIG. 2.

FIG. 6 is a sectional view taken along line 6—6 in FIG. 2.

FIG. 7 is a front perspective view of a vehicle wheel center showing a second embodiment of my new design, the difference being that this embodiment features a six spoke center whereas FIG. 1 shows a five spoke center.

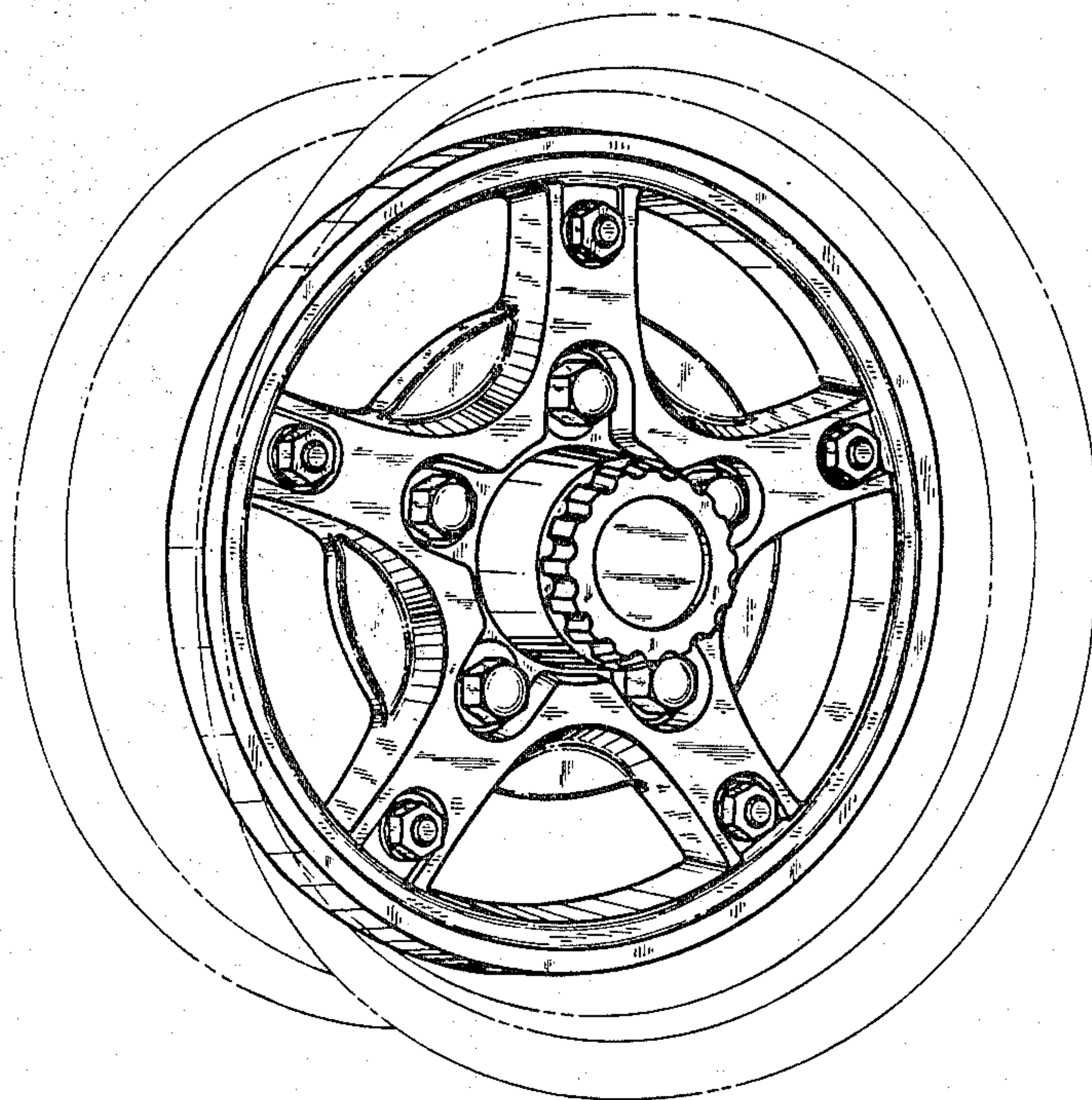

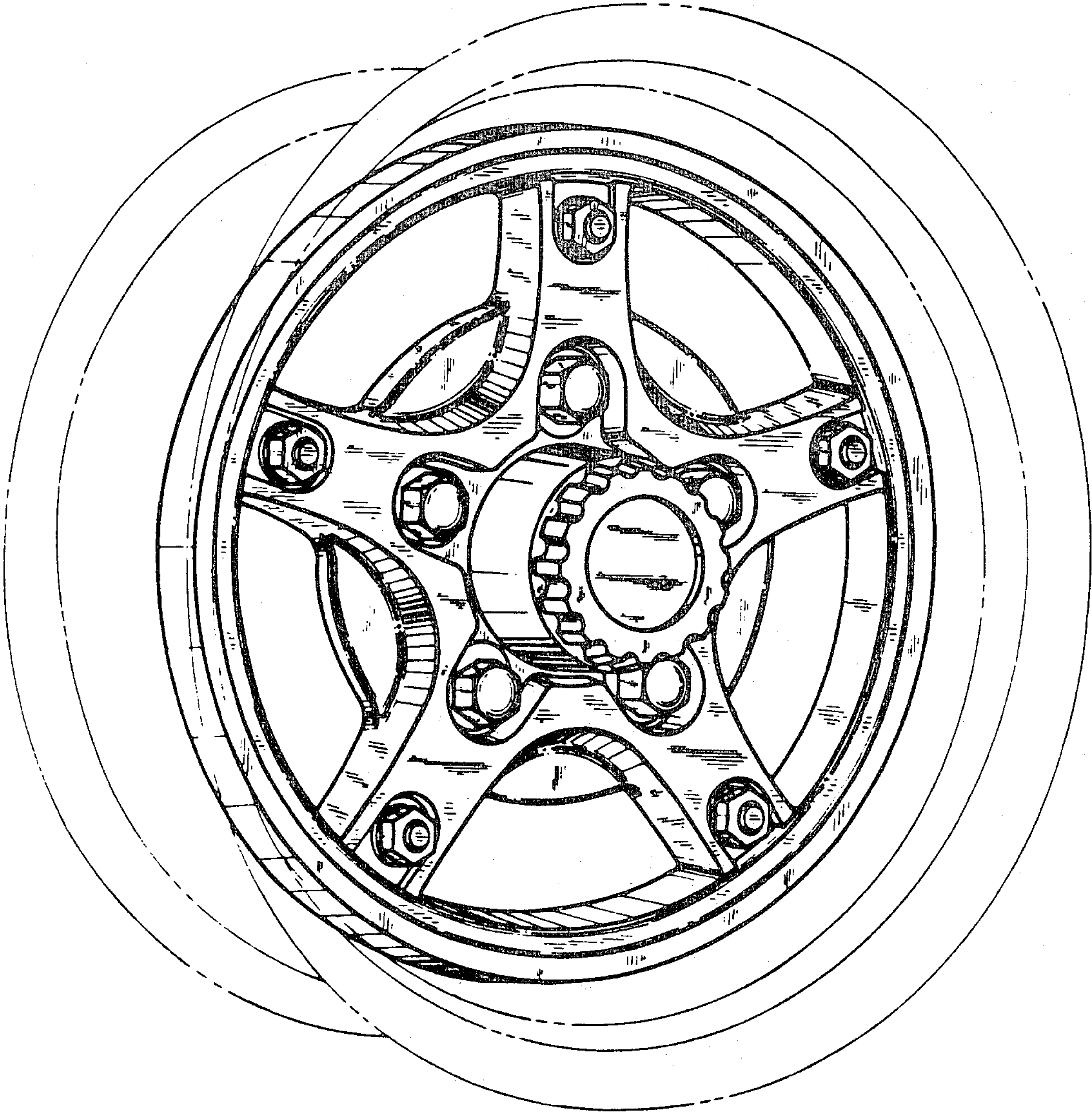

—FIG. 1

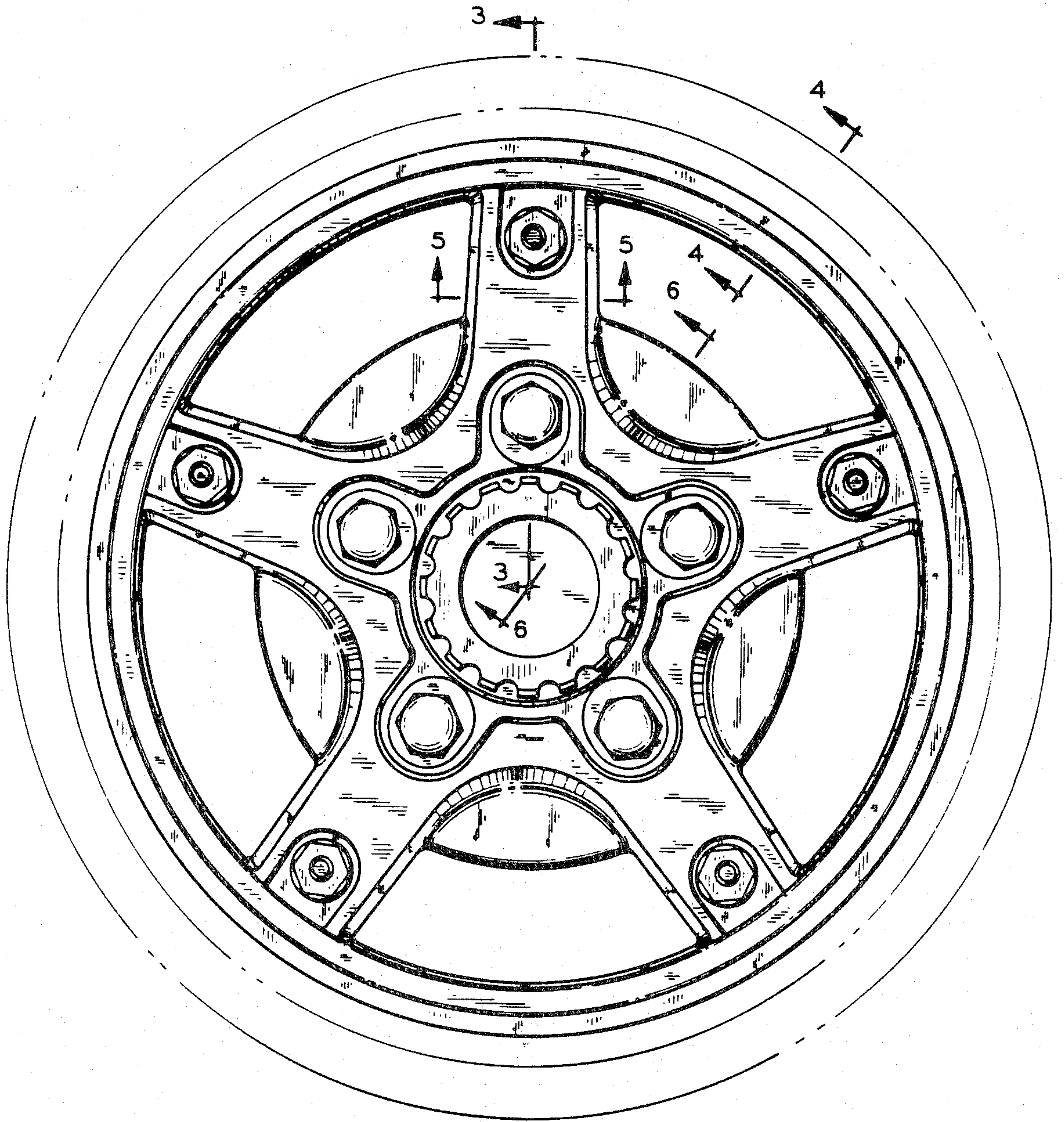
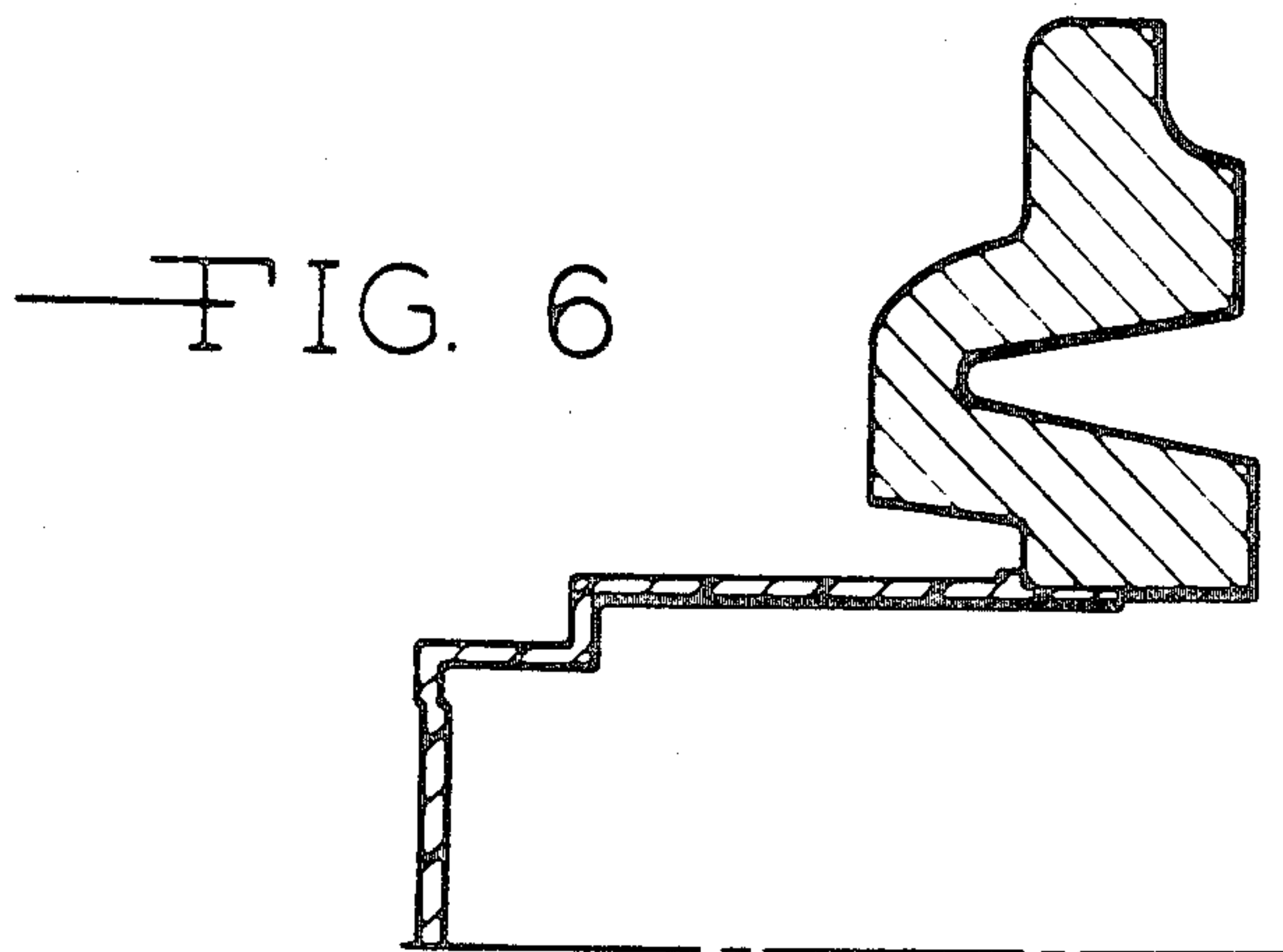
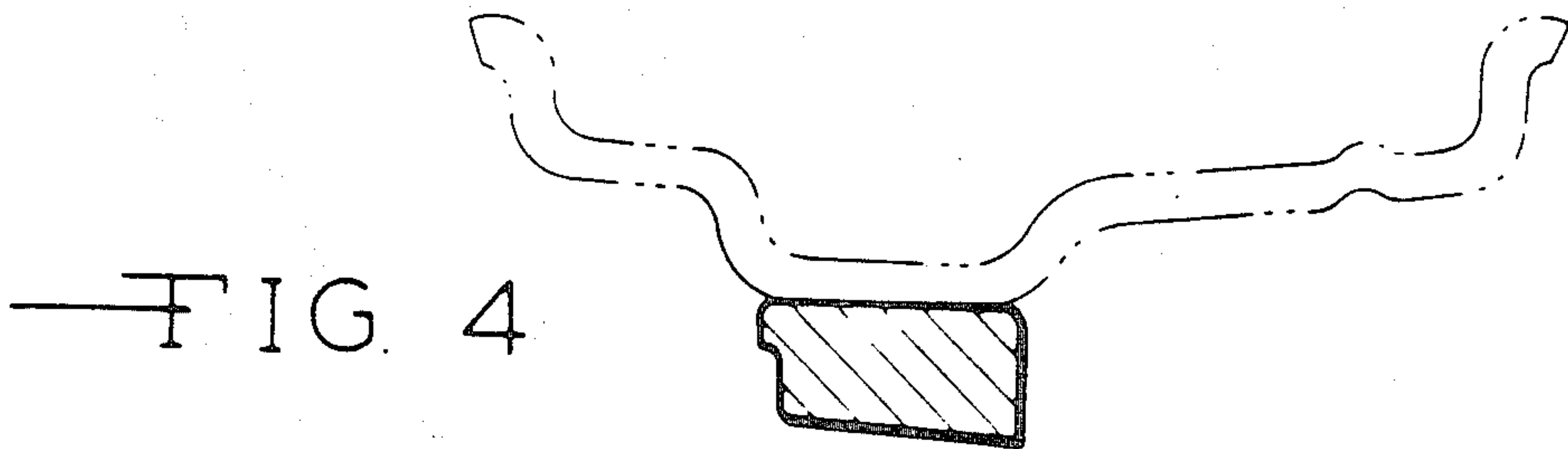
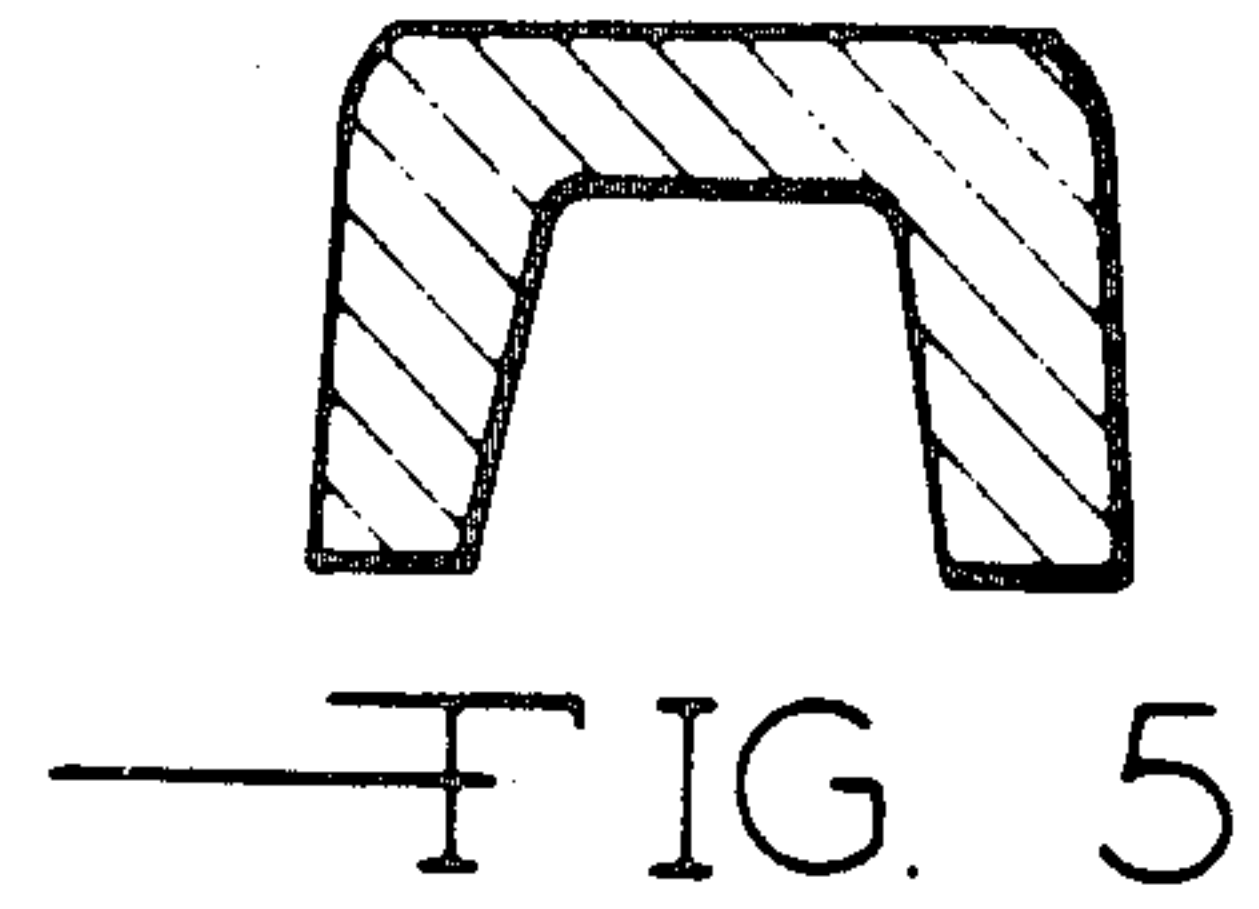
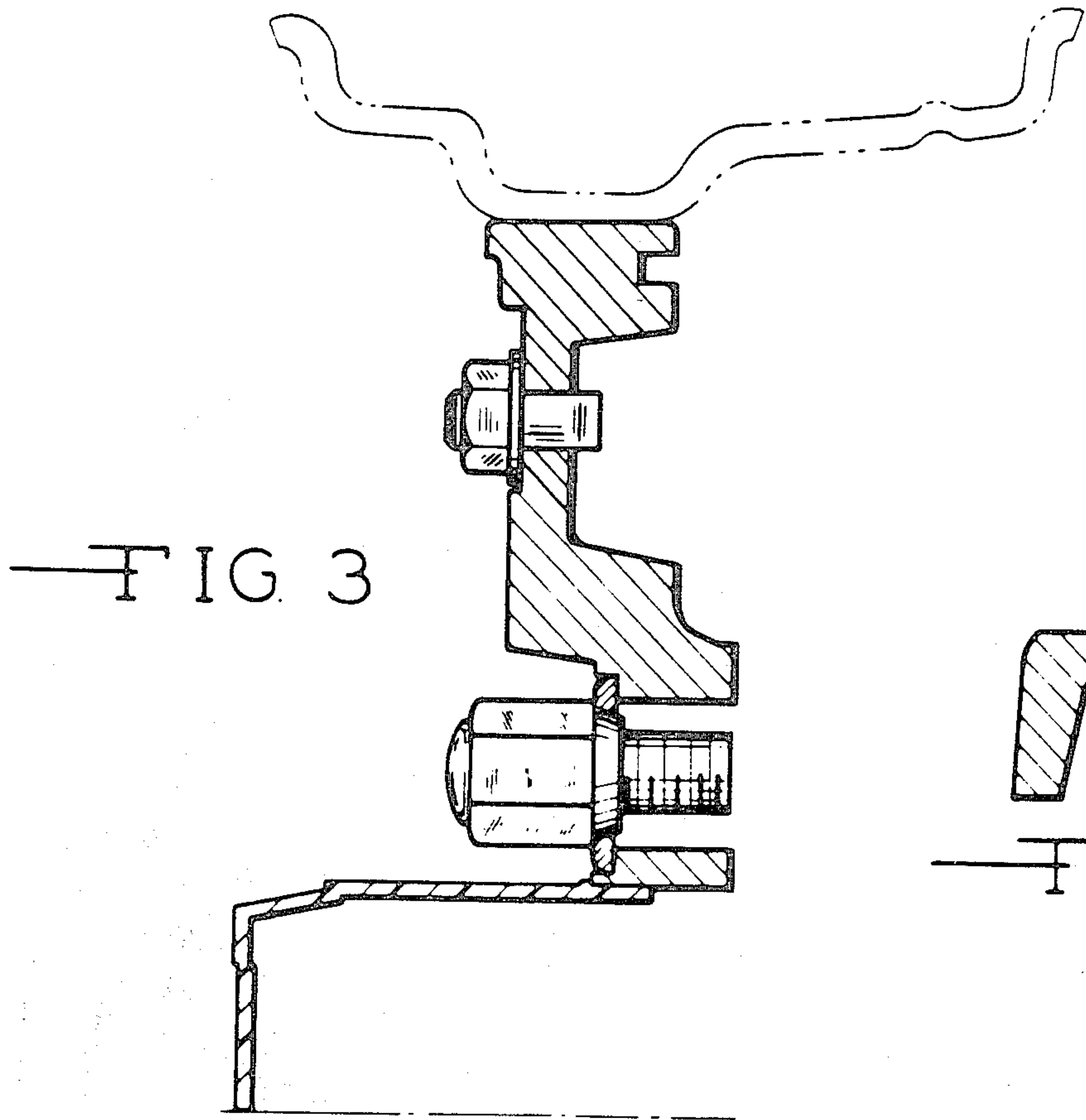
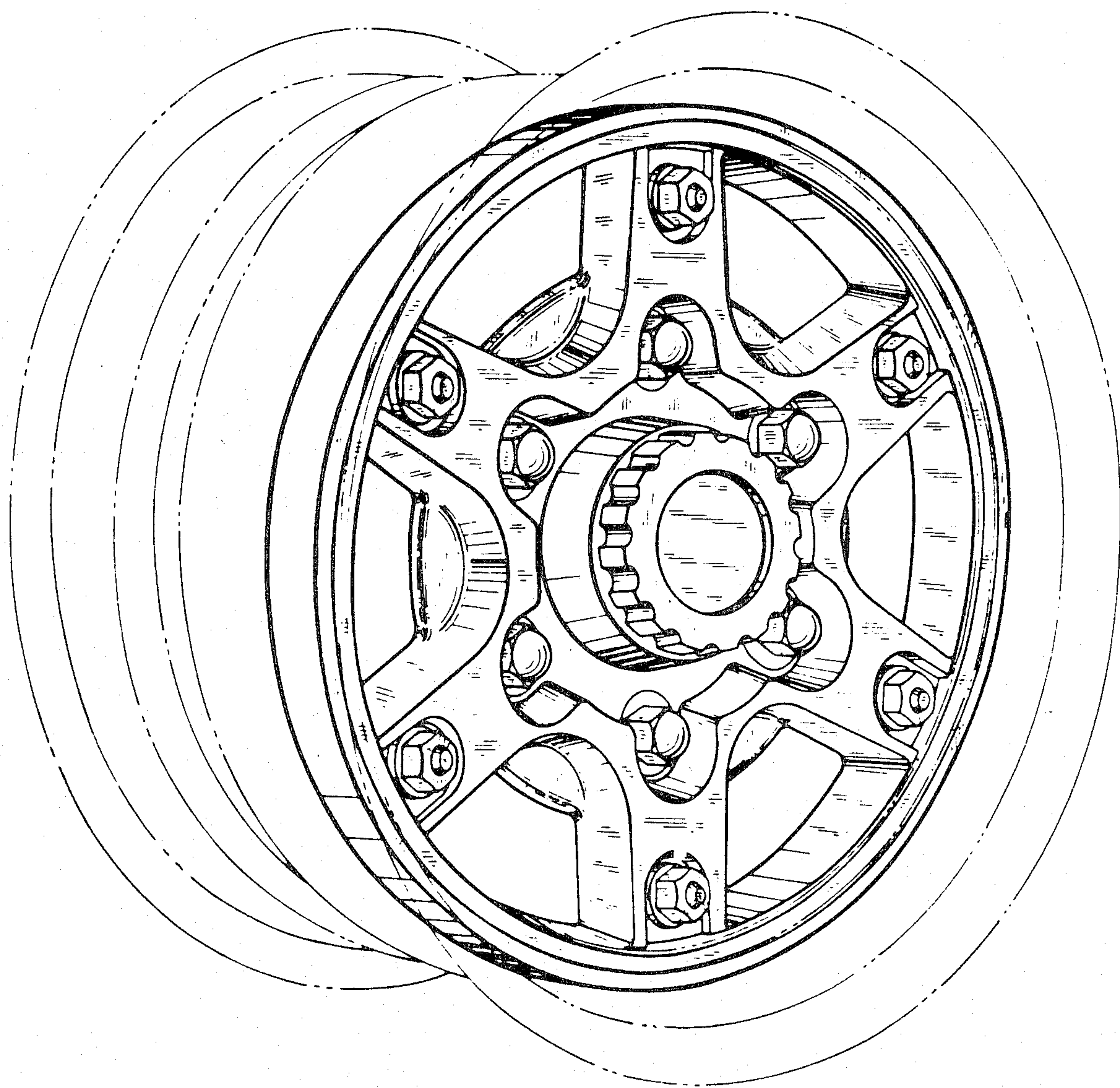

FIG. 2





—FIG. 7