

[54] MOTORCYCLE ENGINE

[75] Inventor: William G. Davidson, Elm Grove, Wis.

[73] Assignee: Harley-Davidson Motor Co., Inc, Milwaukee, Wis.

[**] Term: 14 Years

[21] Appl. No.: 428,284

[22] Filed: Sep. 29, 1982

[52] U.S. Cl. D15/1; D15/3

[58] Field of Search D15/1, 3, 5; D12/10, D12/14

[56] References Cited

U.S. PATENT DOCUMENTS

- D. 134,742 1/1943 Redlund D12/114
- D. 214,539 6/1969 Fullerton D15/1
- D. 255,353 6/1980 Ullrich D15/5

- D. 267,245 12/1982 Iwasaki D12/110
- D. 267,638 1/1983 Iwasaki D12/110

OTHER PUBLICATIONS

Jane's All the World's Aircraft 1965-1966 p. 487 100 hp Rolls Royce/Continental.

Primary Examiner—A. Hugo Word

Assistant Examiner—Lynn Wilder

[57] CLAIM

The ornamental design for a motorcycle engine, as shown.

DESCRIPTION

FIG. 1 is a right side elevational view of a motorcycle engine showing my new design;

FIG. 2 is a left side elevational view thereof;

FIG. 3 is a rear elevational view thereof;

FIG. 4 is a front elevational view thereof; and

FIG. 5 is a top plan view thereof.

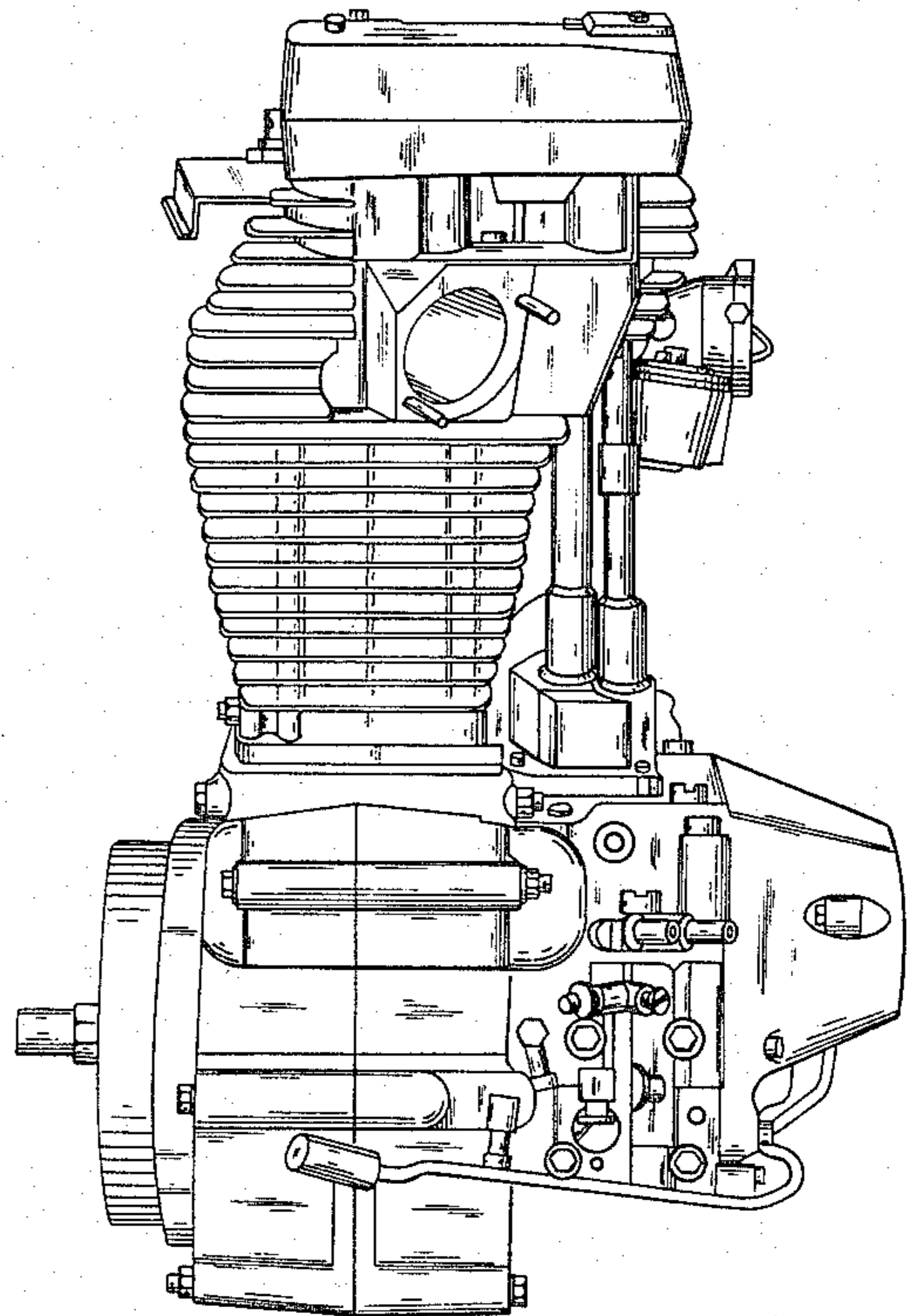
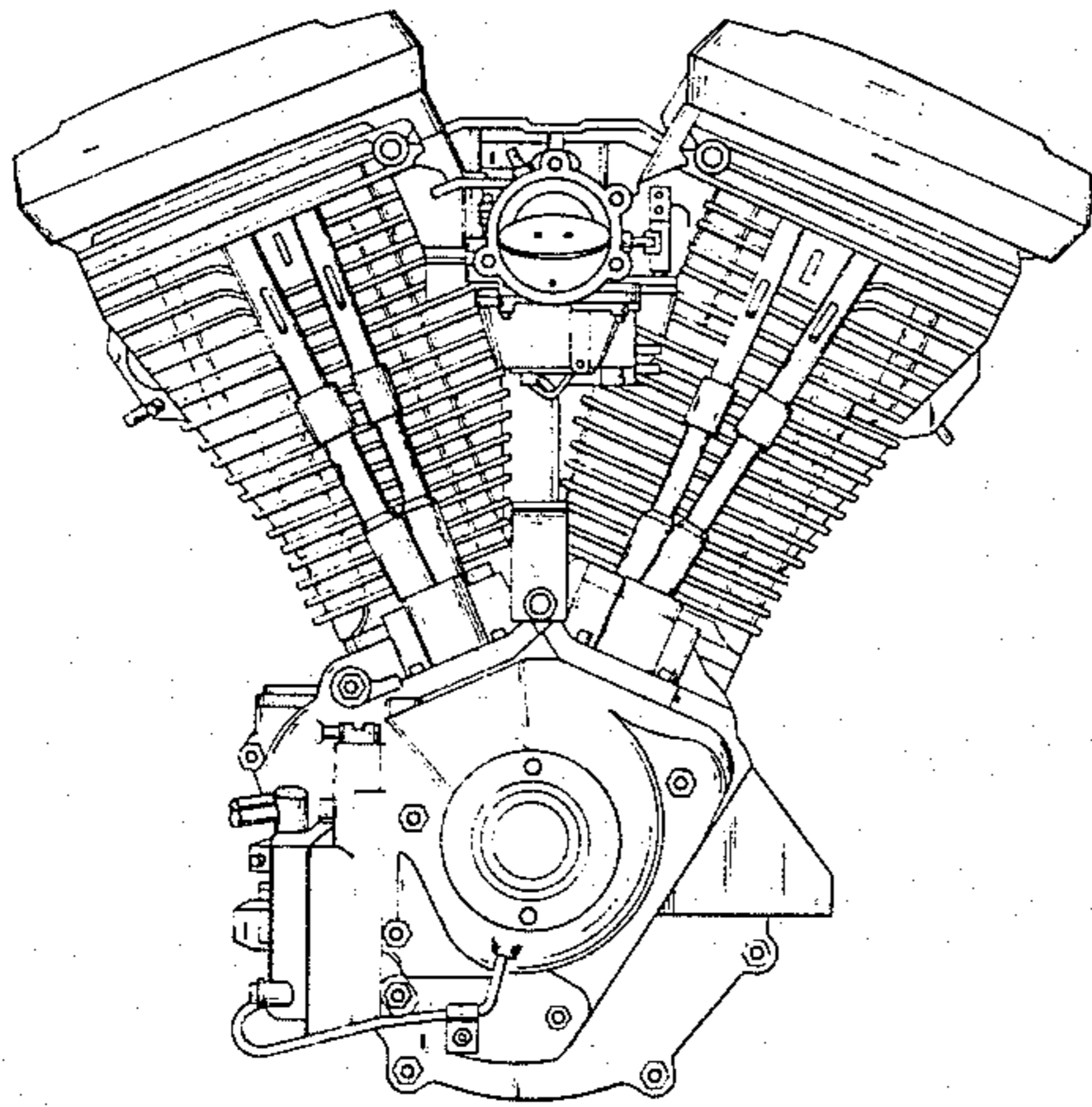

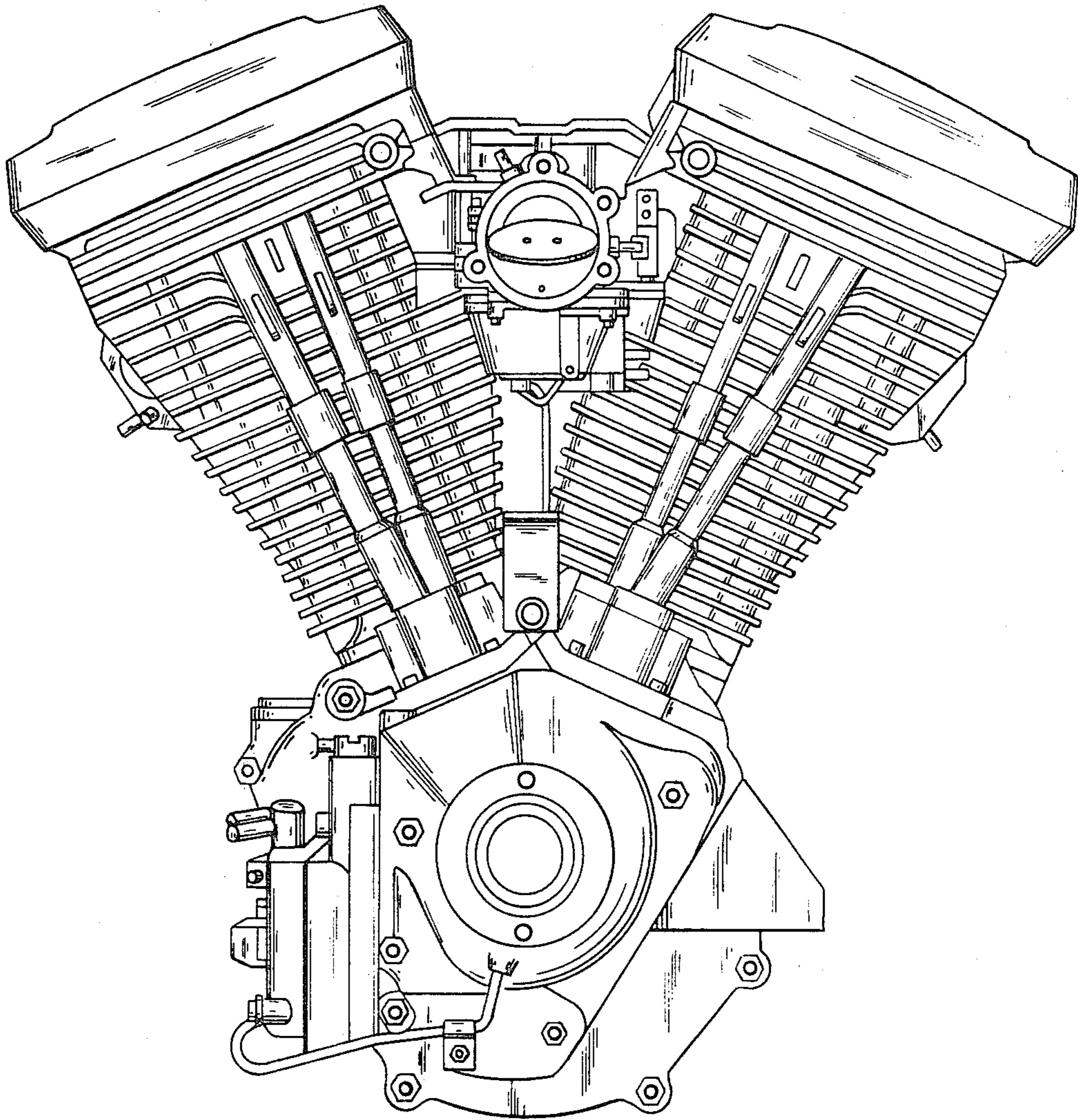

FIG. 1

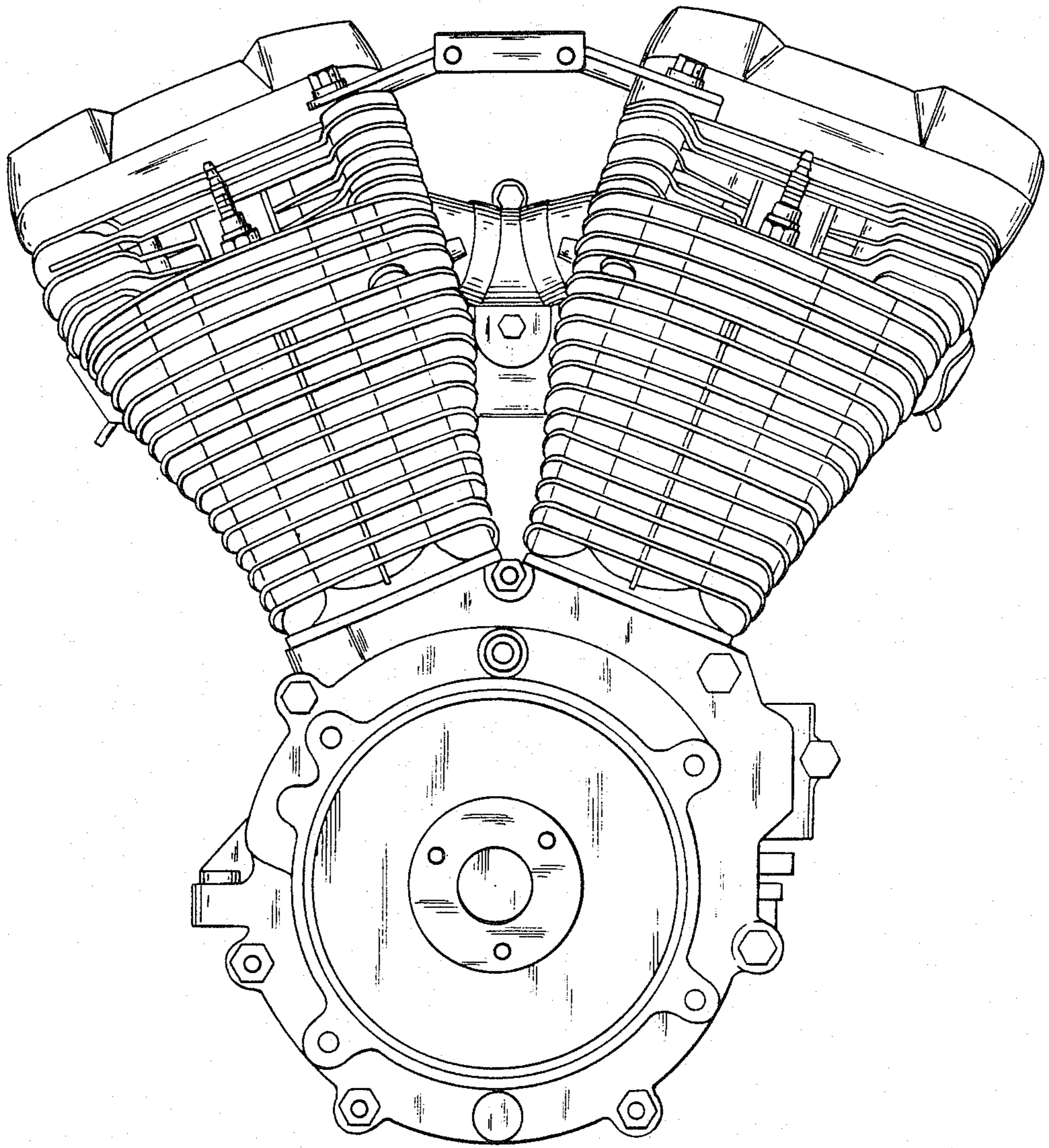

FIG. 2

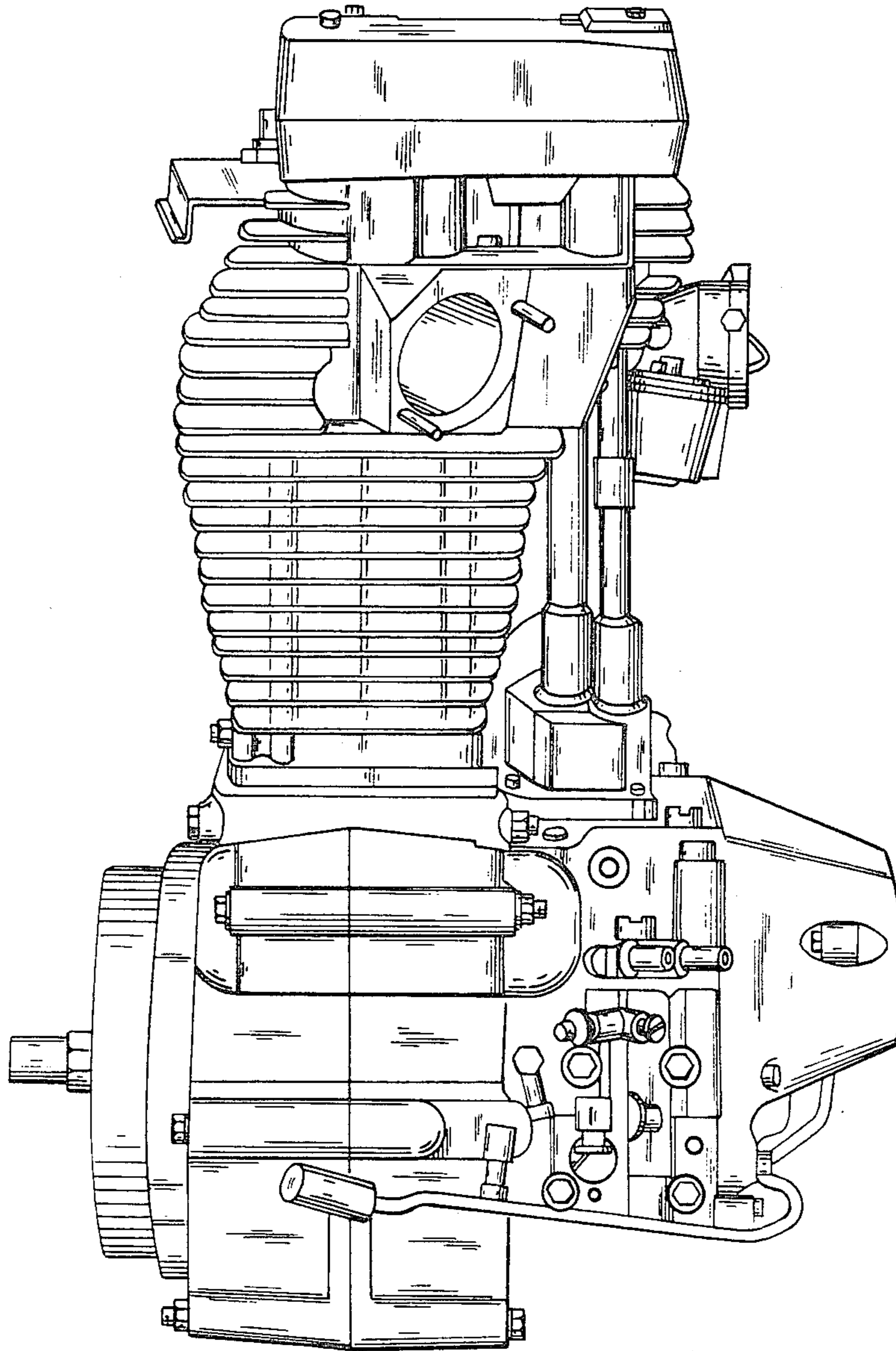

FIG. 3

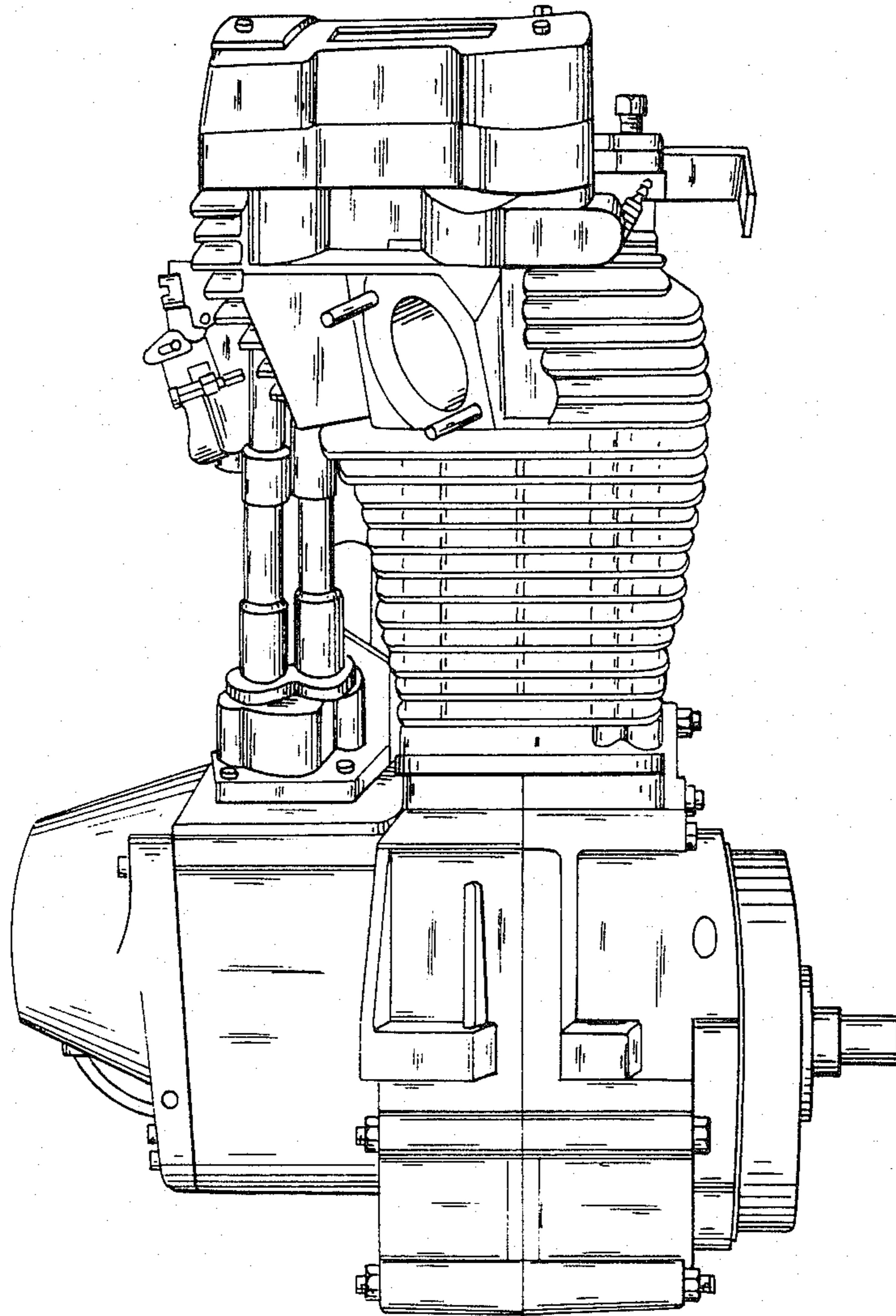

FIG. 4

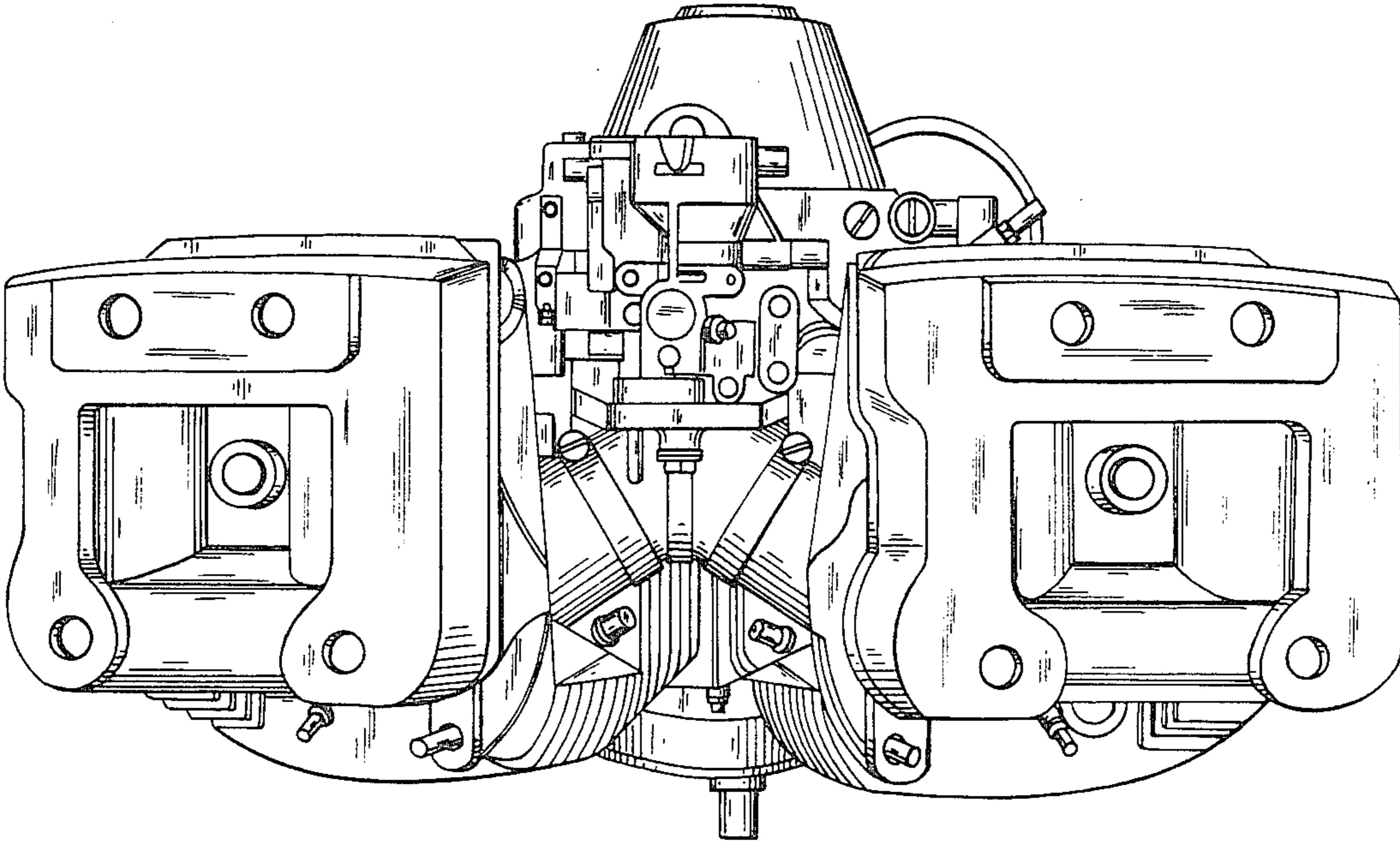

FIG. 5