

[54] **MOTORCYCLE**

[75] Inventors: **Norio Hoshi, Fujimi; Shigeru Hattori, Niiza, both of Japan**

[73] Assignee: **Honda Giken Kogyo Kabushiki Kaisha, Tokyo, Japan**

[**] Term: **14 Years**

[21] Appl. No.: **397,465**

[22] Filed: **Jul. 12, 1982**

[30] **Foreign Application Priority Data**

Jan. 12, 1982 [JP] Japan 57/878
[52] U.S. Cl. **D12/110**
[58] Field of Search D12/110; 180/219

[56] **References Cited**

U.S. PATENT DOCUMENTS

D. 270,047 8/1983 Kataoka et al. D12/110

OTHER PUBLICATIONS

Cycle World, 12/81, p. 53, Suzuki RM 250, center right side of page.
Cycle World, 7/80, p. 73, Honda RC 125-80, top left side of page.
Cycle World, 7/80, p. 74, Suzuki RA 125-80, top left side of page.
Motor Cyclist", Apr. 19, 1981, pp. 96, 97 and 102.

Primary Examiner—James M. Gandy
Attorney, Agent, or Firm—Armstrong, Nikaido, Marmelstein & Kubovcik

[57] **CLAIM**

The ornamental design for a motorcycle, as shown and described.

DESCRIPTION

FIG. 1 is a right side elevational view of a motorcycle, showing our new design;
FIG. 2 is a left side elevational view thereof;
FIG. 3 is a front elevational view thereof;
FIG. 4 is a rear elevational view thereof;
FIG. 5 is a top plan view thereof;
FIG. 6 is a bottom plan view thereof; and
FIG. 7 is a perspective view thereof.

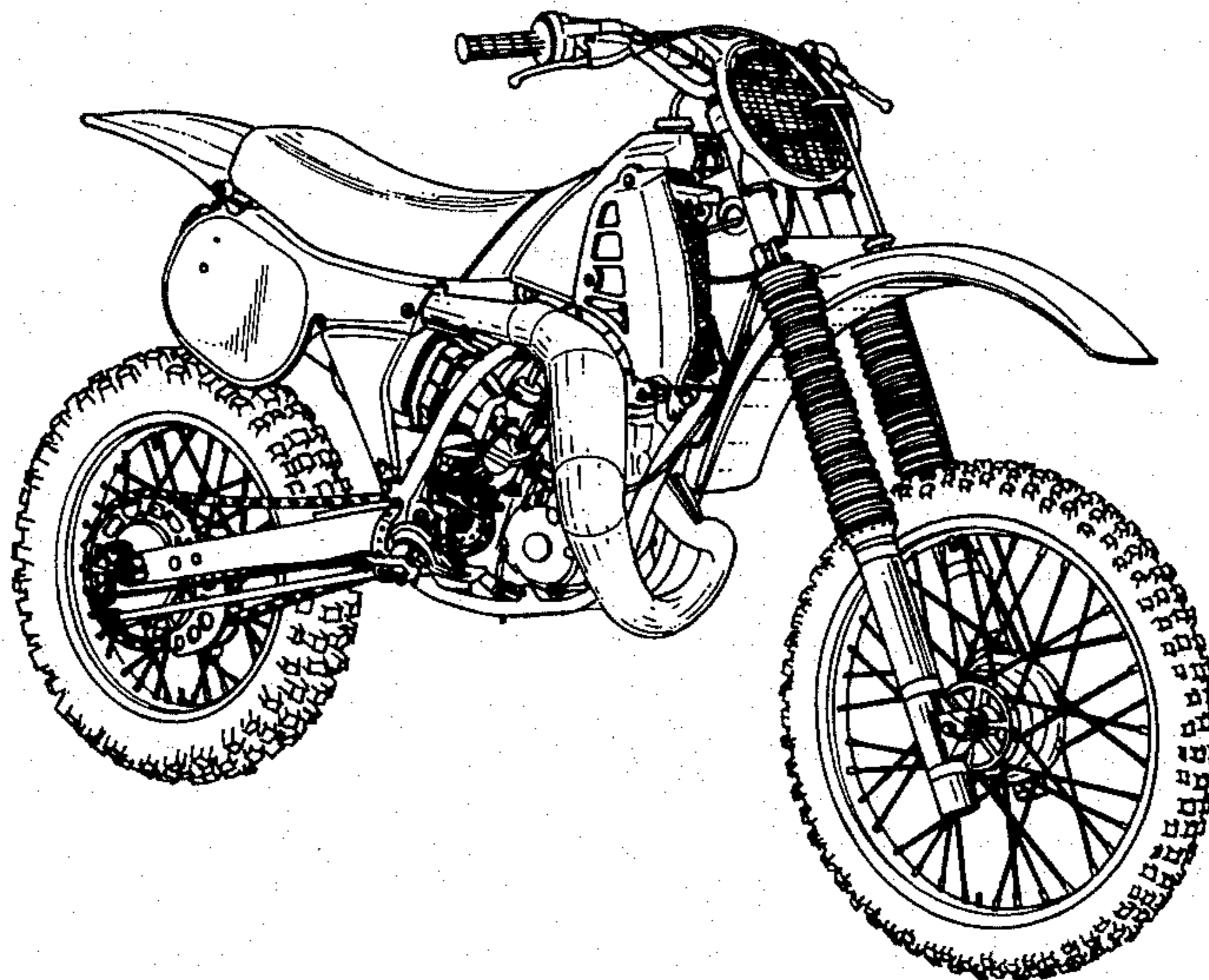

FIG. 1

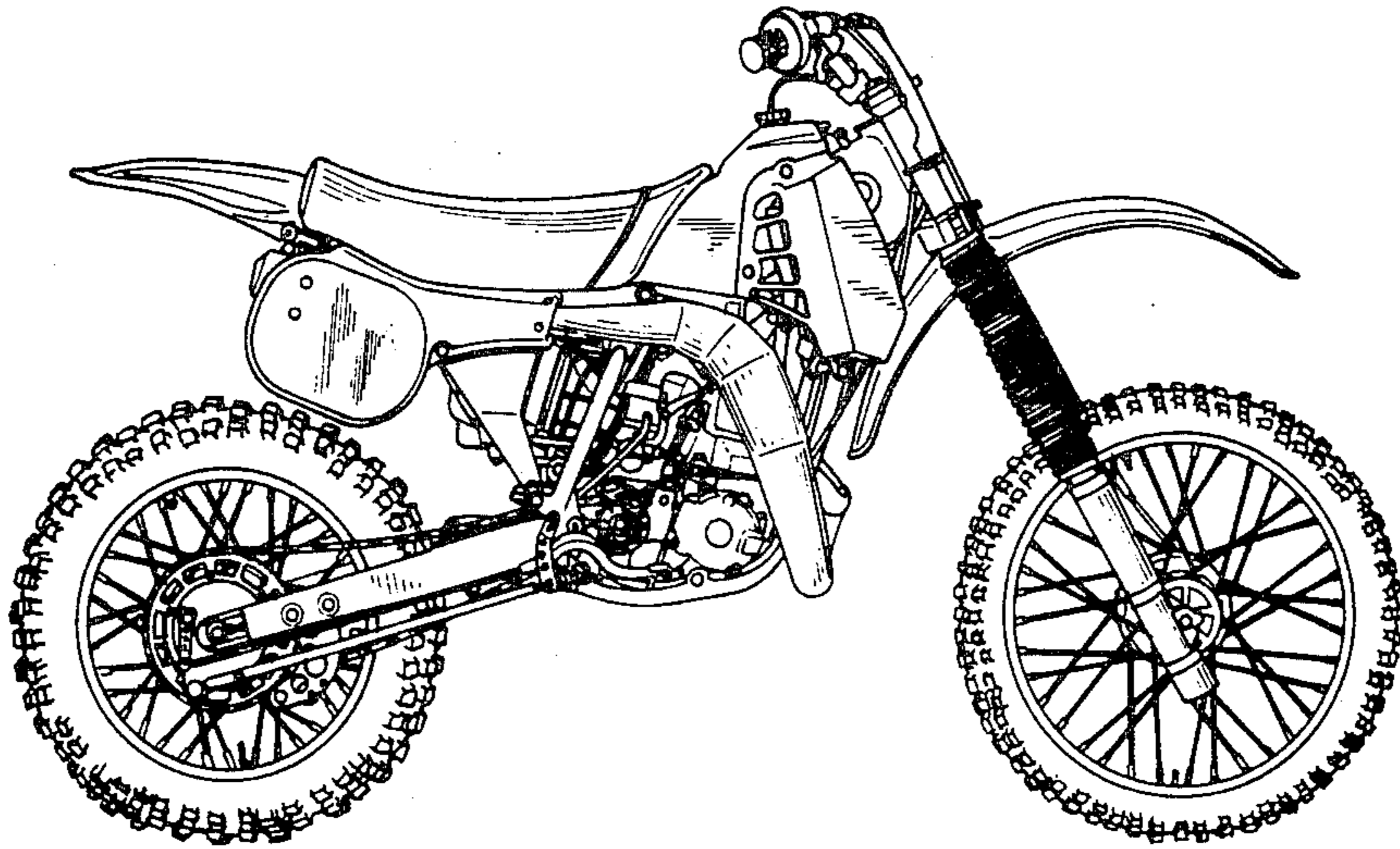

FIG. 2

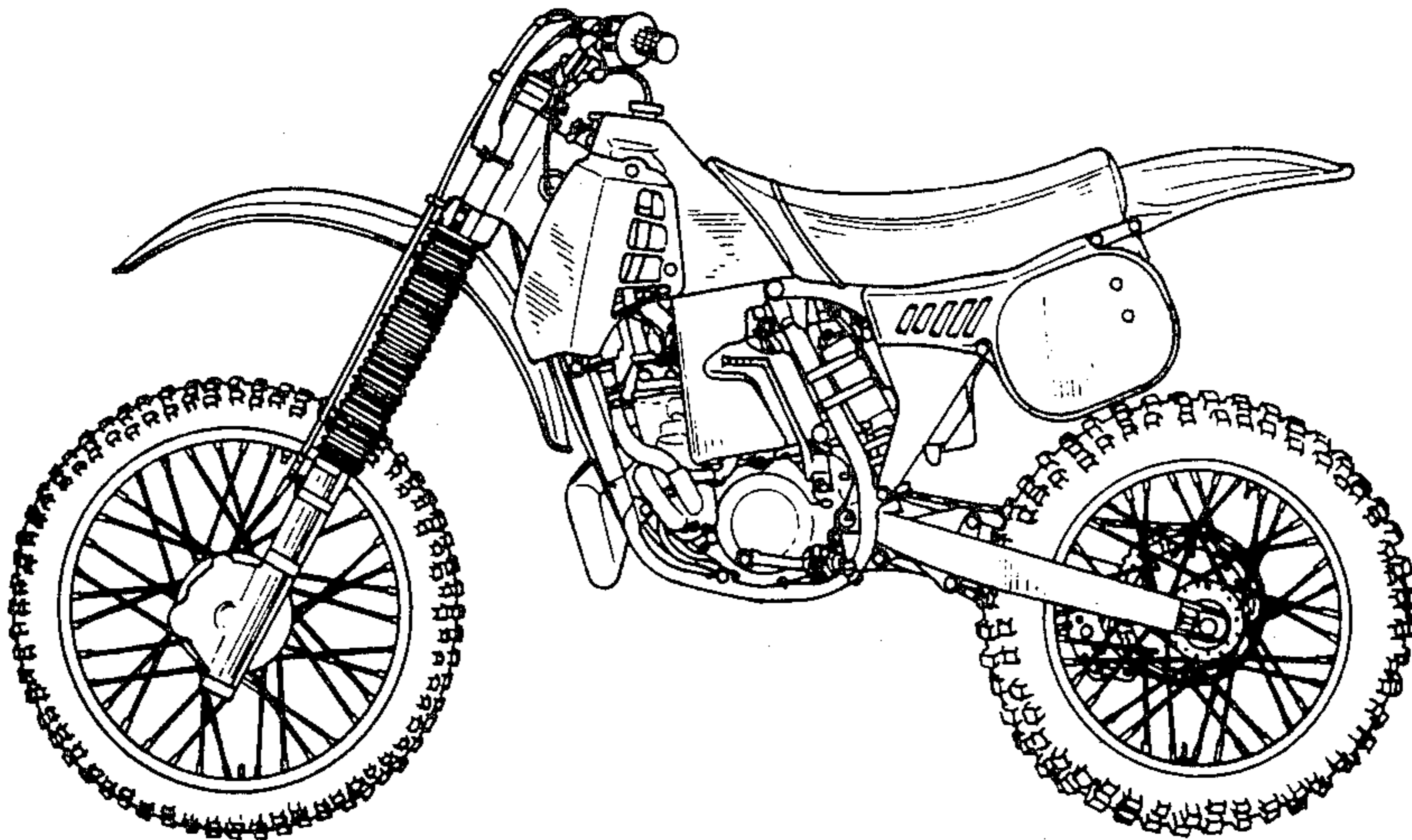

FIG.3

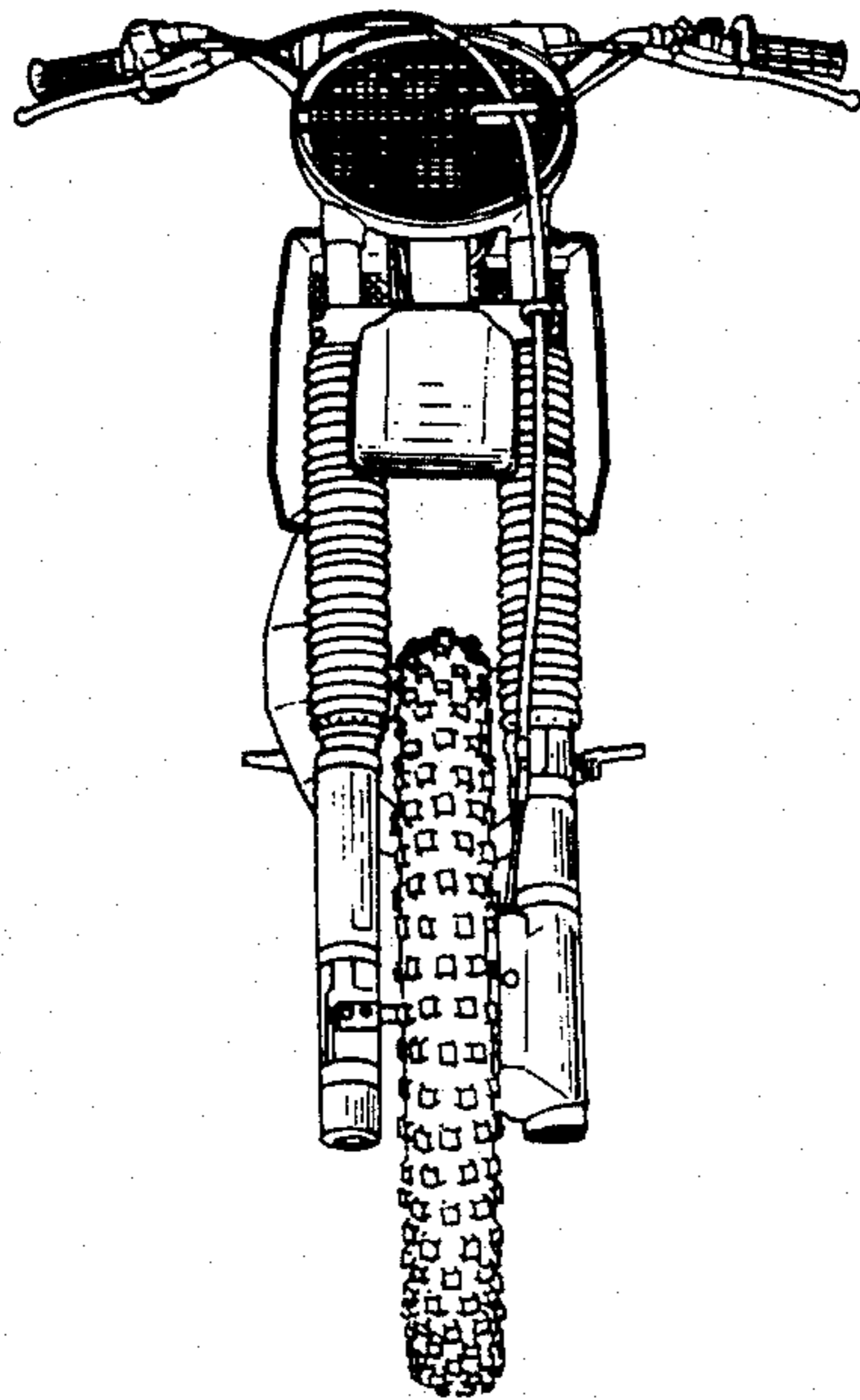

FIG.4

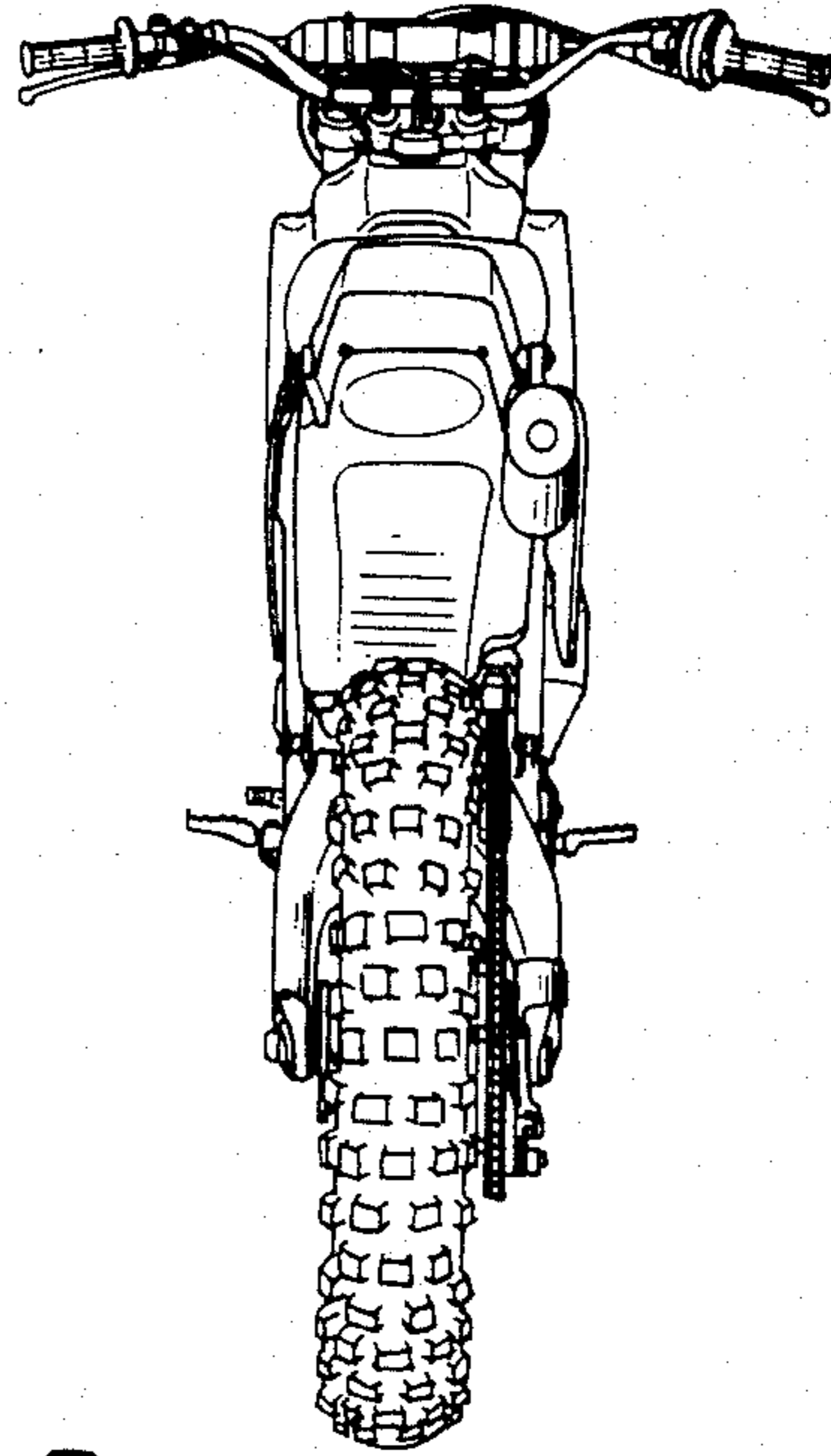

FIG.5

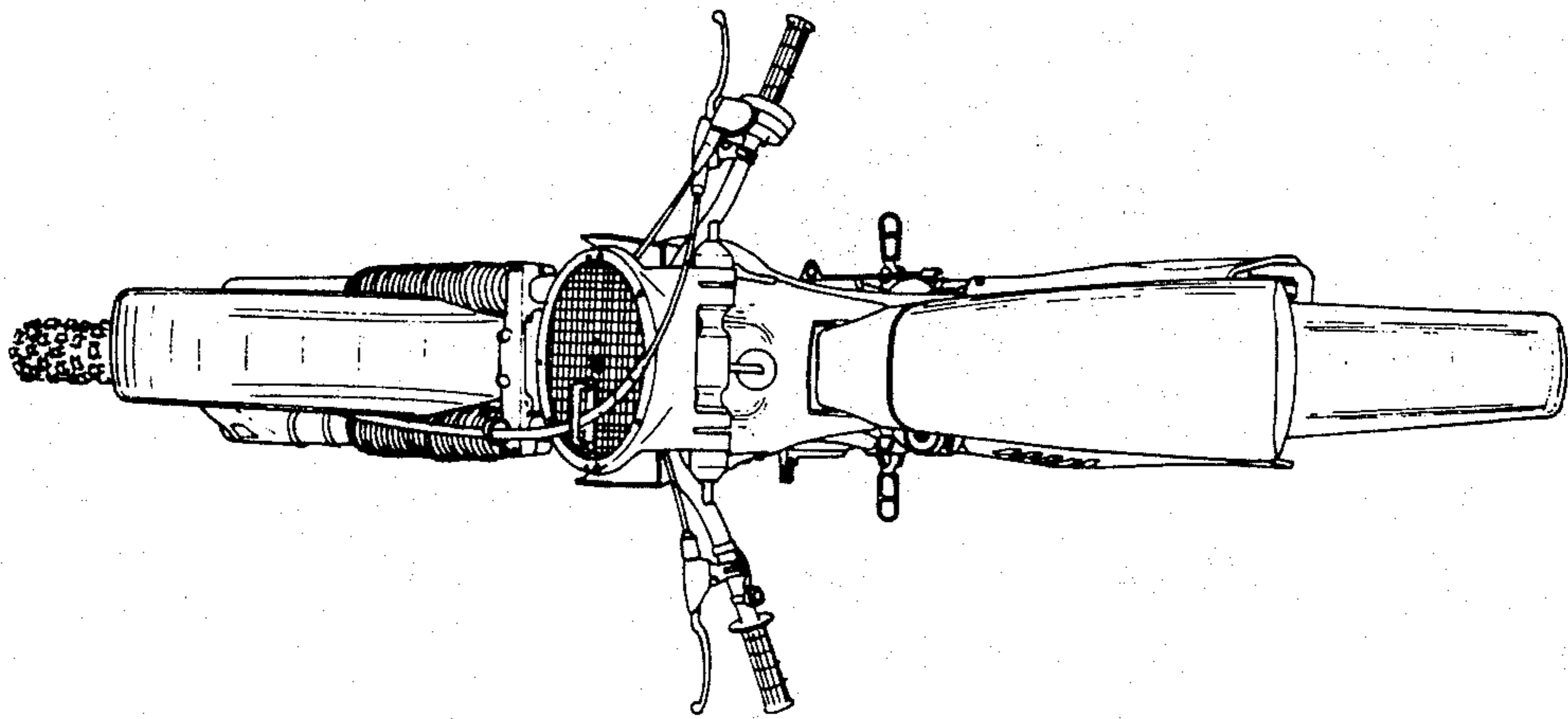

FIG. 6

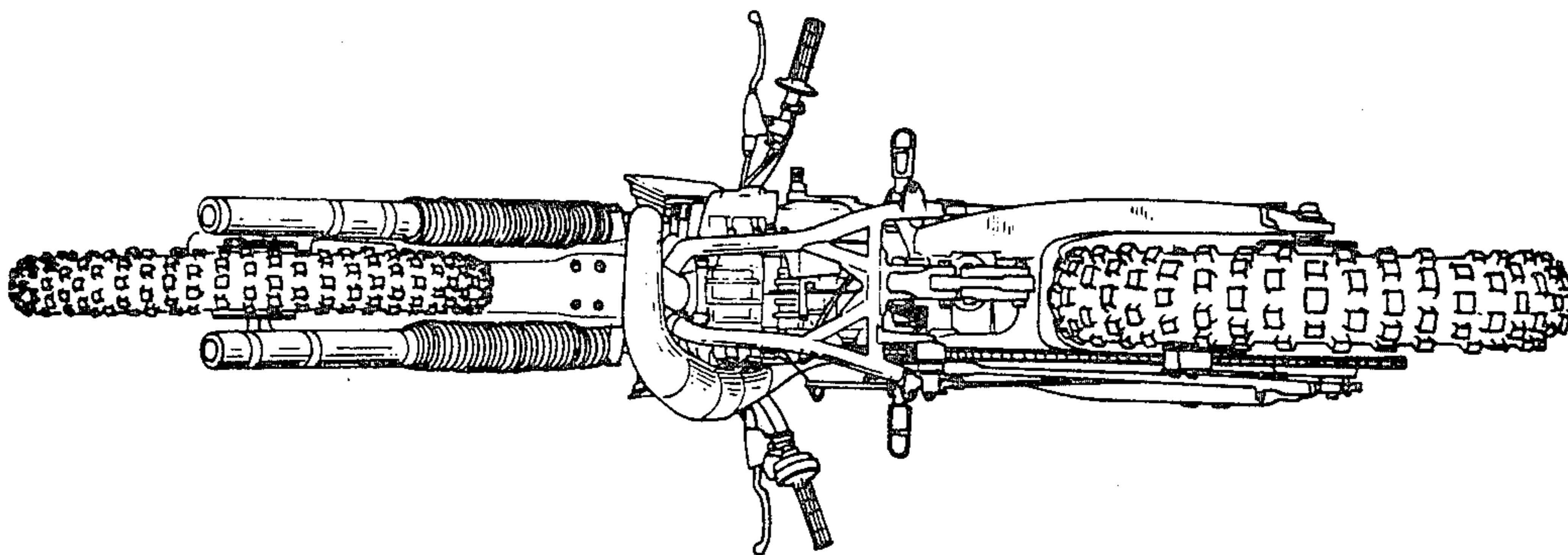

FIG. 7

