

[54] TOY PICKUP TRUCK

- [75] Inventor: Karl D. Lerch, East Aurora, N.Y.
- [73] Assignee: The Quaker Oats Company, Chicago, Ill.
- [\*\*] Term: 14 Years
- [21] Appl. No.: 461,610
- [22] Filed: Jan. 27, 1983
- [52] U.S. Cl. .... D21/136; D21/134
- [58] Field of Search ..... D21/76, 78, 79, 80, D21/128, 132, 134, 135, 136, 137, 138, 139, 140; 446/441, 449, 451, 457, 465; D12/96, 97, 93

[56] References Cited

U.S. PATENT DOCUMENTS

- D. 219,666 1/1971 Gilford ..... D21/140
- D. 222,837 1/1972 Muys et al. .... D21/140
- D. 257,049 9/1980 Okado ..... D21/134

OTHER PUBLICATIONS

- Hong Kong Toys, 1982, page of "Shing Fat Diecasting Factory Ltd.", Toy Jeep.
- Hong Kong Toys, 1982, page of "Dynamic Toys Ltd.", Mini Honda.
- Chevrolet Flier, front cover, Vehicle at bottom of page.

Primary Examiner—Charles A. Rademaker  
Attorney, Agent, or Firm—Cumpston & Shaw

[57] CLAIM

The ornamental design for a toy pickup truck, substantially as shown and described.

DESCRIPTION

FIG. 1 is a left-side elevational view of a toy pickup truck showing my new design, the right side being substantially a mirror image;  
 FIG. 2 is a top plan view thereof;  
 FIG. 3 is a bottom plan view thereof;  
 FIG. 4 is a front elevational view thereof; and  
 FIG. 5 is a rear elevational view thereof.

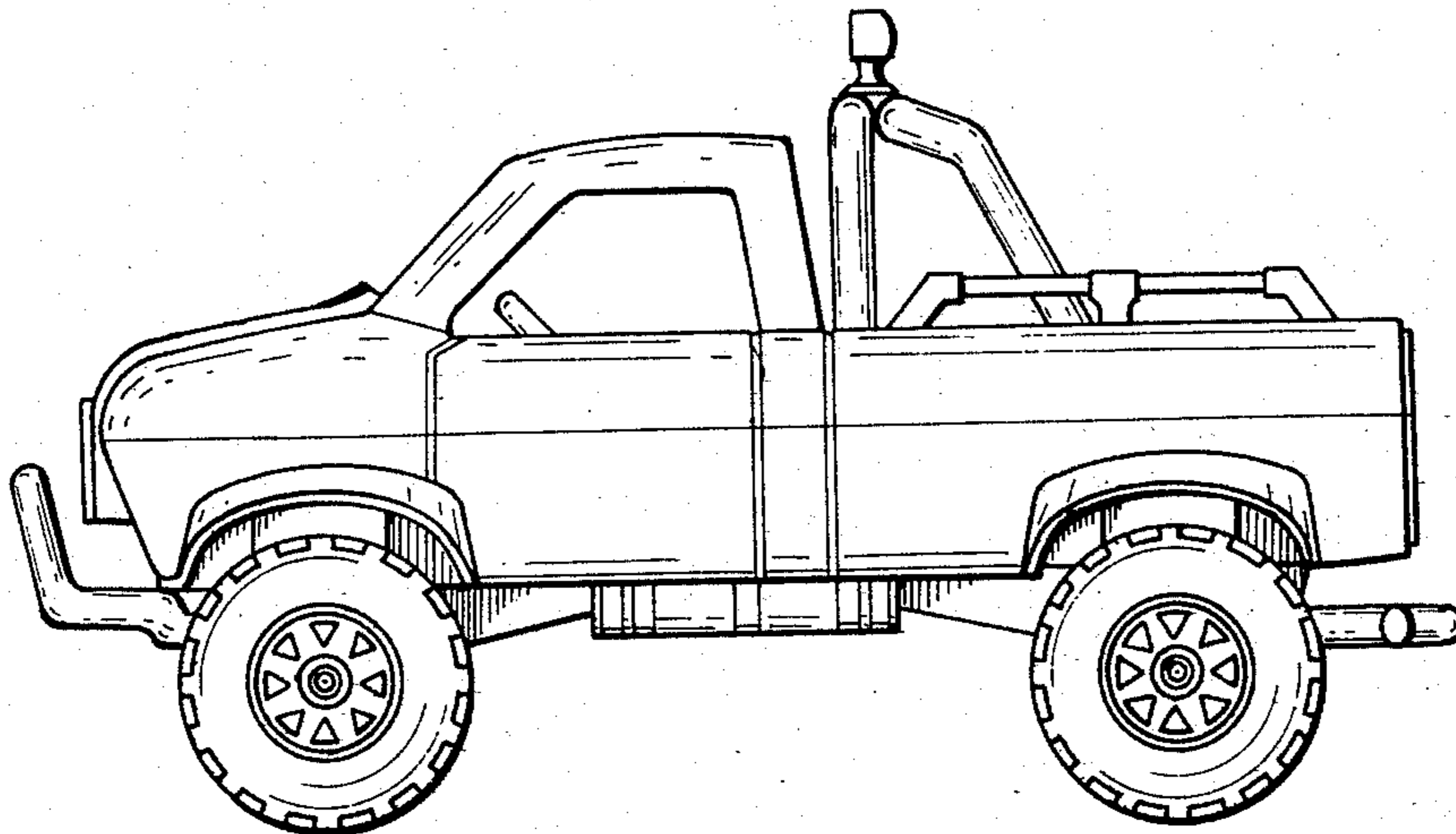

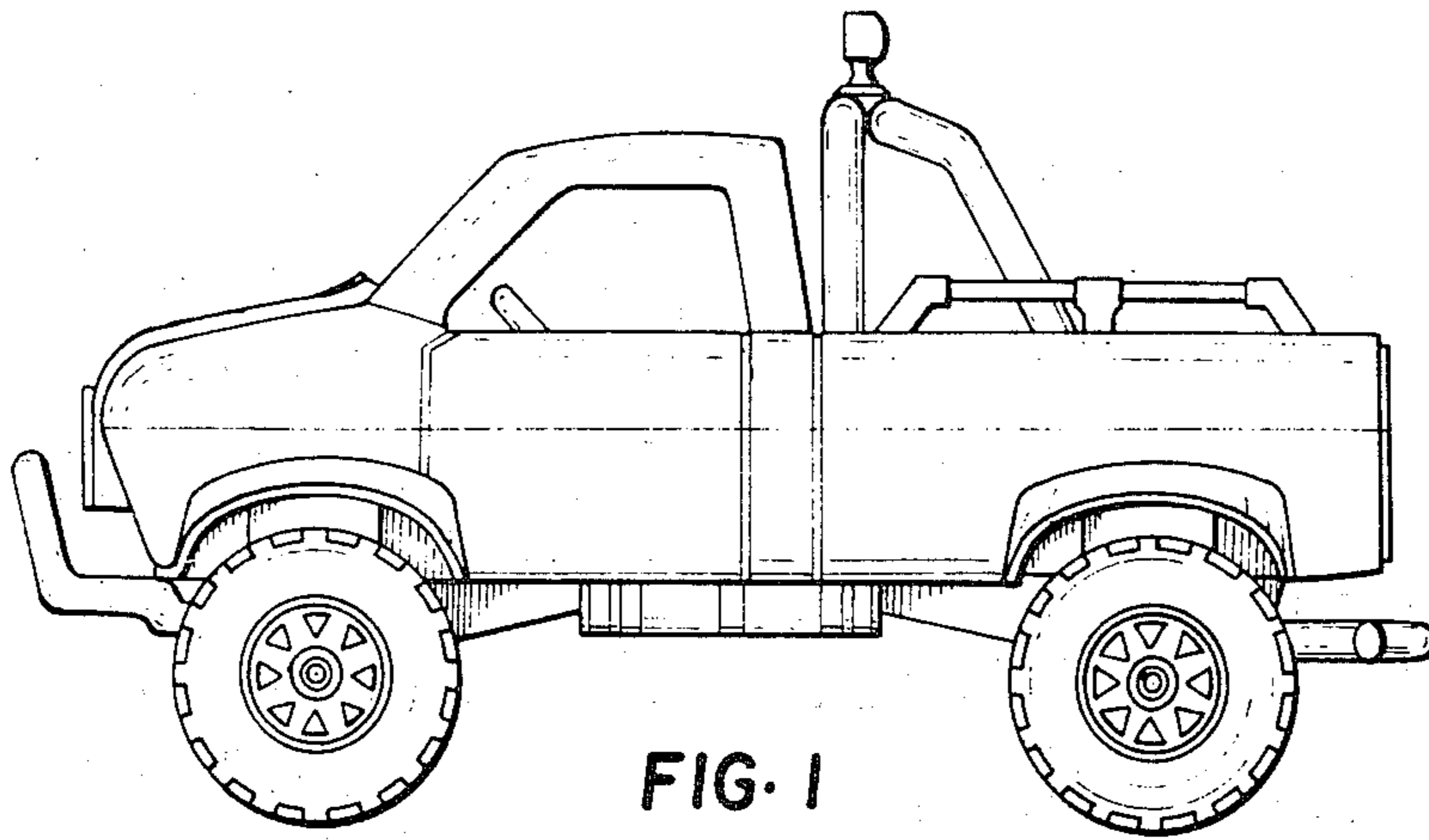

FIG. 1

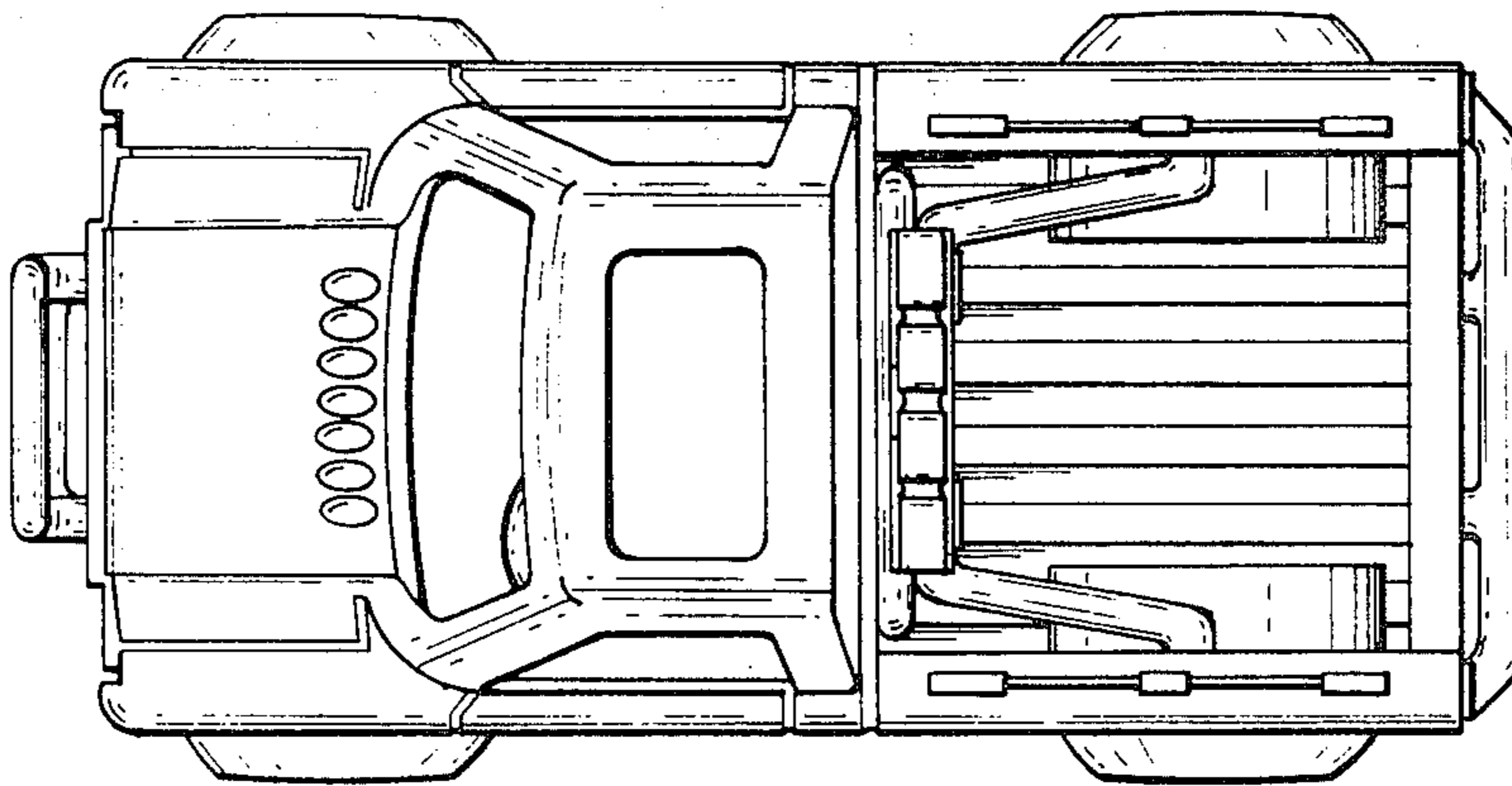

FIG. 2

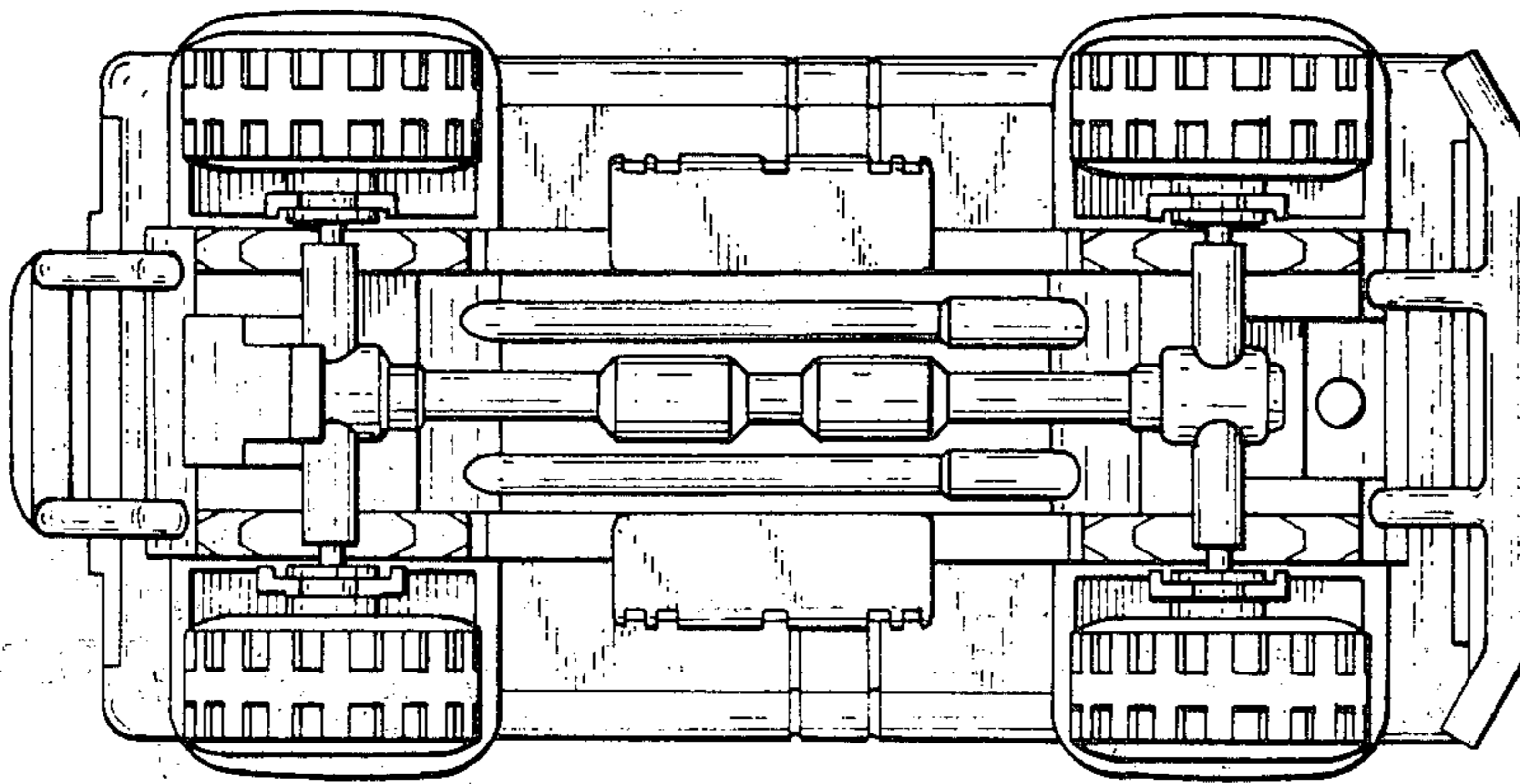

FIG. 3

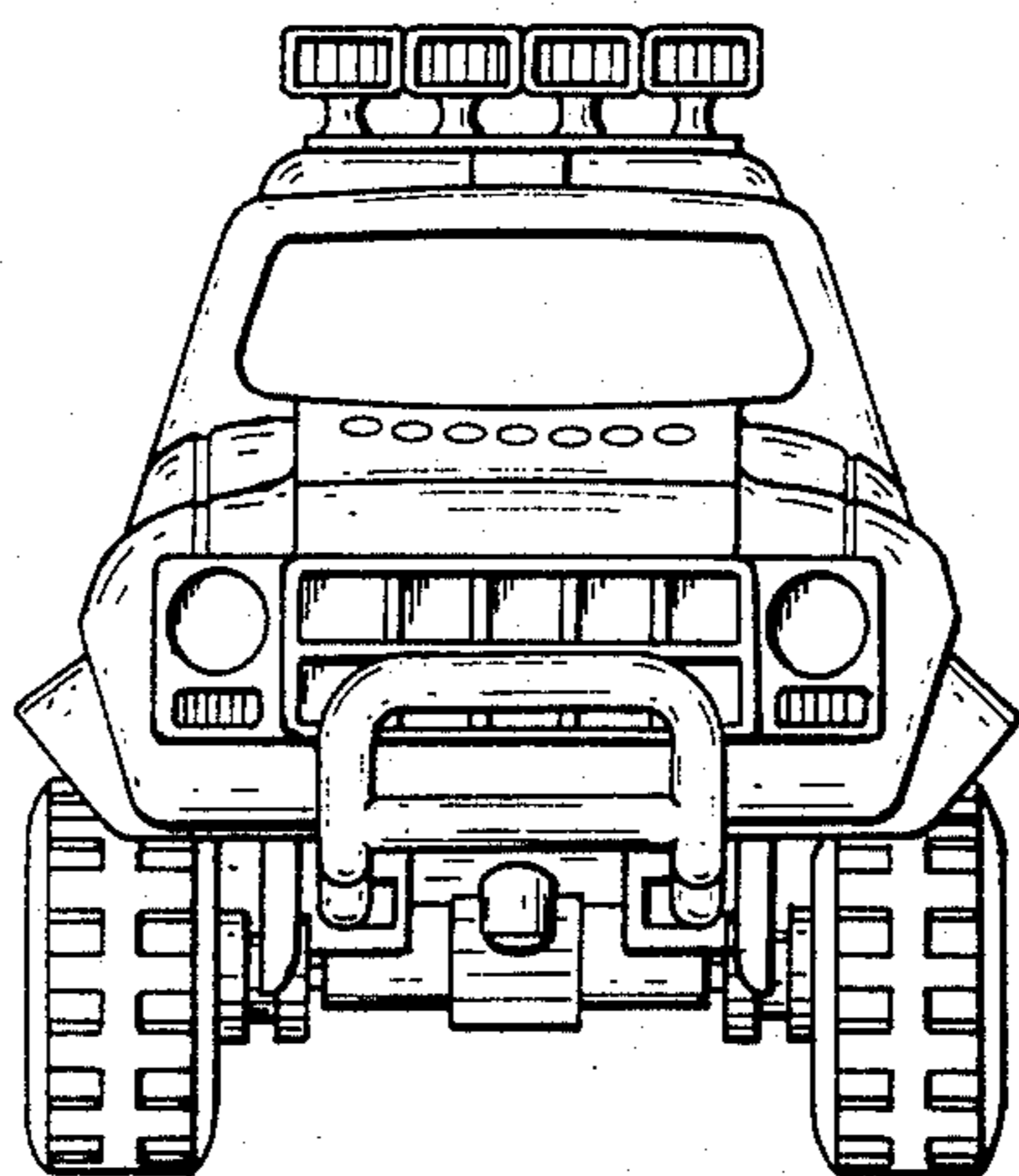

FIG. 4

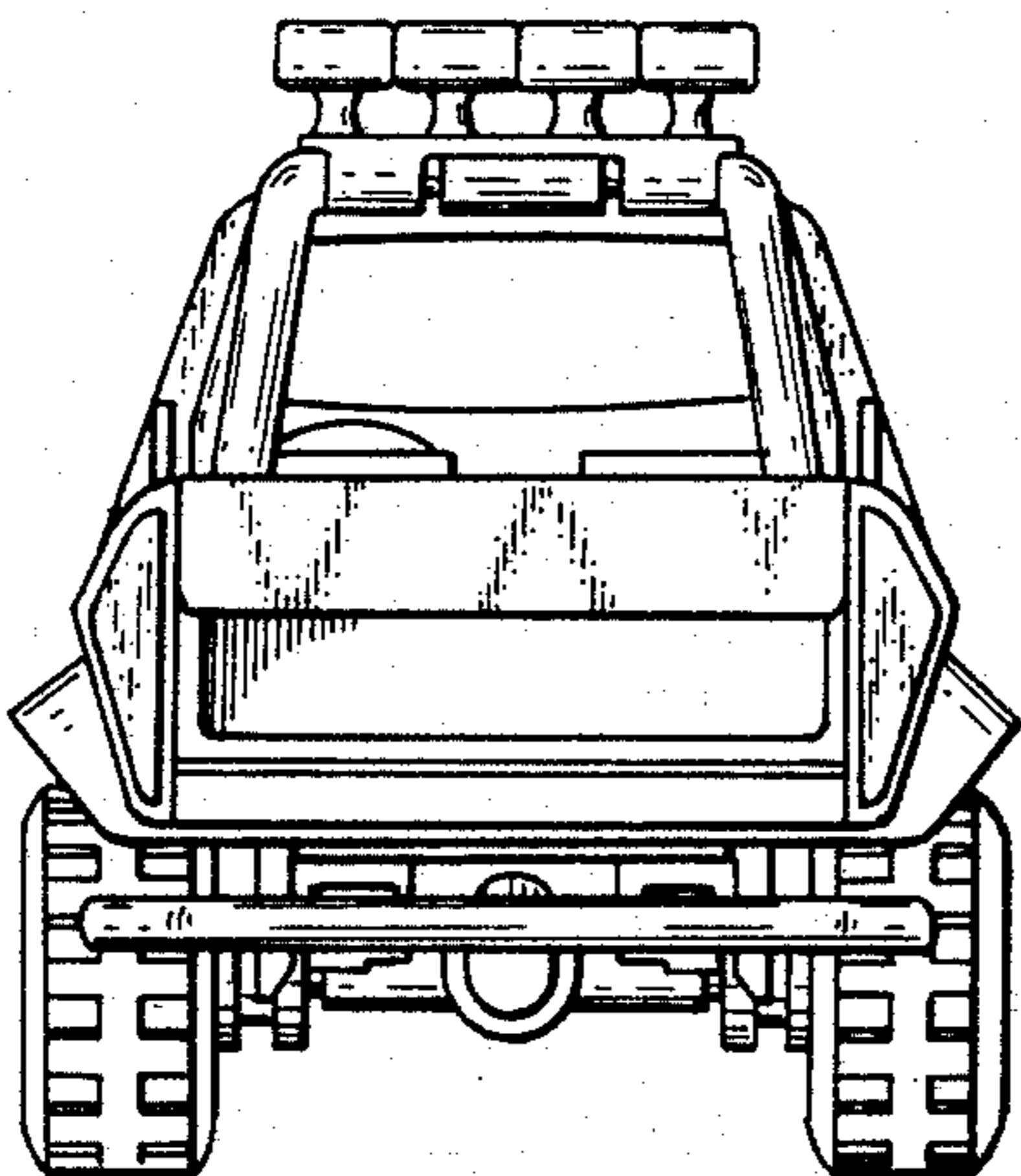

FIG. 5