

[54] COMBINED TRANSMISSION AND PROPELLER ASSEMBLY FOR BOATS

[75] Inventors: Kjell Borgersen, Hjalteby; Lennart Brandt, Fjaras, both of Sweden

[73] Assignee: AB Volvo Penta, Gothenburg, Sweden

[\*\*] Term: 14 Years

[21] Appl. No.: 301,964

[22] Filed: Sep. 14, 1981

Related U.S. Application Data

[62] Division of Ser. No. 105,242, Dec. 19, 1979, Pat. No. Des. 264,724.

[52] U.S. Cl. .... D15/149; D15/4

[58] Field of Search ..... D15/149, 4; 74/606 R; 440/75, 76

[56] References Cited

U.S. PATENT DOCUMENTS

D. 191,021	8/1961	Hansson .....	D15/4
D. 198,553	6/1964	Kiekhaefer et al. ....	D15/4
2,681,029	6/1954	Canazzi .....	74/606 R
3,001,409	9/1961	Von Fumevvi .....	74/606 R
3,236,114	2/1966	Freber .....	74/606 R
3,463,029	8/1969	Chow .....	74/606 R
4,037,558	7/1977	Nossiter .....	440/75

Primary Examiner—B. J. Bullock  
Attorney, Agent, or Firm—Young & Thompson

[57] CLAIM

The ornamental design for a combined transmission and propeller assembly for boats, as shown.

DESCRIPTION

FIG. 1 is a perspective view of a combined transmission and propeller assembly for boats showing our new design;

FIG. 2 is a side elevational view of the side shown in FIG. 1;

FIG. 3 is a perspective view of the side opposite that shown in FIG. 1.

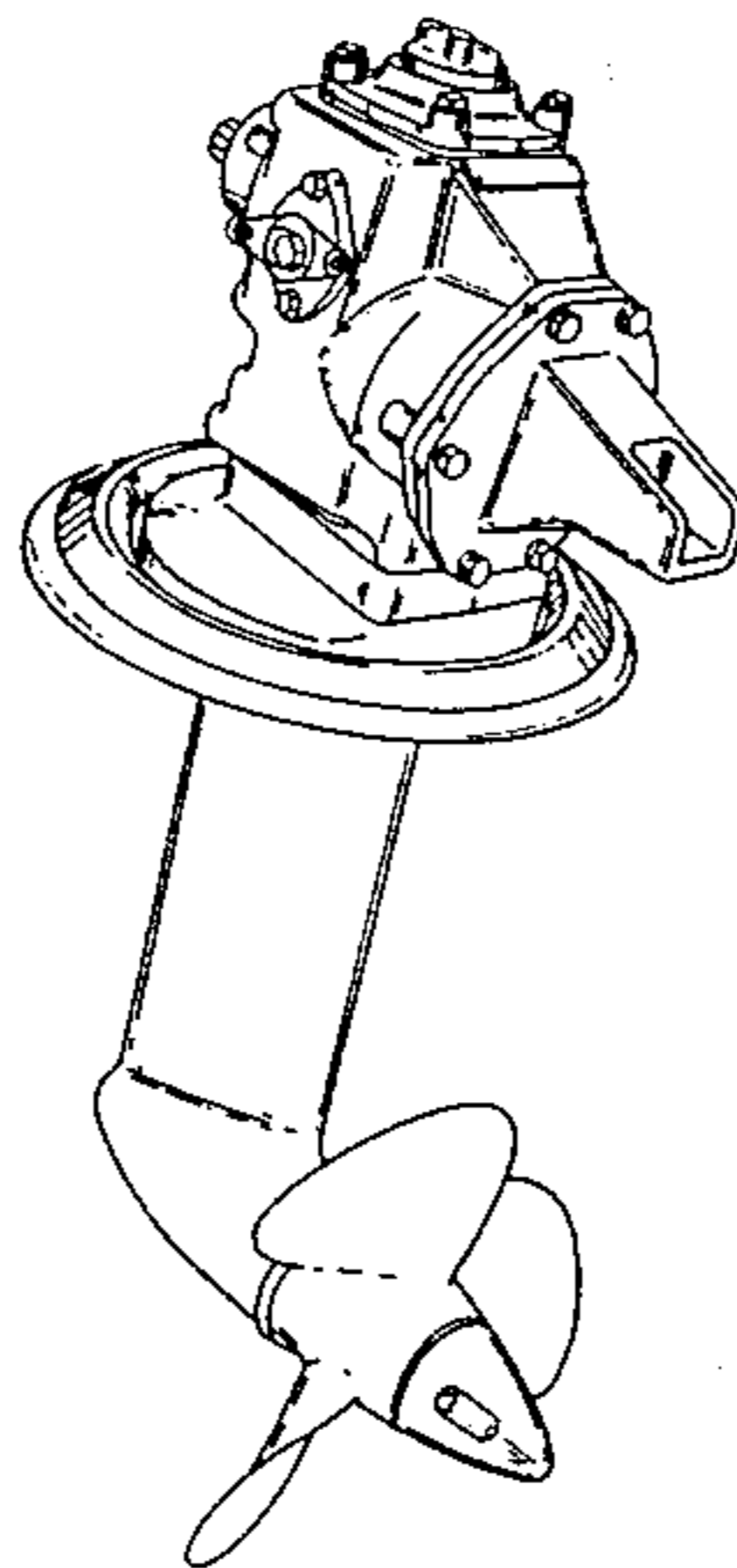

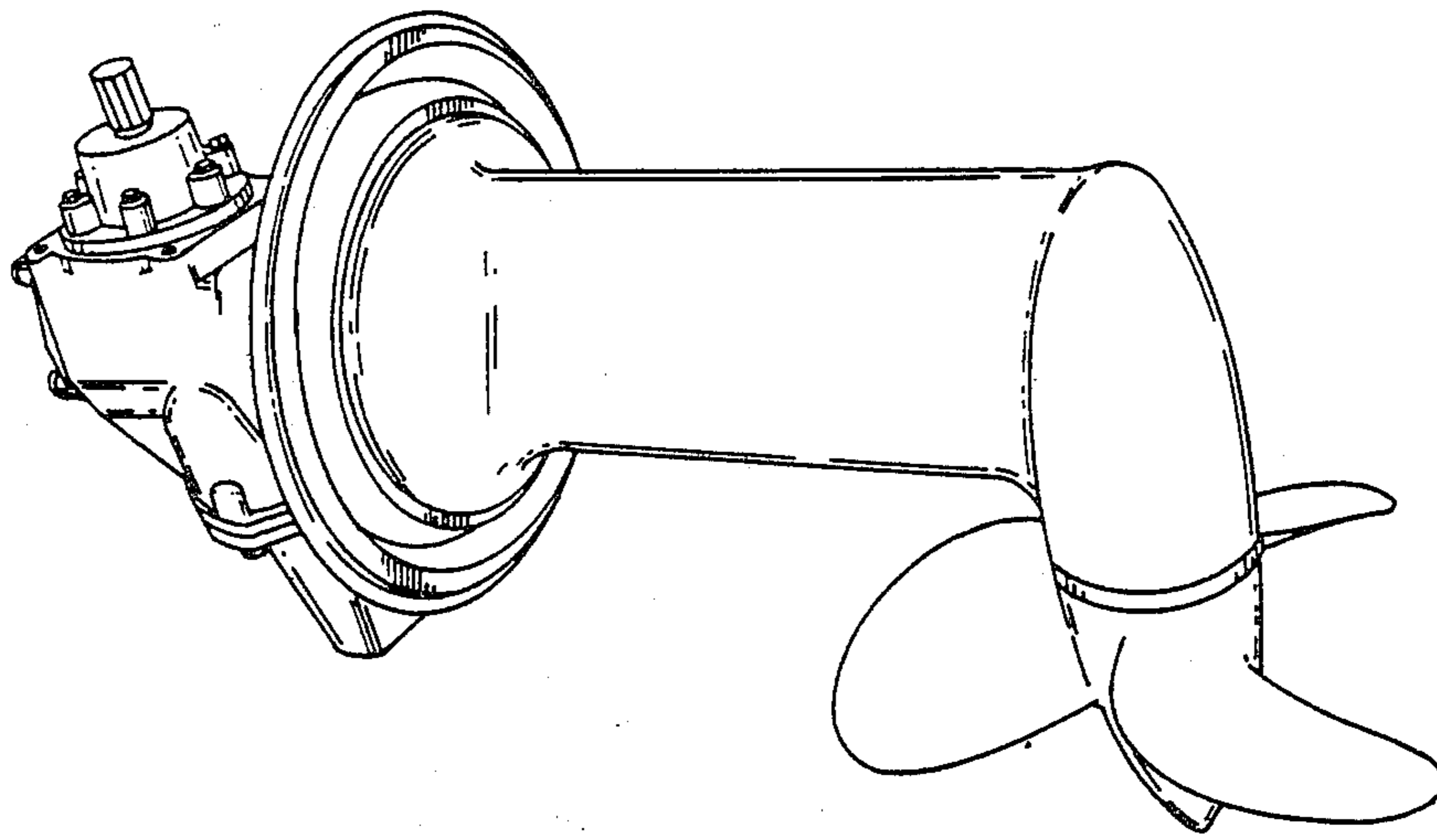

FIG 1

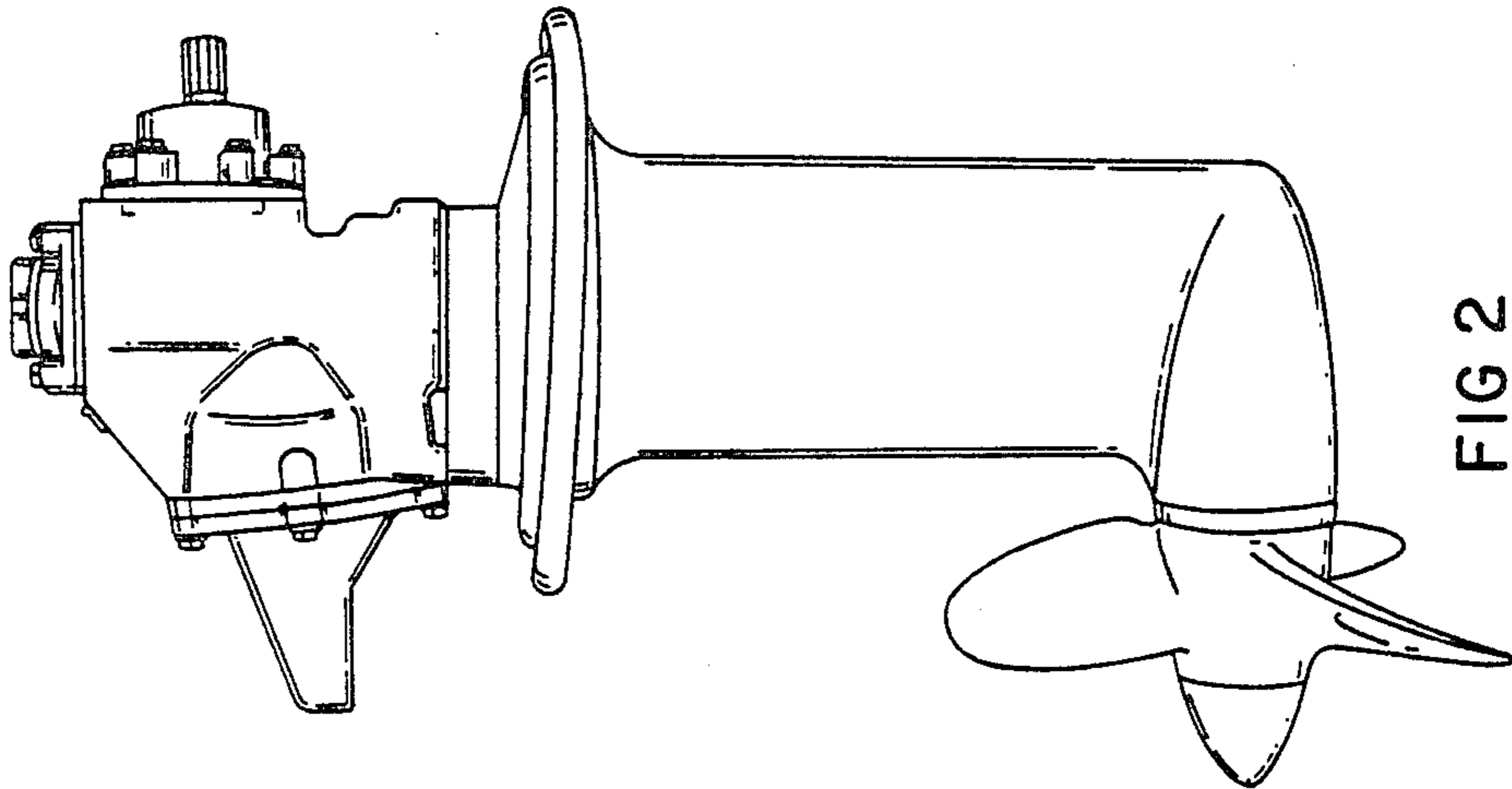

FIG 2

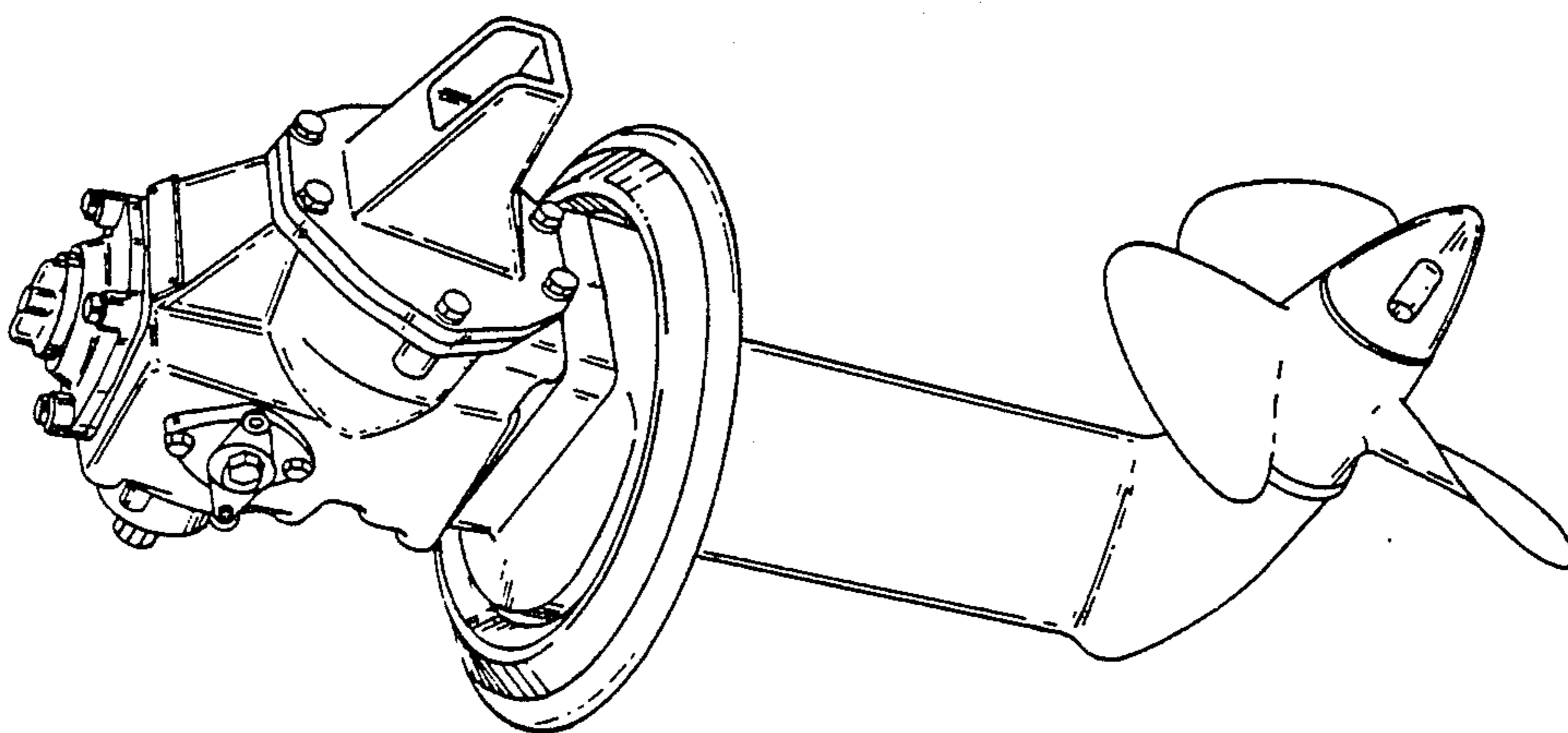

FIG 3