

[54] BOTTLE OPENER

4,337,678 7/1982 Mumford D8/38 X
4,414,865 11/1983 Brooks et al. 81/3.1 R

[76] Inventor: Howard J. Antone, 12284 Adine Ct.,
Glen Ellen, Calif. 95442

OTHER PUBLICATIONS

[**] Term: 14 Years

The Fasteners Book, 9-1960, p. 122, Items "Esna Double/Durability Nut" & Esna Lightweight Locknut.

[21] Appl. No.: 385,458

Primary Examiner—Bernard Ansher

[22] Filed: Jun. 7, 1982

Assistant Examiner—Terry Pfeffer

[52] U.S. Cl. D8/40; 81/3.4;
7/151

Attorney, Agent, or Firm—Limbach, Limbach & Sutton

[58] Field of Search D8/18, 33, 38, 40, 387,
D8/397; 81/3.1 R, 3.34, 3.4, 3.46, 3.34; 7/151,
152; D7/43; D32/40

[57] CLAIM

The ornamental design for a bottle opener, as shown and described.

[56] References Cited

DESCRIPTION

U.S. PATENT DOCUMENTS

D. 208,875	10/1967	Fiegel	D8/18
D. 218,674	9/1970	Ernest	D8/397
D. 261,854	11/1981	Nielsen	D8/40
D. 271,817	12/1983	Collin	D32/40
1,919,866	7/1933	Schacht	81/3.4
3,225,714	12/1965	Gaskell	D7/43 X
3,812,741	5/1974	Heine	7/151

FIG. 1 is a top perspective view of a bottle opener showing my new design; broken lines illustrating the cap member are shown for illustrative purposes only; FIG. 2 is a top plan view thereof; FIG. 3 is a side elevation thereof; FIG. 4 is a bottom plan view thereof; and FIG. 5 is a cross section taken along lines 5—5 of FIG. 2.

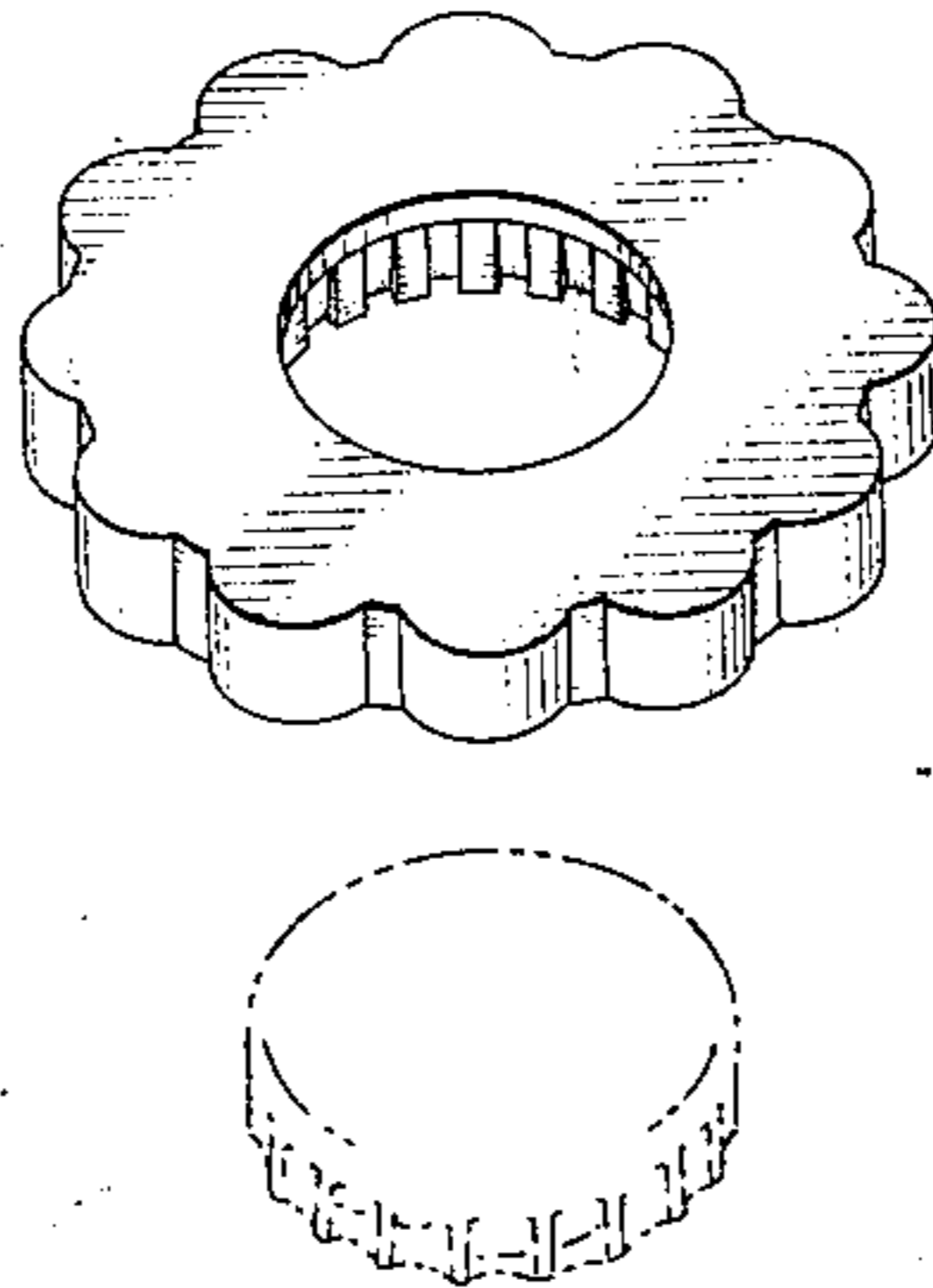

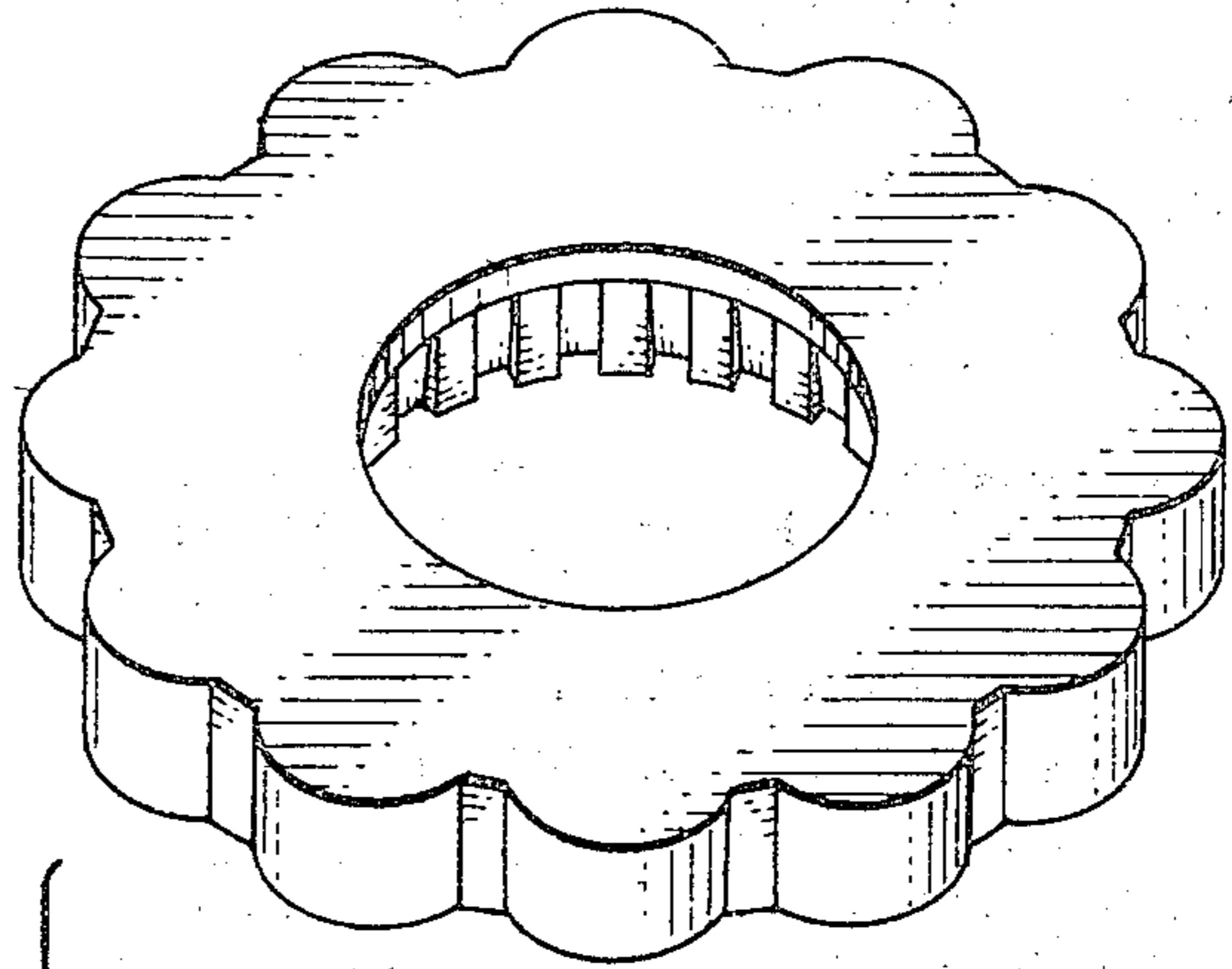

FIG. 1

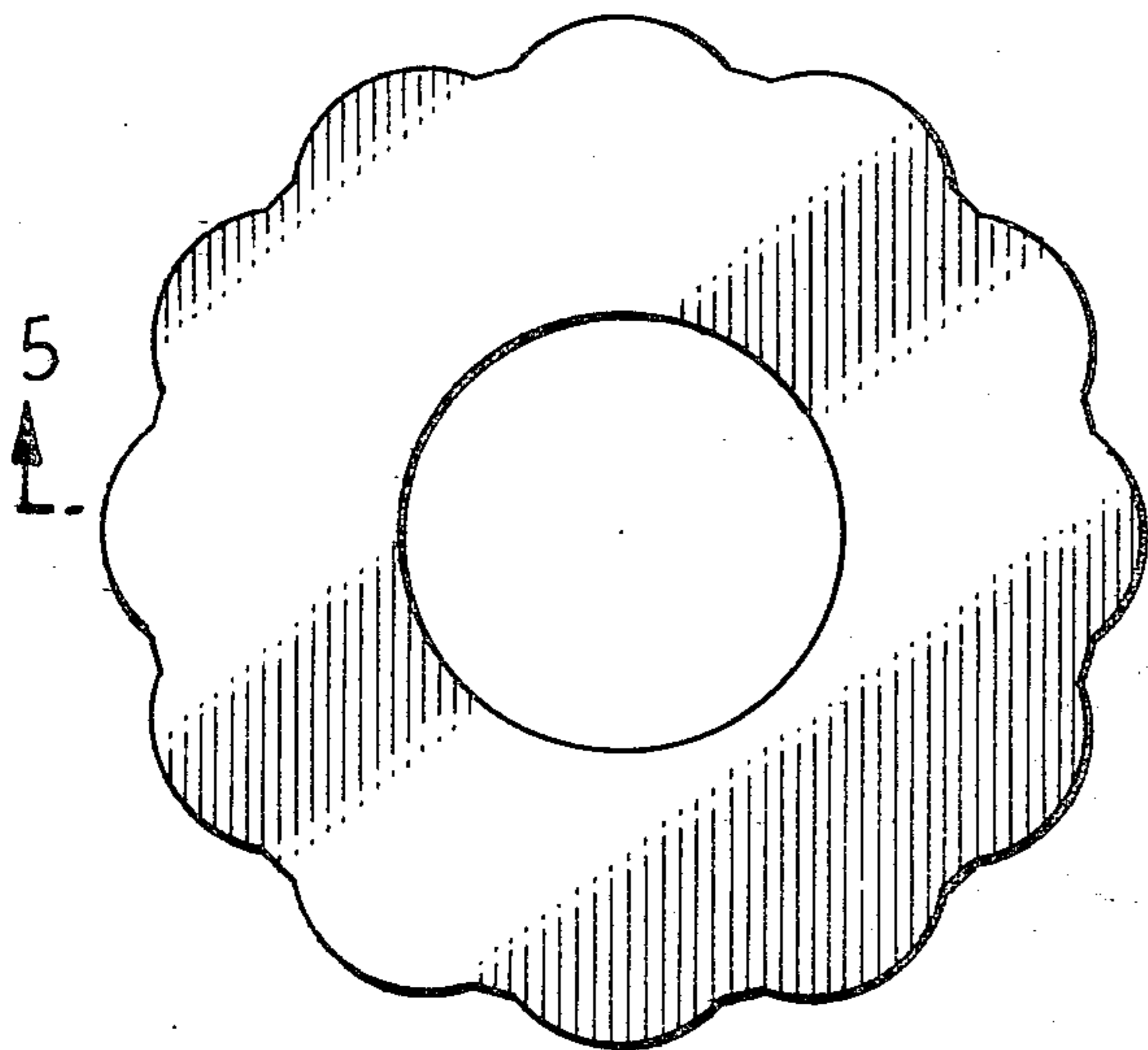
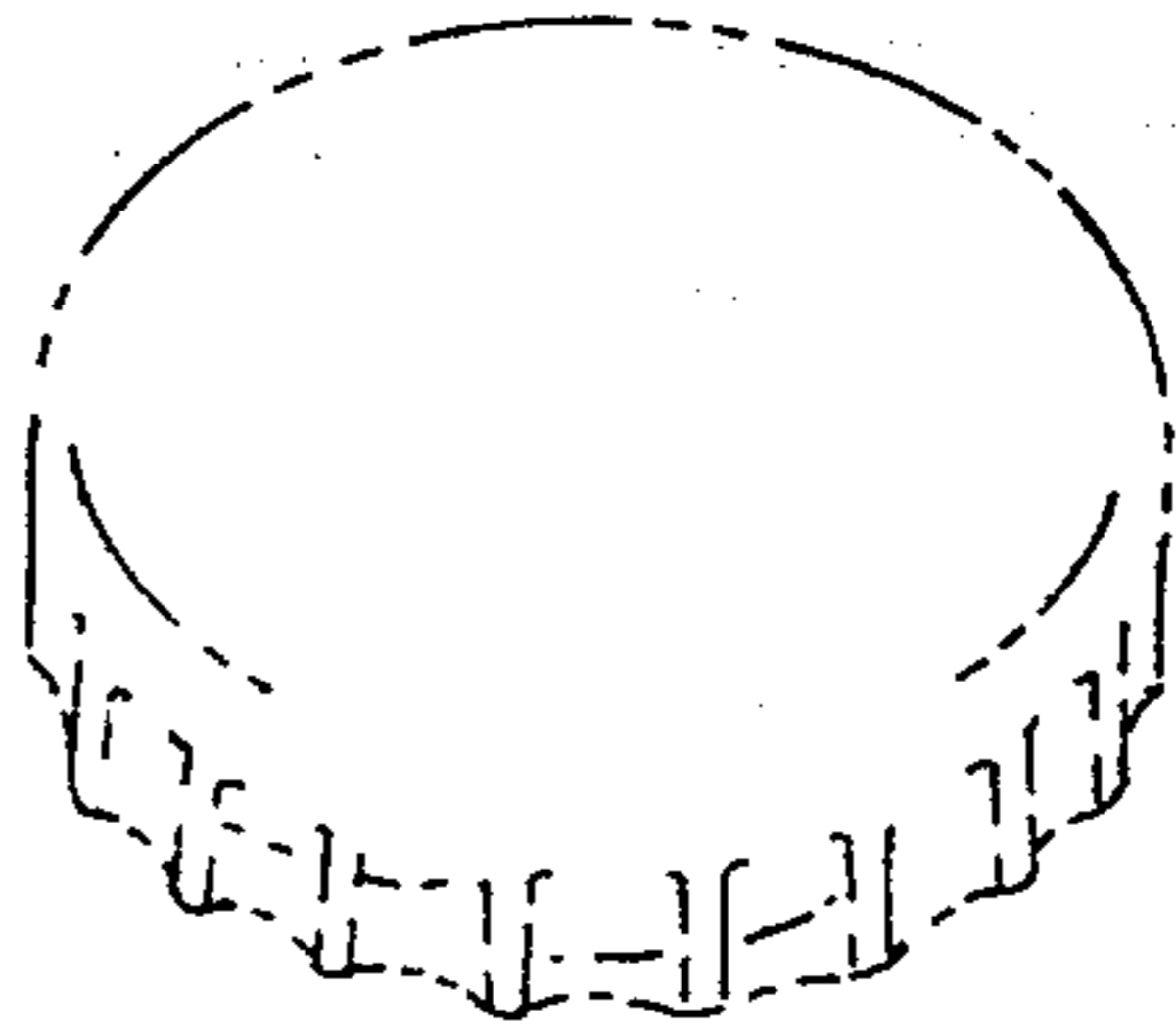

FIG. 2

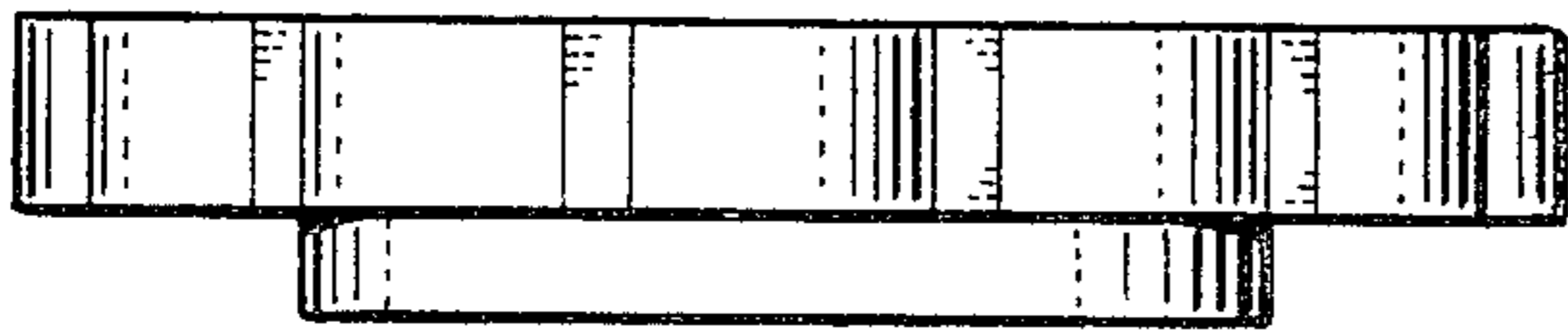

FIG. 3

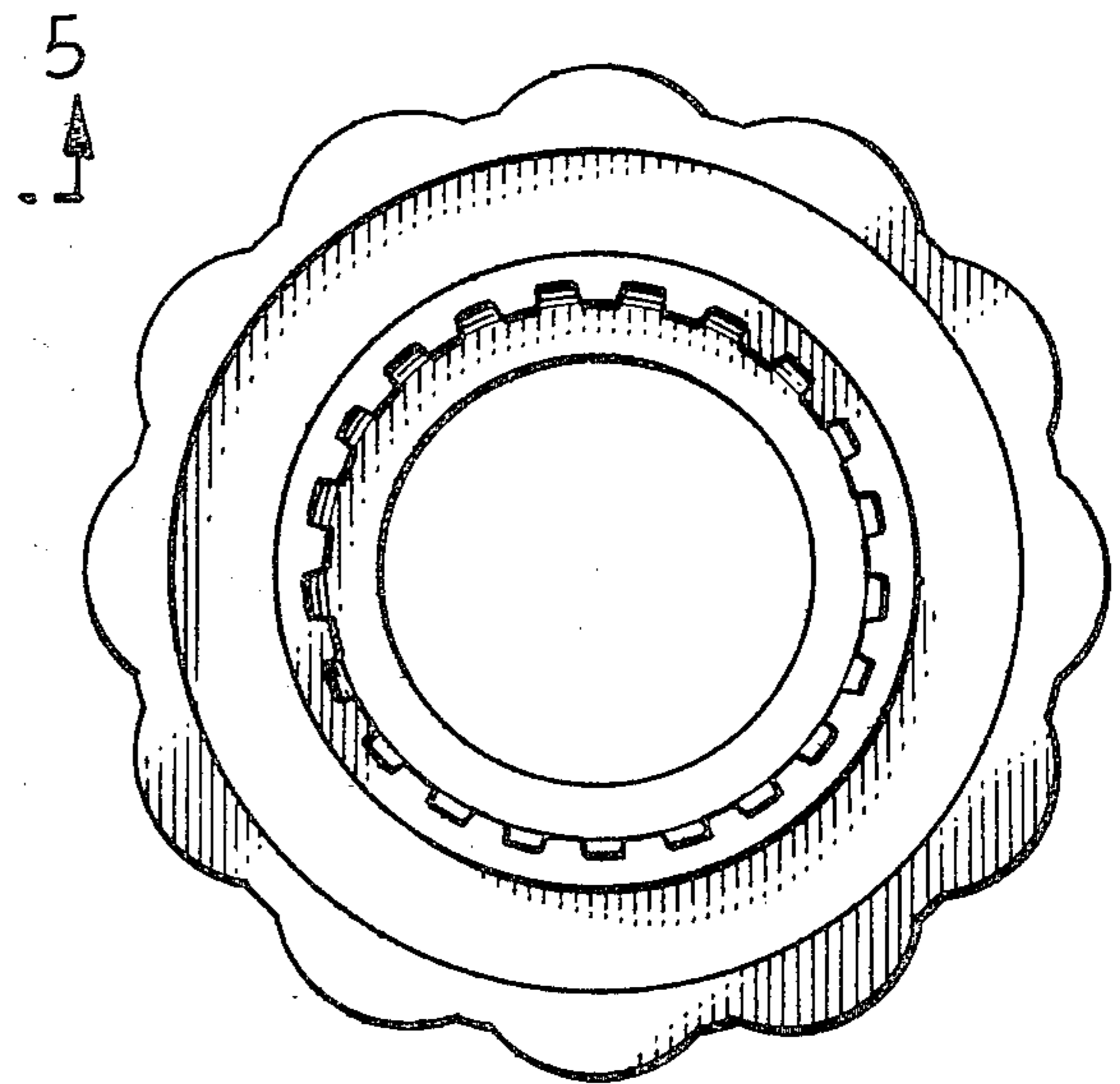

FIG. 4



FIG. 5