

- [54] **MOTORIZED BUMPER BOAT**
- [75] Inventors: **Ralph V. Ball**, Laguna Niguel; **John E. Pape**, El Cajon, both of Calif.
- [73] Assignee: **J & J Recreation, Inc.**, San Juan Capistrano, Calif.
- [\*\*] Term: **14 Years**
- [21] Appl. No.: **380,122**
- [22] Filed: **May 20, 1982**
- [52] U.S. Cl. .... **D12/307**
- [58] Field of Search ..... **D12/305, 309, 307, 300, D12/311, 313, 314, 316, 306; 114/345, 346; 46/93**

3,339,514 12/1965 Skuce ..... D12/307  
 4,367,689 1/1983 Lukehart et al. .... 114/346

**OTHER PUBLICATIONS**

Photographs of "Water Bug" Bumper Boat submitted by Applicant.

*Primary Examiner*—James M. Gandy  
*Assistant Examiner*—K. H. Chin  
*Attorney, Agent, or Firm*—Knobbe, Martens, Olson & Bear

**CLAIM**

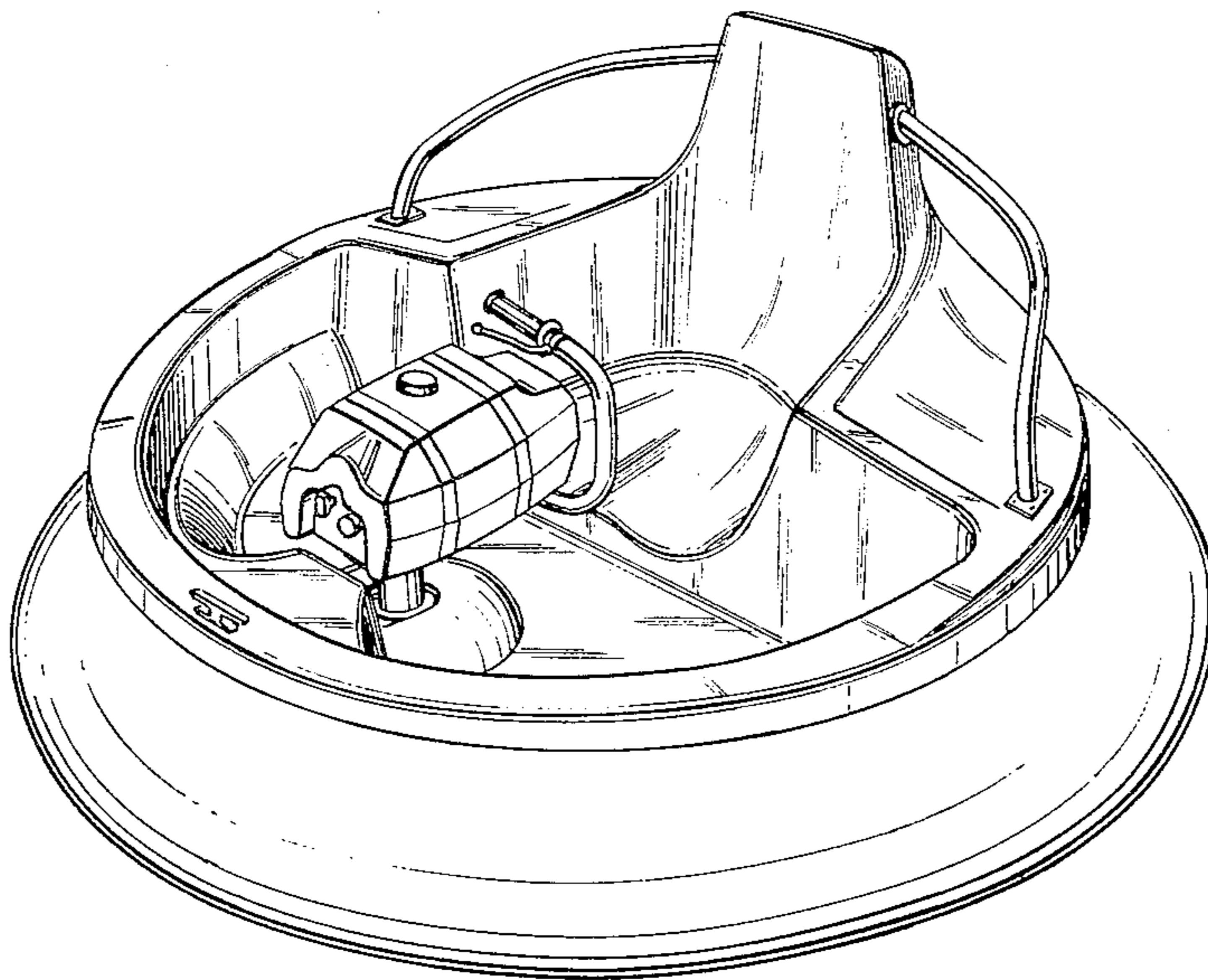
The ornamental design for a motorized bumper boat, as shown.

**DESCRIPTION**

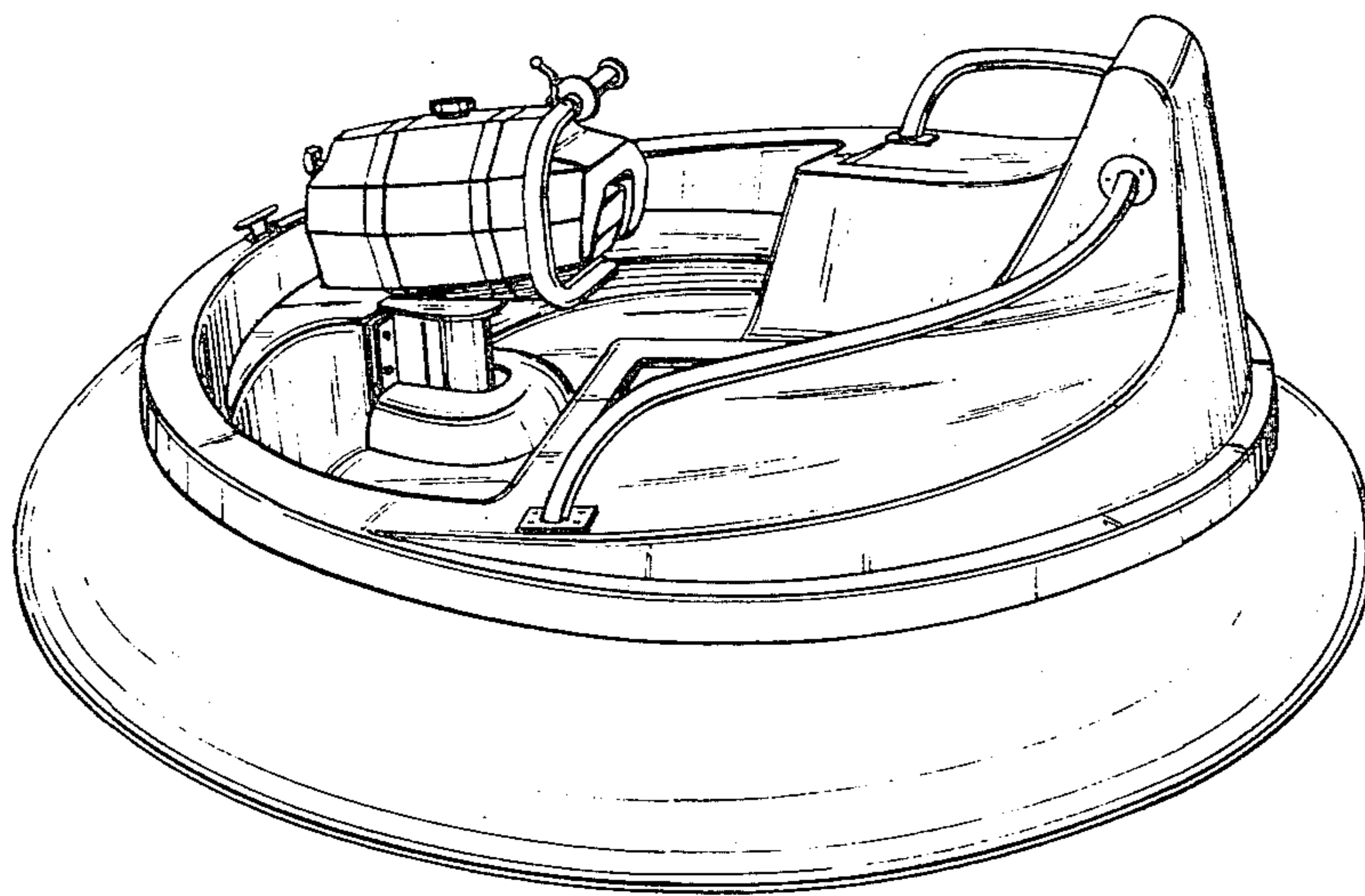
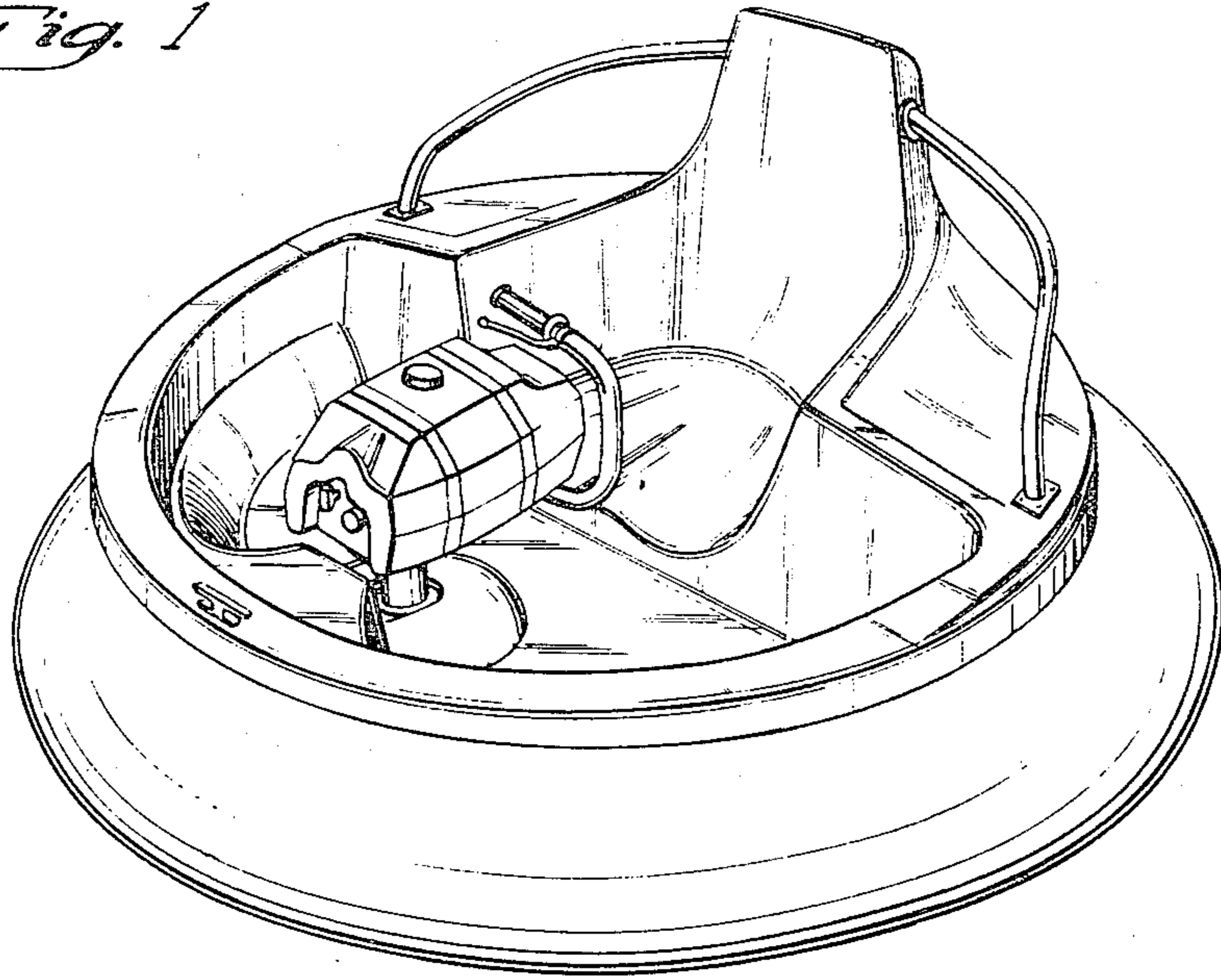
FIG. 1 is a perspective view of the motorized bumper boat, showing our new design;  
 FIG. 2 is another perspective view thereof; taken from a different angle;  
 FIG. 3 is a front elevational view thereof;  
 FIG. 4 is a rear elevational view thereof; and  
 FIG. 5 is a side elevational view thereof.

[56] **References Cited**  
**U.S. PATENT DOCUMENTS**

- D. 197,197 12/1963 Bennett ..... D12/316
- D. 211,499 6/1968 Hofius ..... D12/307
- D. 229,354 11/1973 Morgar ..... D12/316
- D. 235,532 6/1975 Bernard ..... D12/306
- D. 264,707 6/1982 Bettis ..... D12/309

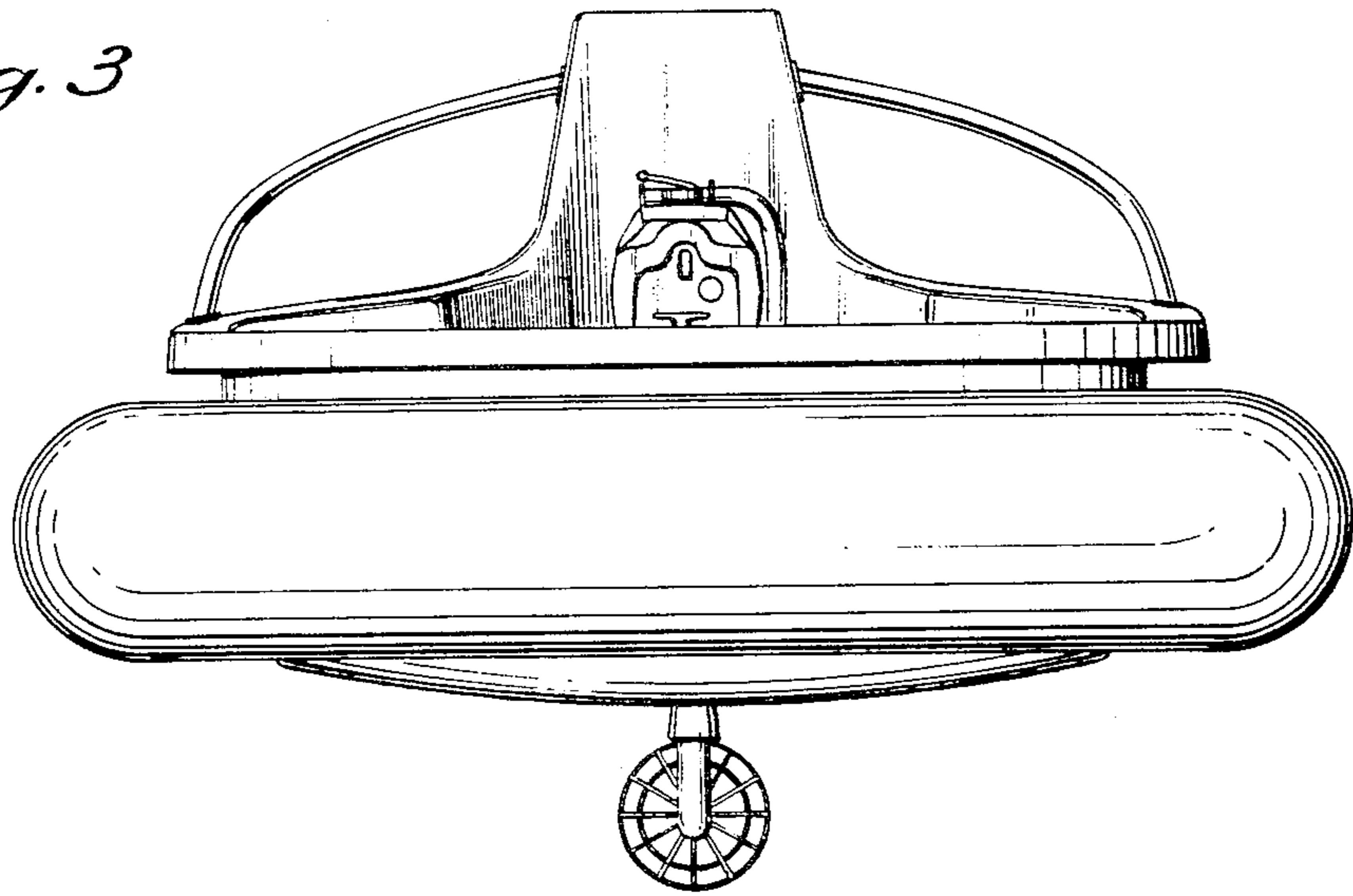


*Fig. 1*

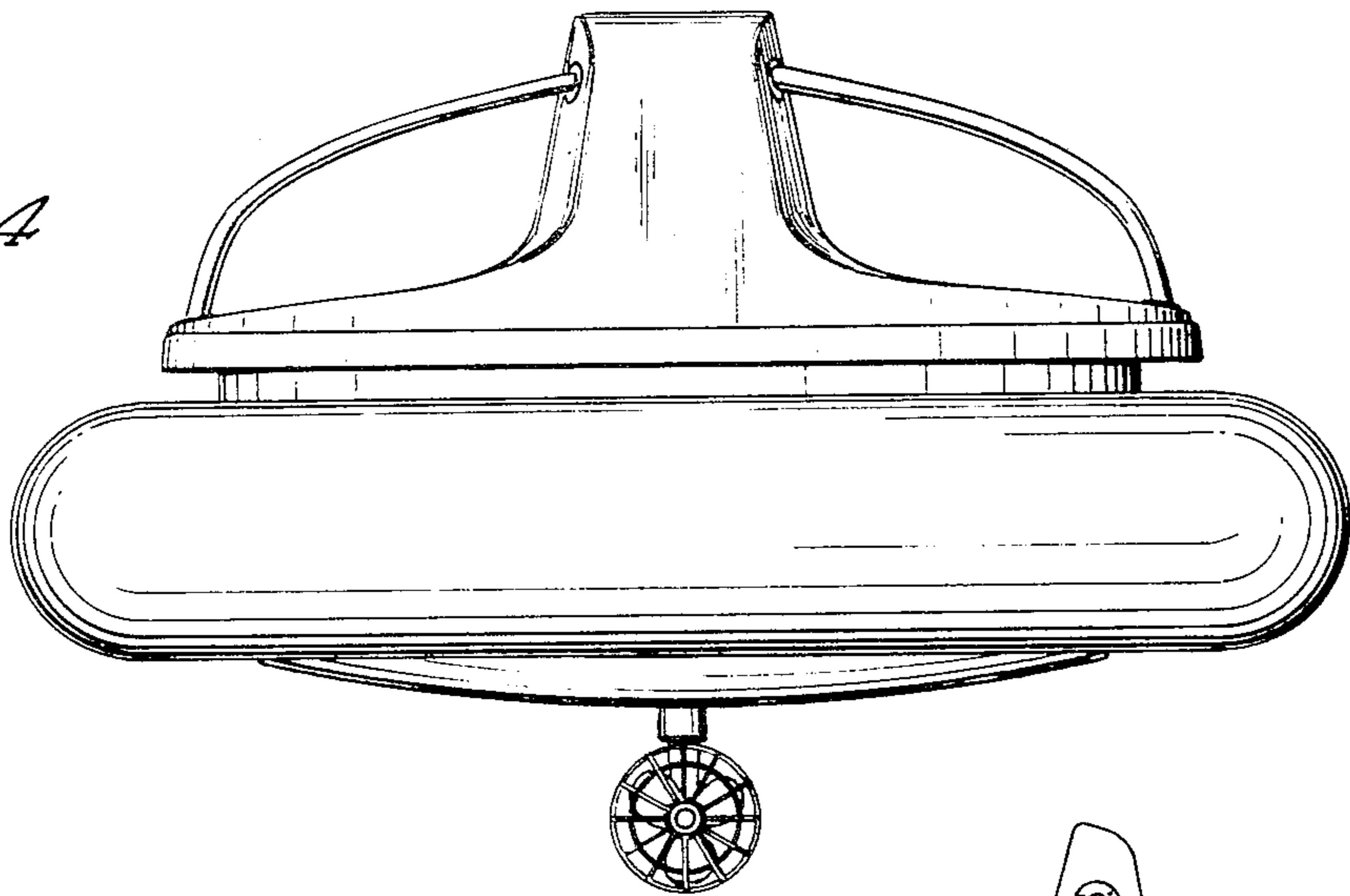


*Fig. 2*

*Fig. 3*



*Fig. 4*



*Fig. 5*

