

[54] MOTORCYCLE

[75] Inventors: Masato Iwakura; Yasuaki Ohshima, both of Asaka; Masamoto Ito, Komae, all of Japan

[73] Assignee: Honda Giken Kogyo Kabushiki Kaisha, Tokyo, Japan

[**] Term: 14 Years

[21] Appl. No.: 450,729

[22] Filed: Dec. 17, 1982

[30] Foreign Application Priority Data

Jun. 22, 1982 [JP] Japan 57-28085
[52] U.S. Cl. D12/110
[58] Field of Search D12/110; 180/219

[56] References Cited

U.S. PATENT DOCUMENTS

D. 267,638 1/1983 Iwasaki D12/110

OTHER PUBLICATIONS

Cycle World, 9/81, p. 24, Kawasaki KZ 750, bottom center of page.
Cycle World, 2/80, p. 79, Honda CX 500.
Cycle World, 5/81, p. 49, Honda Motorcycle, bottom of page.
Cycle World, 6/81, p. 45, Yamaha 750 Seca.
Extract from the enlarged issue of Japanese magazine entitled "Motorcyclist", Apr. 1, 1982, p. 79.

Primary Examiner—James M. Gandy
Attorney, Agent, or Firm—Armstrong, Nikaido, Marmelstein & Kubovcik

[57] CLAIM

The ornamental design for a motorcycle, as shown and described.

DESCRIPTION

FIG. 1 is a right side elevational view of a motorcycle, showing our new design;
FIG. 2 is a left side elevational view thereof;
FIG. 3 is a front elevational view thereof;
FIG. 4 is a rear elevational view thereof;
FIG. 5 is a top plan view thereof;
FIG. 6 is a bottom plan view thereof;
FIG. 7 is a perspective view thereof.

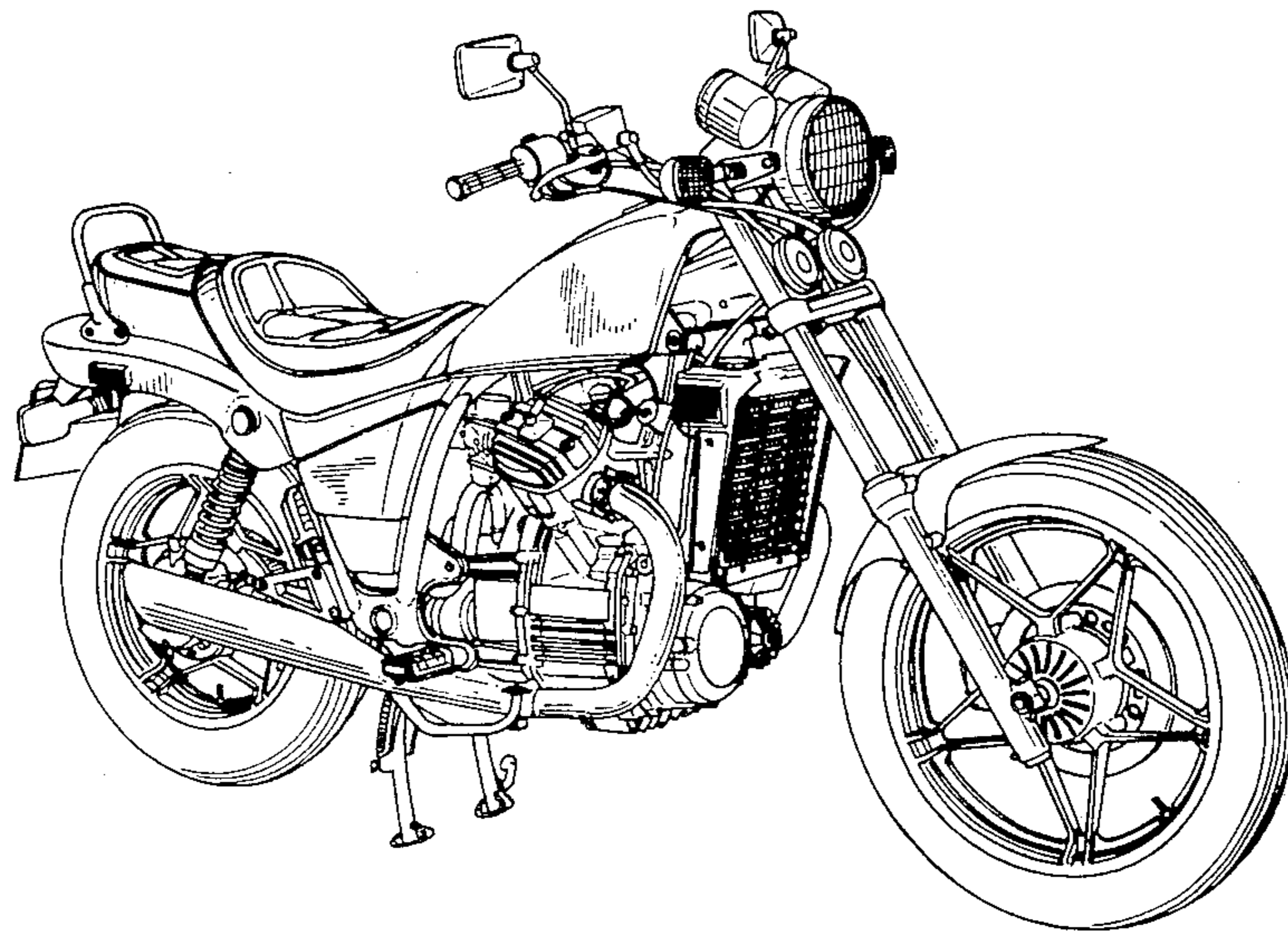

FIG. 1

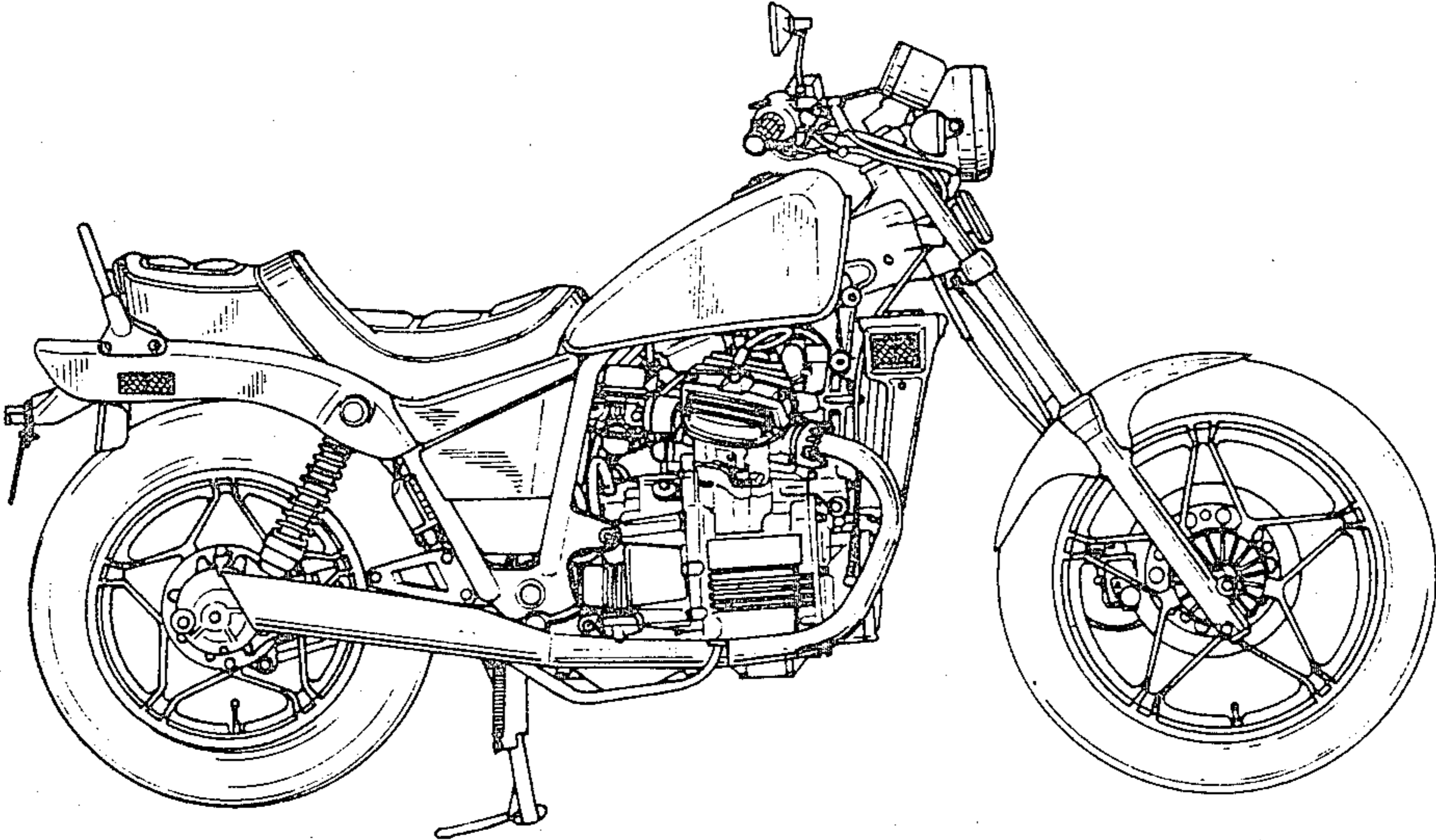

FIG. 2

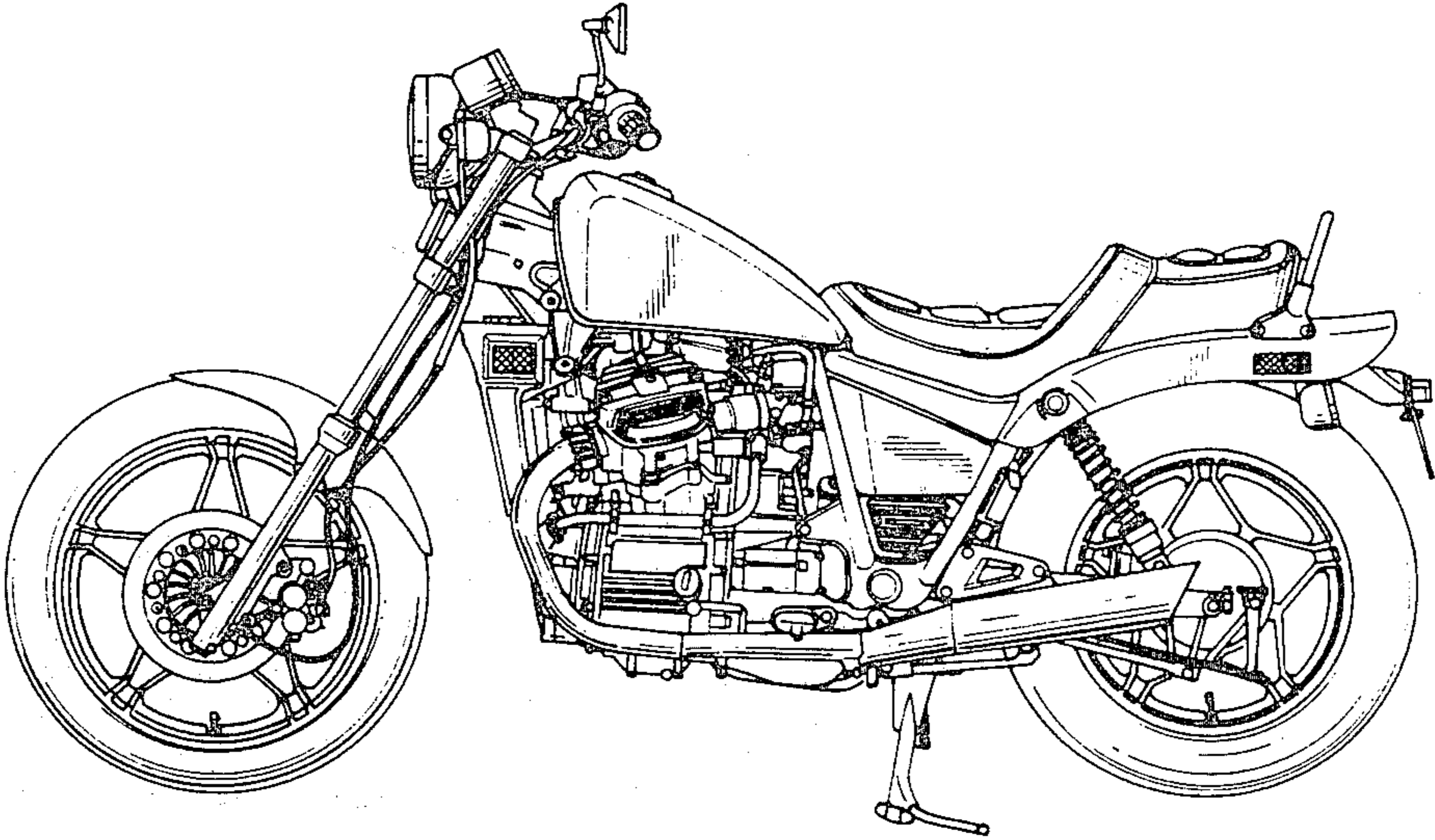

FIG.3

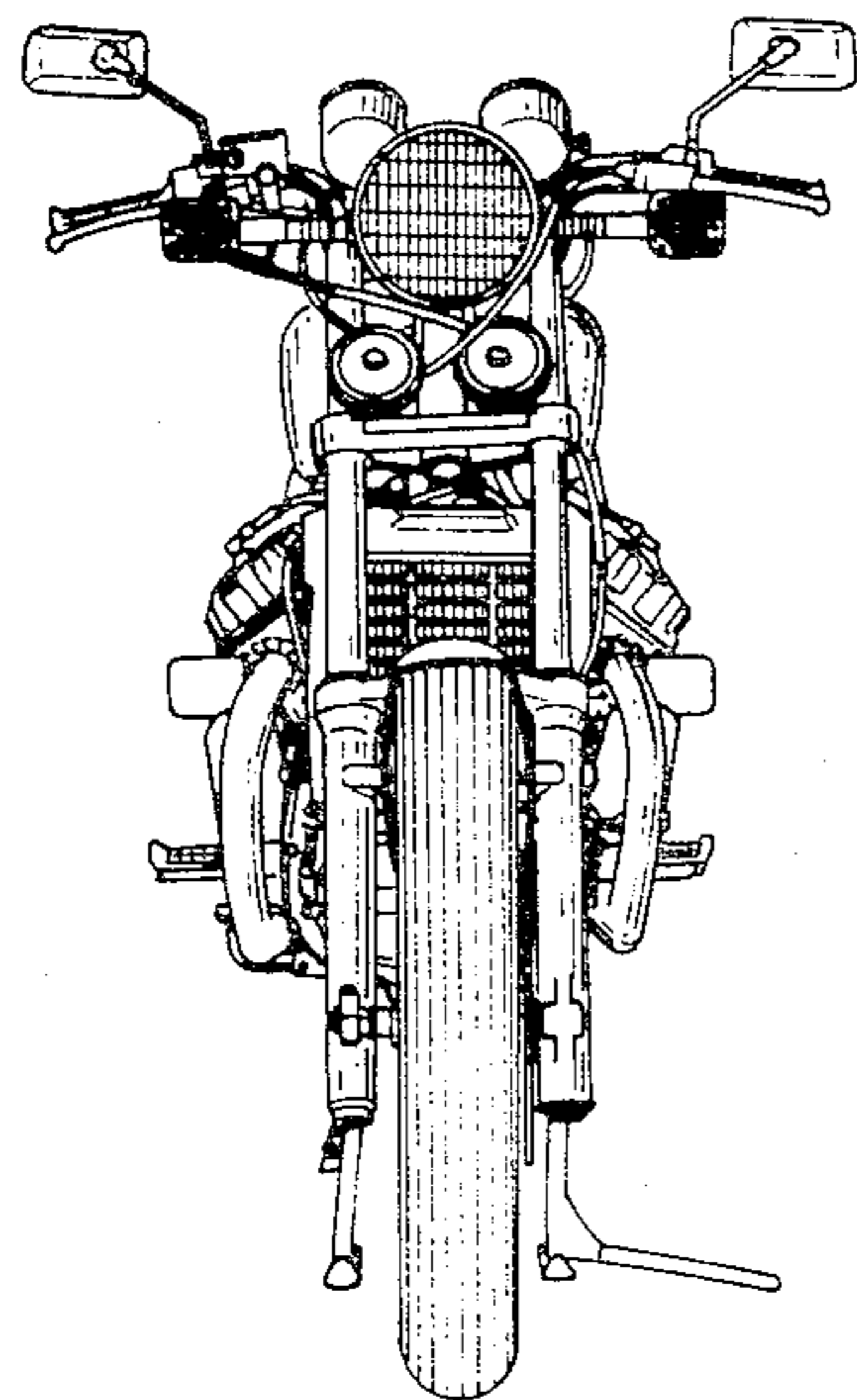

FIG.4

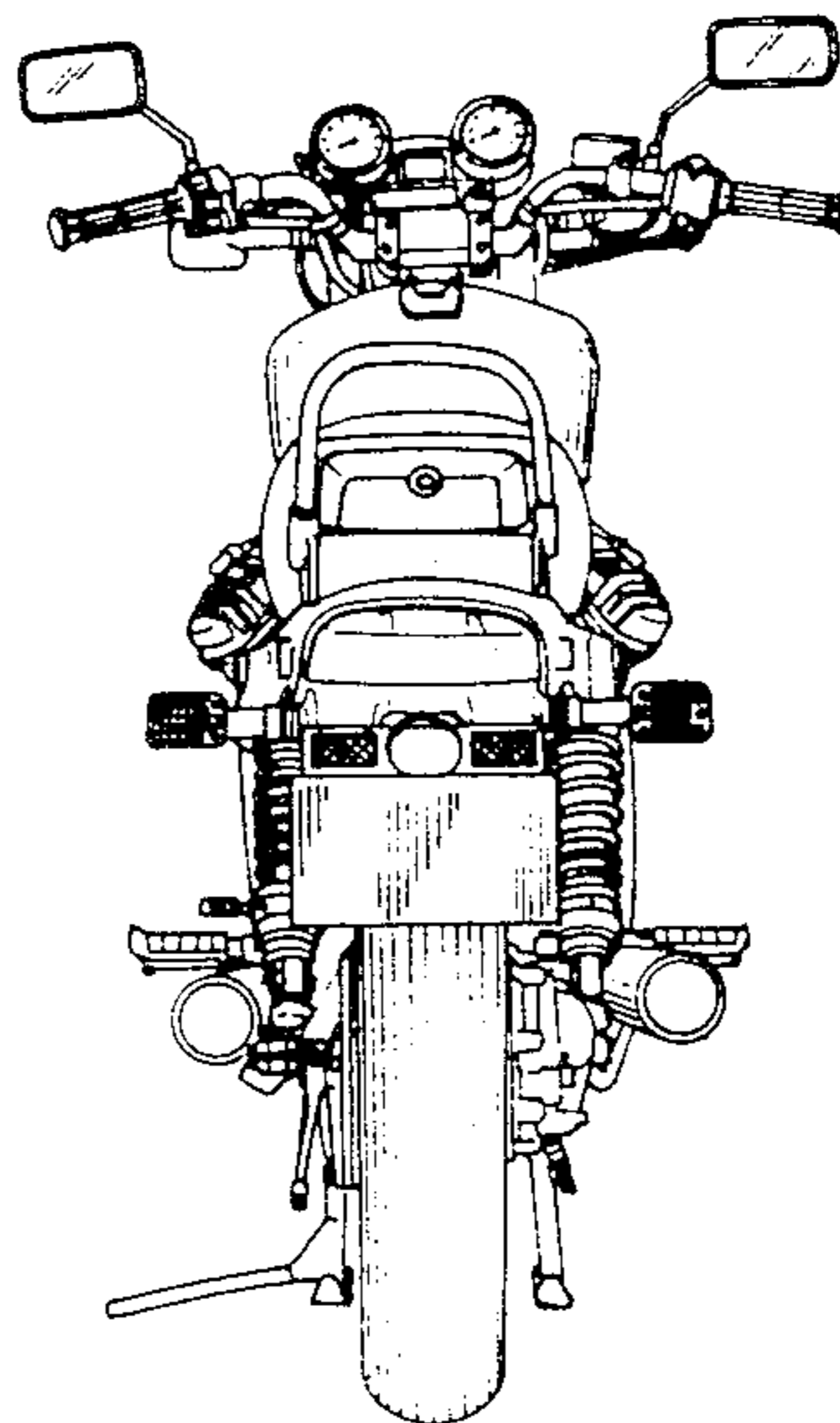

FIG.5

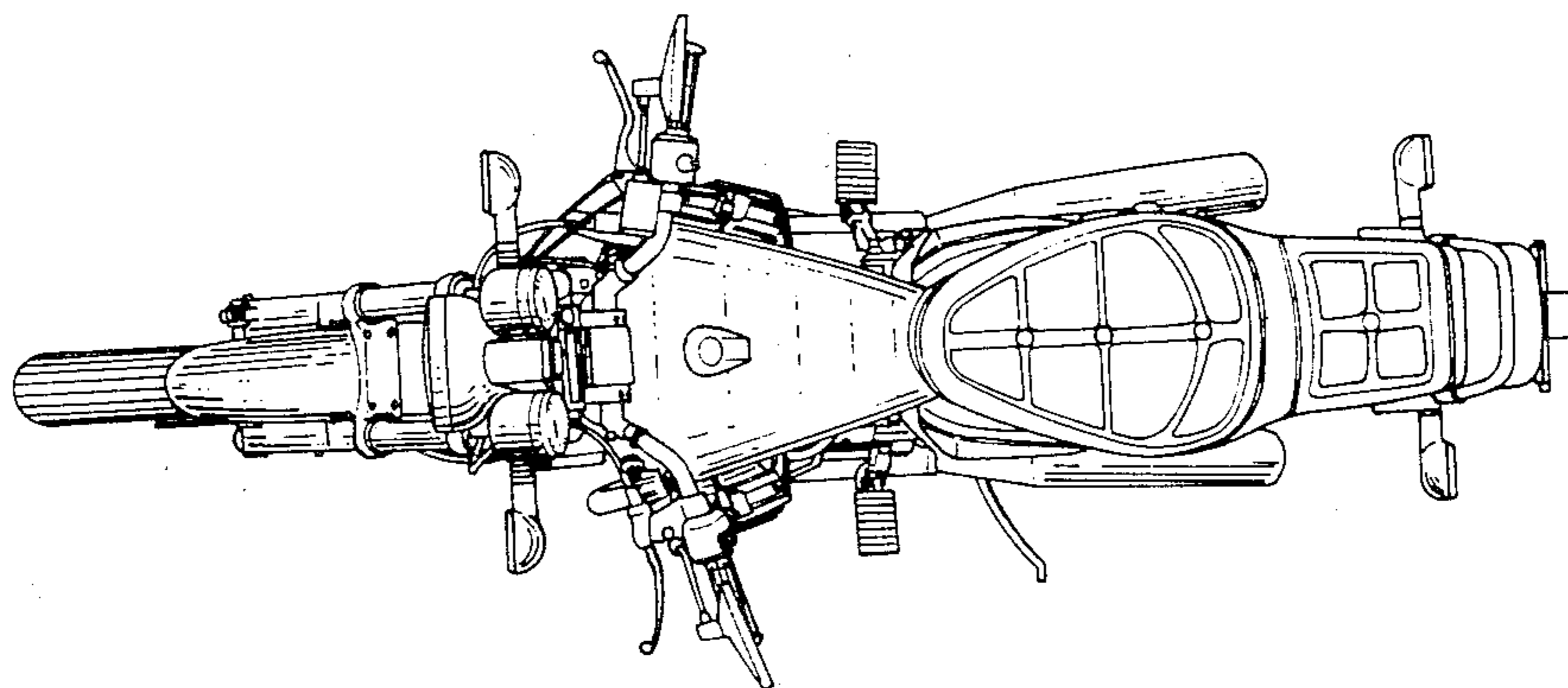

FIG. 6

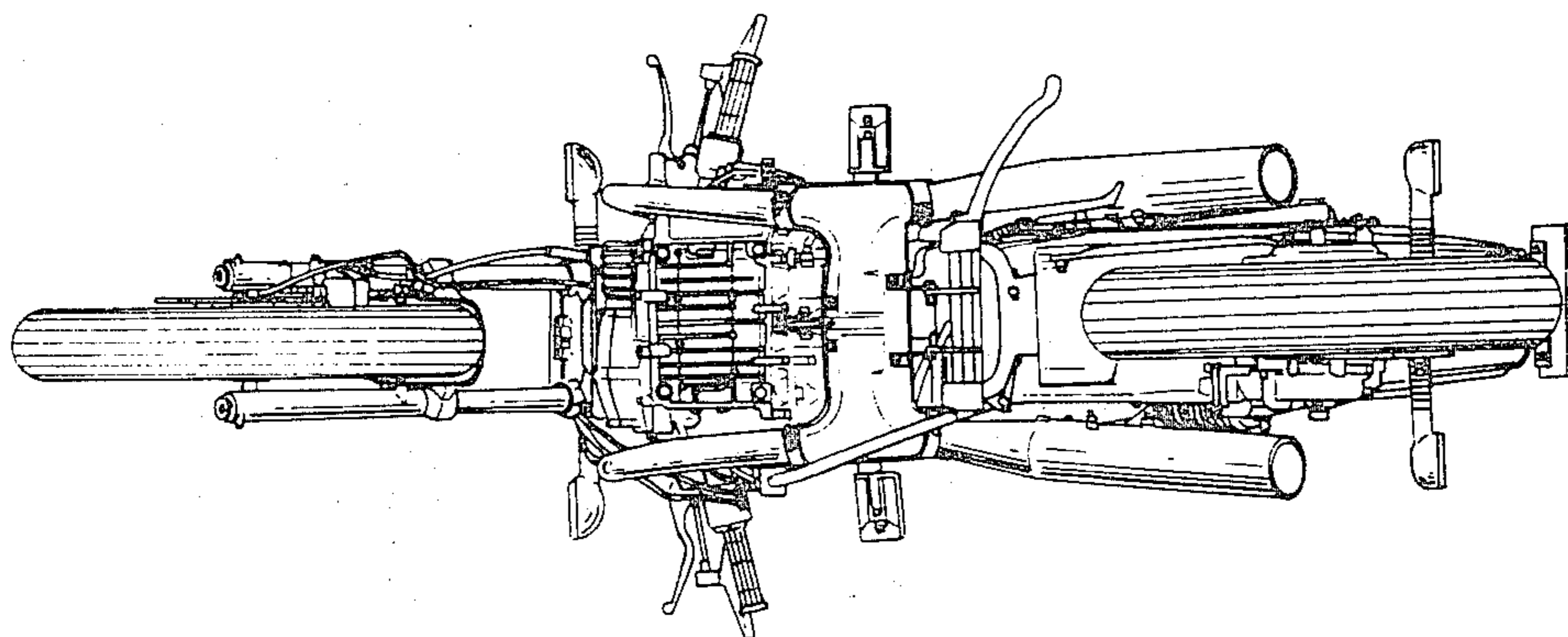

FIG. 7

