

[54] COMBINED CONVEYOR CARRIER AND TRACK UNIT

Primary Examiner—James M. Gandy
Attorney, Agent, or Firm—Joseph W. Farley

[75] Inventor: Clarence A. Dehne, Farmington Hills, Mich.

[57] CLAIM

The ornamental design for a combined conveyor carrier and track unit, as shown and described.

[73] Assignee: Jervis B. Webb Company, Farmington Hills, Mich.

DESCRIPTION

[**] Term: 14 Years

FIG. 1 is a side elevation view of a combined conveyor carrier and track unit embodying my design the opposite side being a mirror image thereof;

[21] Appl. No.: 255,114

FIG. 2 is a top plan view thereof;

[22] Filed: Apr. 17, 1981

FIG. 3 is an end elevation view thereof; and

[52] U.S. Cl. D34/29

FIG. 4 is an end elevation view of the end thereof opposite to that shown in FIG. 3.

[58] Field of Search D34/29; 104/172 B

The combined conveyor carrier and track unit has been broken away in the middle to indicate indeterminate length.

[56] References Cited

FOREIGN PATENT DOCUMENTS

55-40145 3/1980 Japan 104/172 B

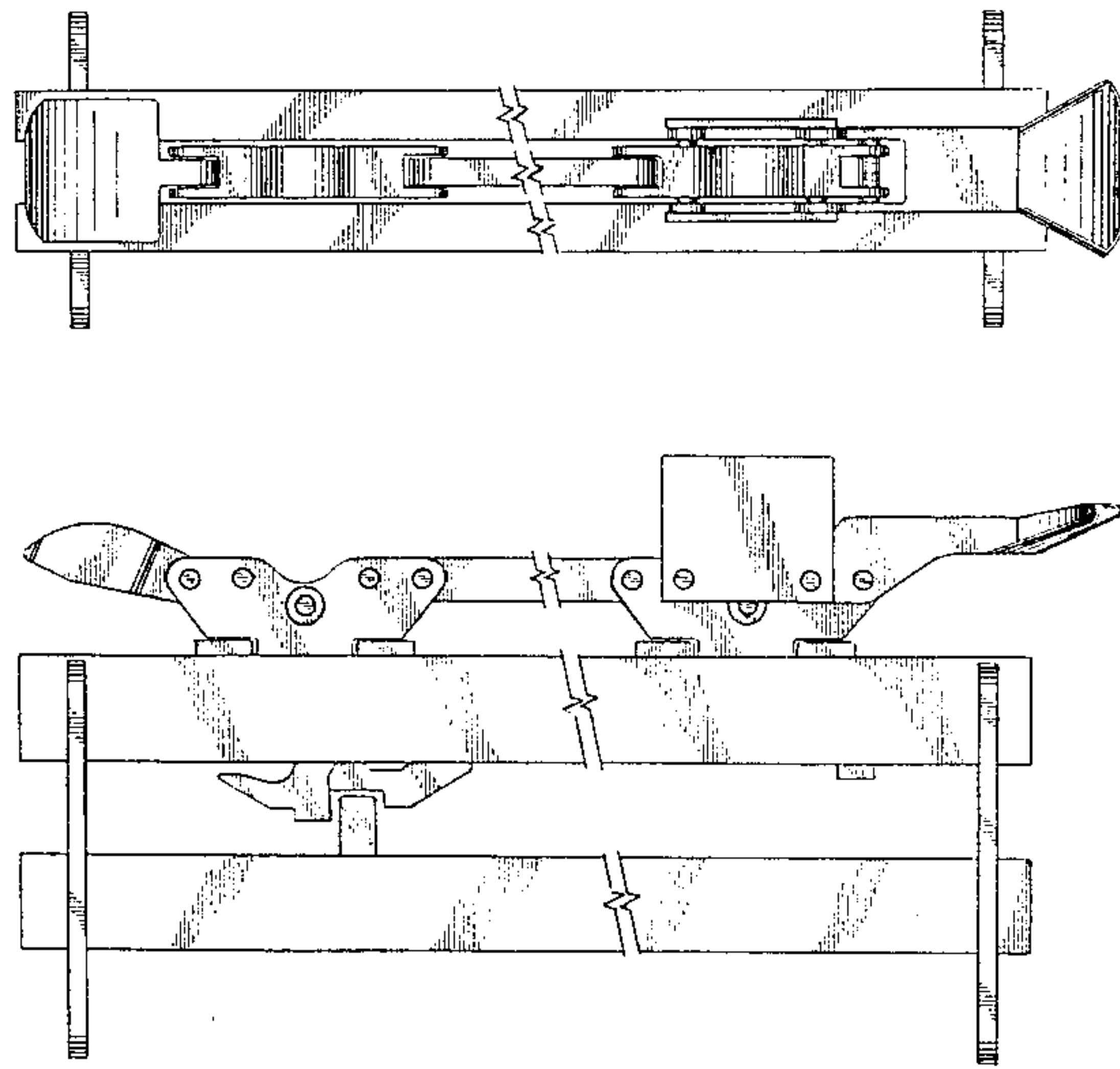

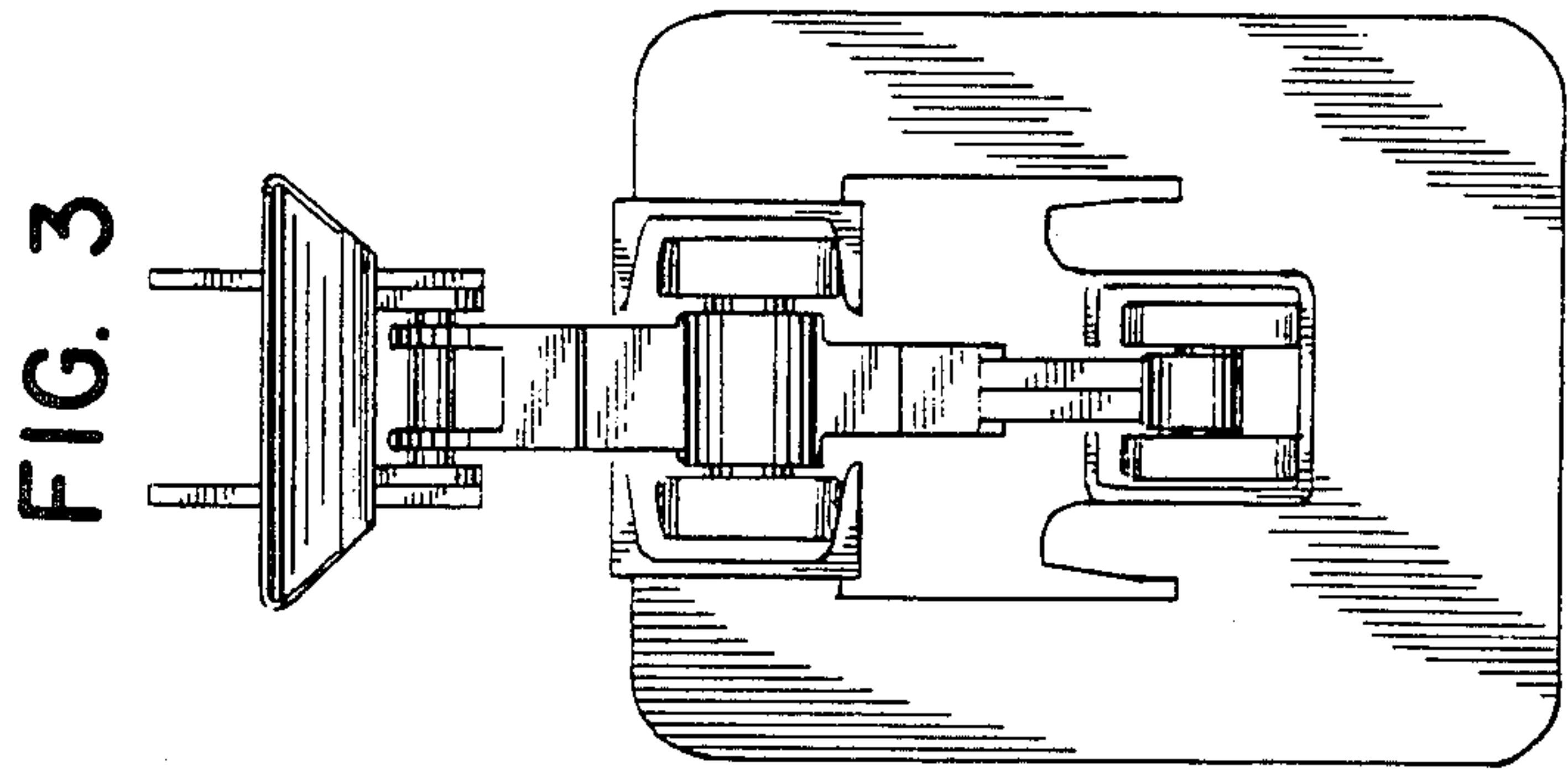
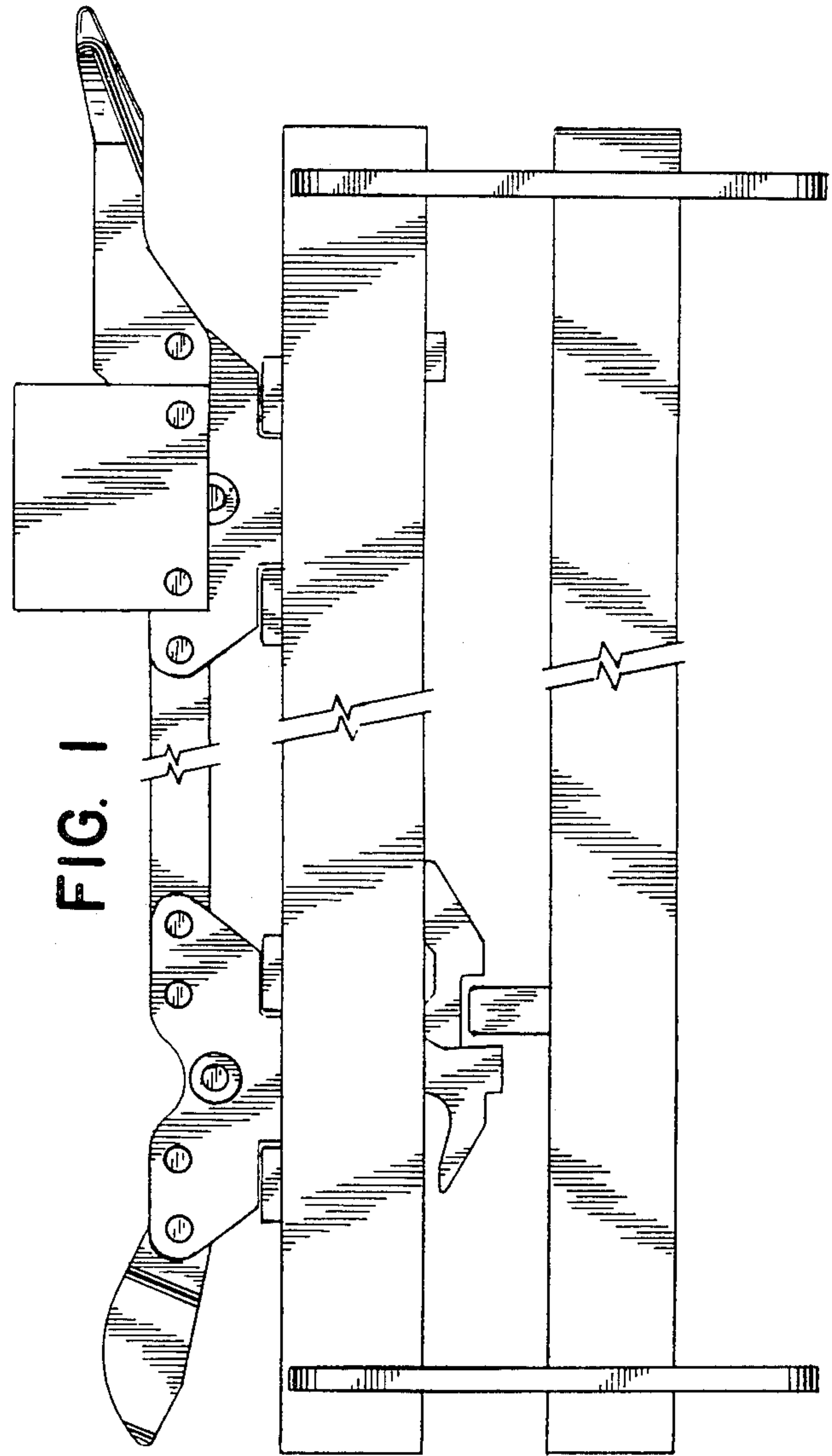
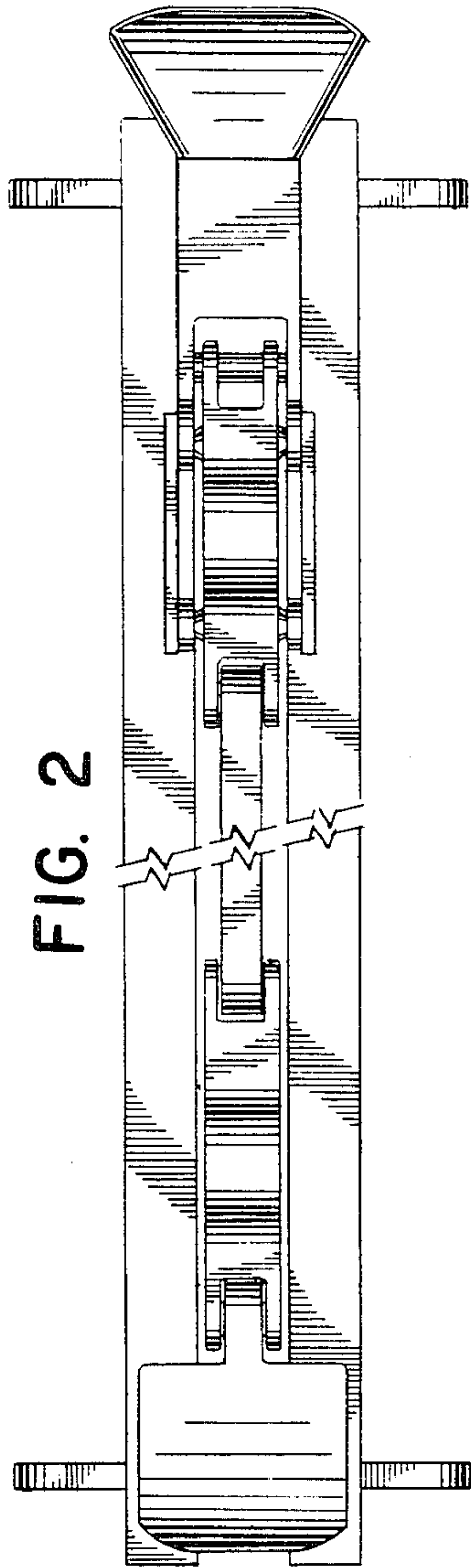

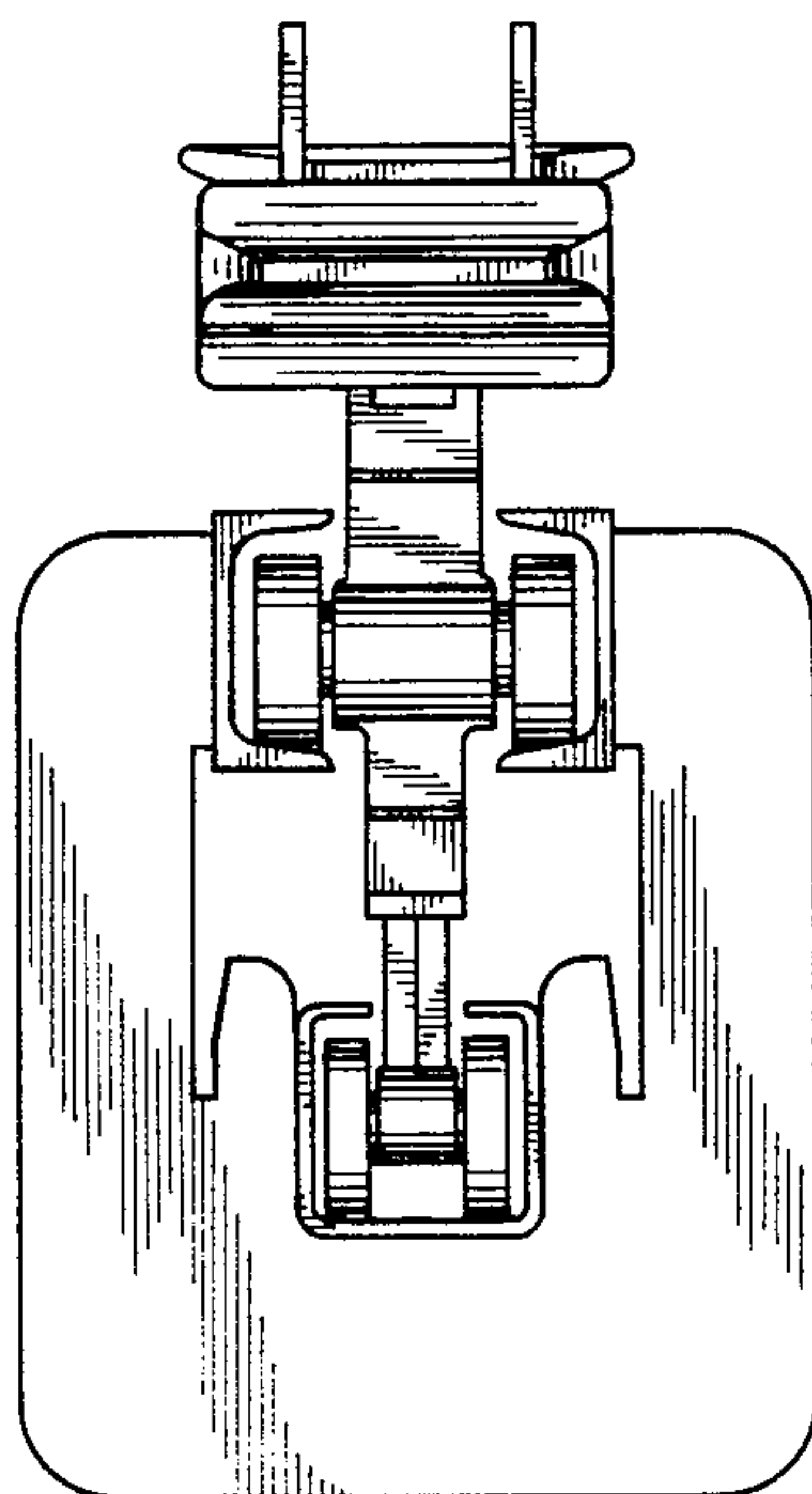

FIG. 4