

[54] AIRPLANE

[76] Inventor: Anthony F. Drake, 504 Terrace, Pullman, Wash. 99163

[\*\*] Term: 14 Years

[21] Appl. No.: 356,375

[22] Filed: Mar. 9, 1982

[52] U.S. Cl. .... D12/339; D12/342

[58] Field of Search ..... D12/339, 342

[56] References Cited

U.S. PATENT DOCUMENTS

D. 150,692	8/1948	Glasgow et al. ....	D12/339
D. 179,348	12/1956	Johnson .....	D12/342 X
D. 183,675	10/1958	Begin, Jr. et al. ....	D12/342
D. 191,019	8/1961	Thieblot .....	D12/342 X

OTHER PUBLICATIONS

Interavia, 9/80, p. 753, Lear Fan Aircraft at top right of page.

Interavia, 2/80, p. 128, Aircraft at No. 3 in group at top left of page.

Primary Examiner—Alan P. Douglas  
Attorney, Agent, or Firm—Hugh D. Jaeger

[57] CLAIM

The ornamental design for an airplane, as shown.

DESCRIPTION

FIG. 1 is a top view of the airplane, the present invention;

FIG. 2 is a port side view;

FIG. 3 is a starboard side view;

FIG. 4 is a bottom view;

FIG. 5 is a nose view, and;

FIG. 6 is a tail view.

The broken line disclosure of a propeller path is for illustrative purposes only.

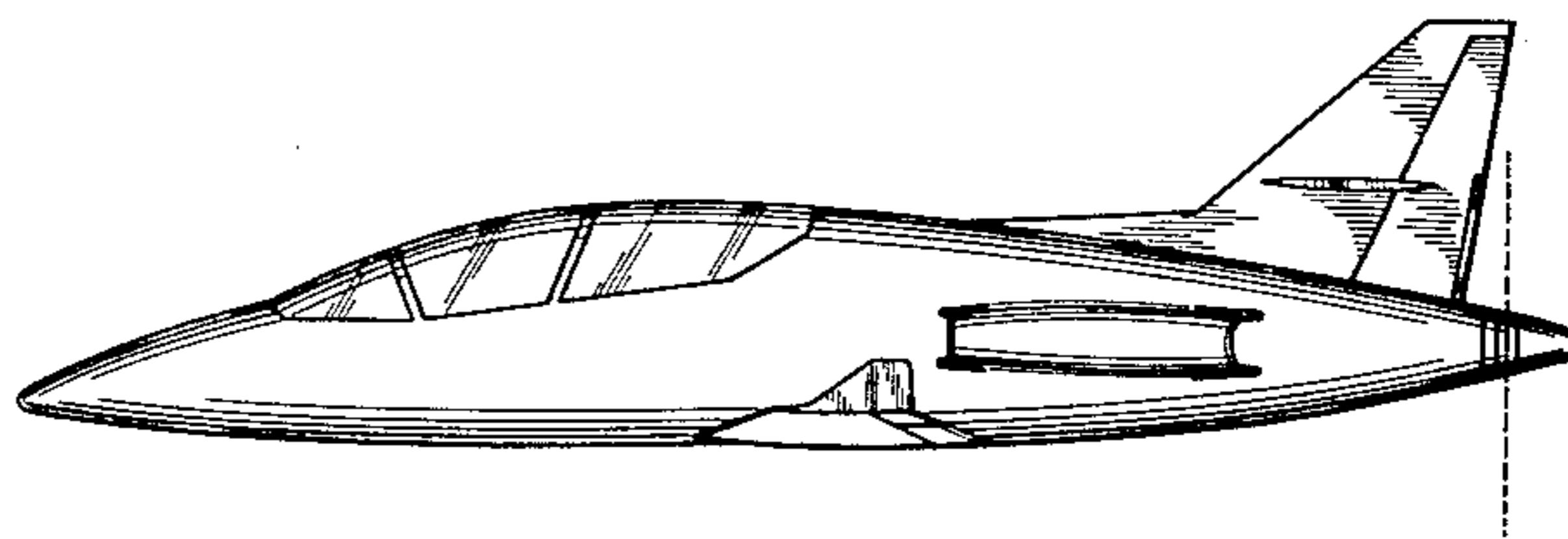
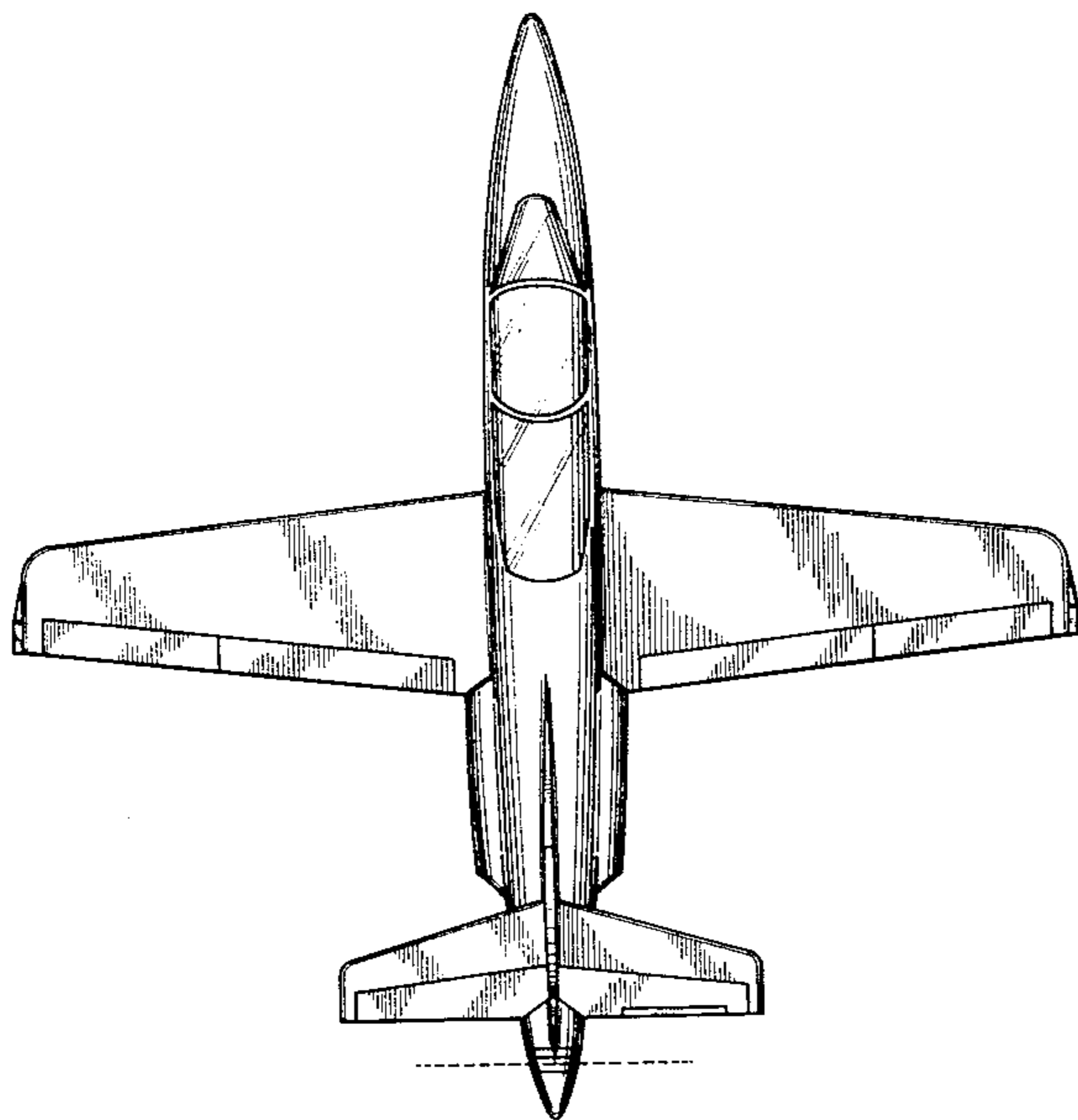

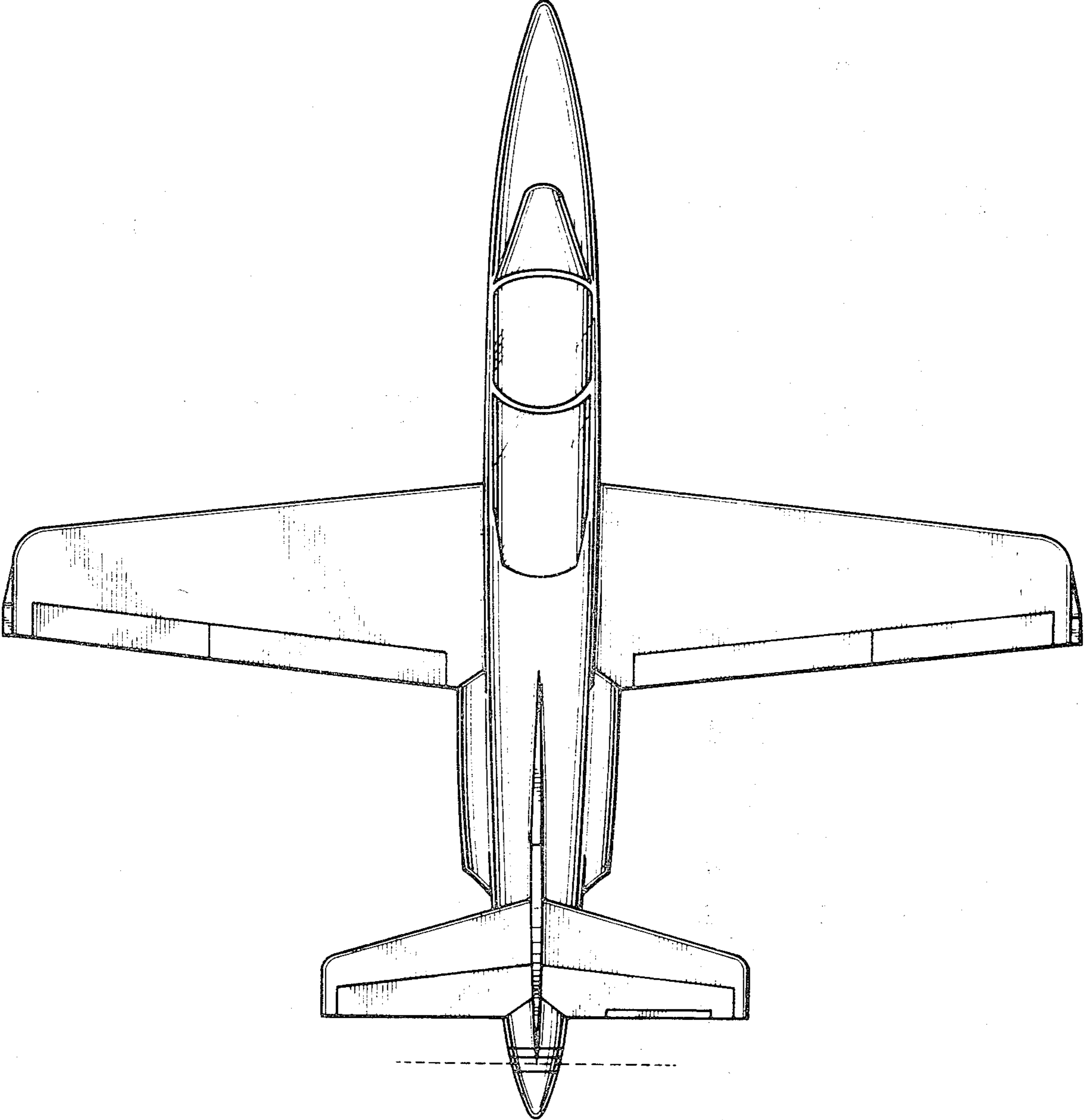

FIG. 1

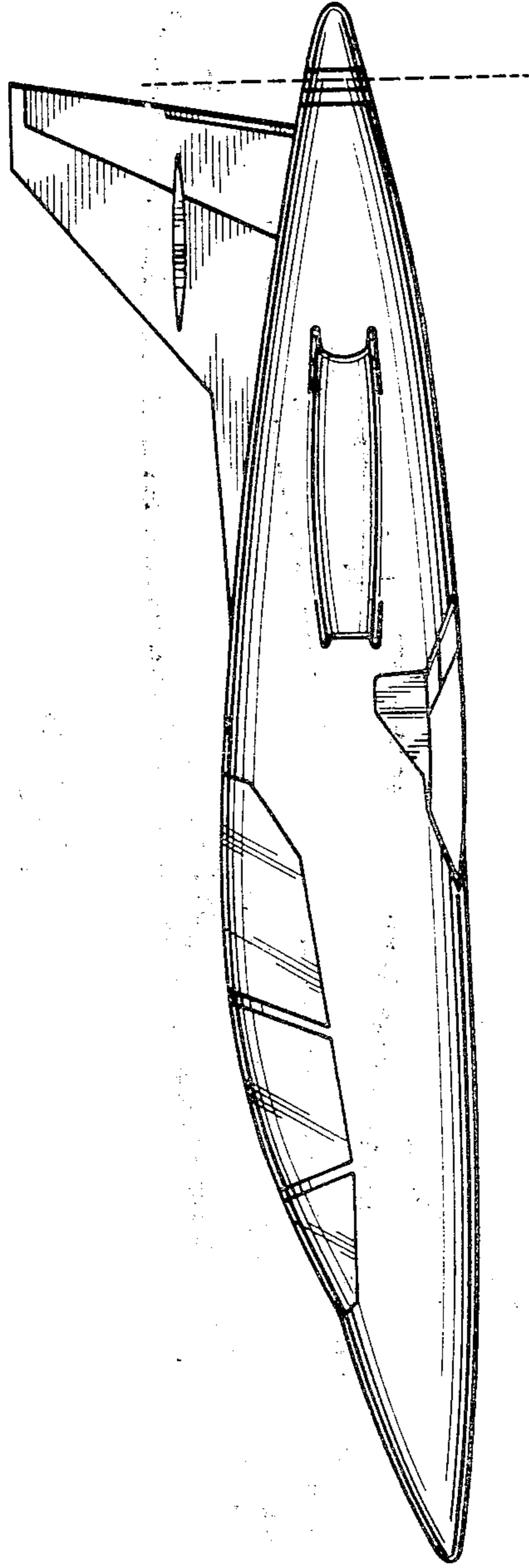

FIG. 2

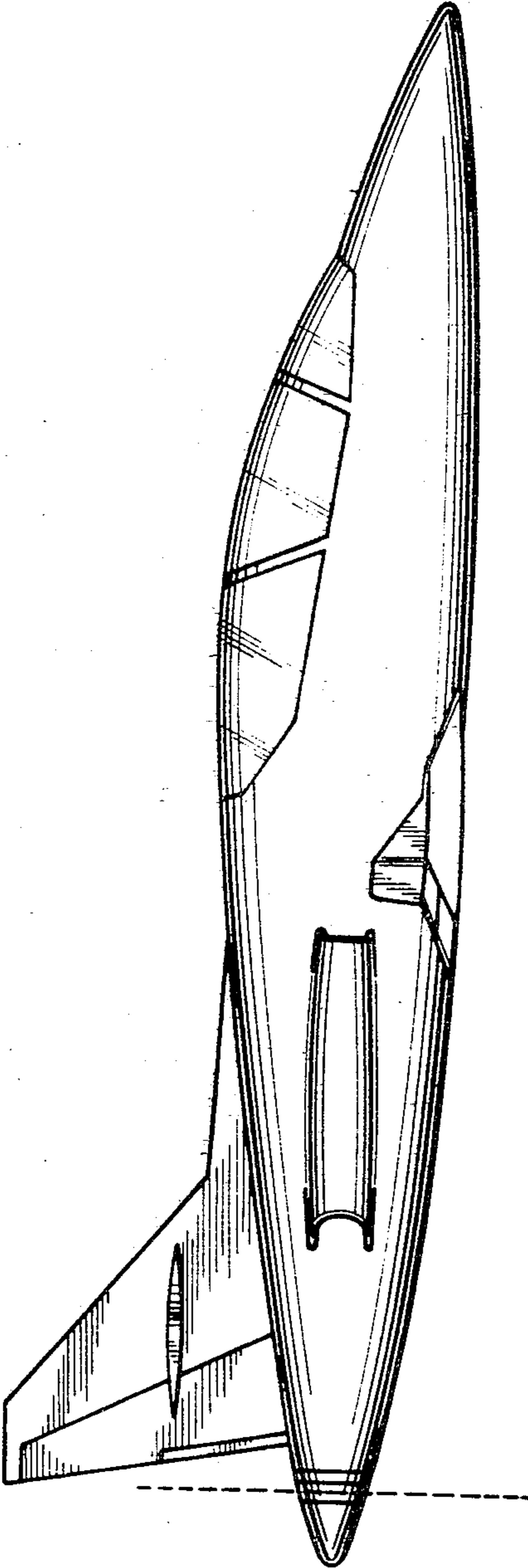

FIG. 3

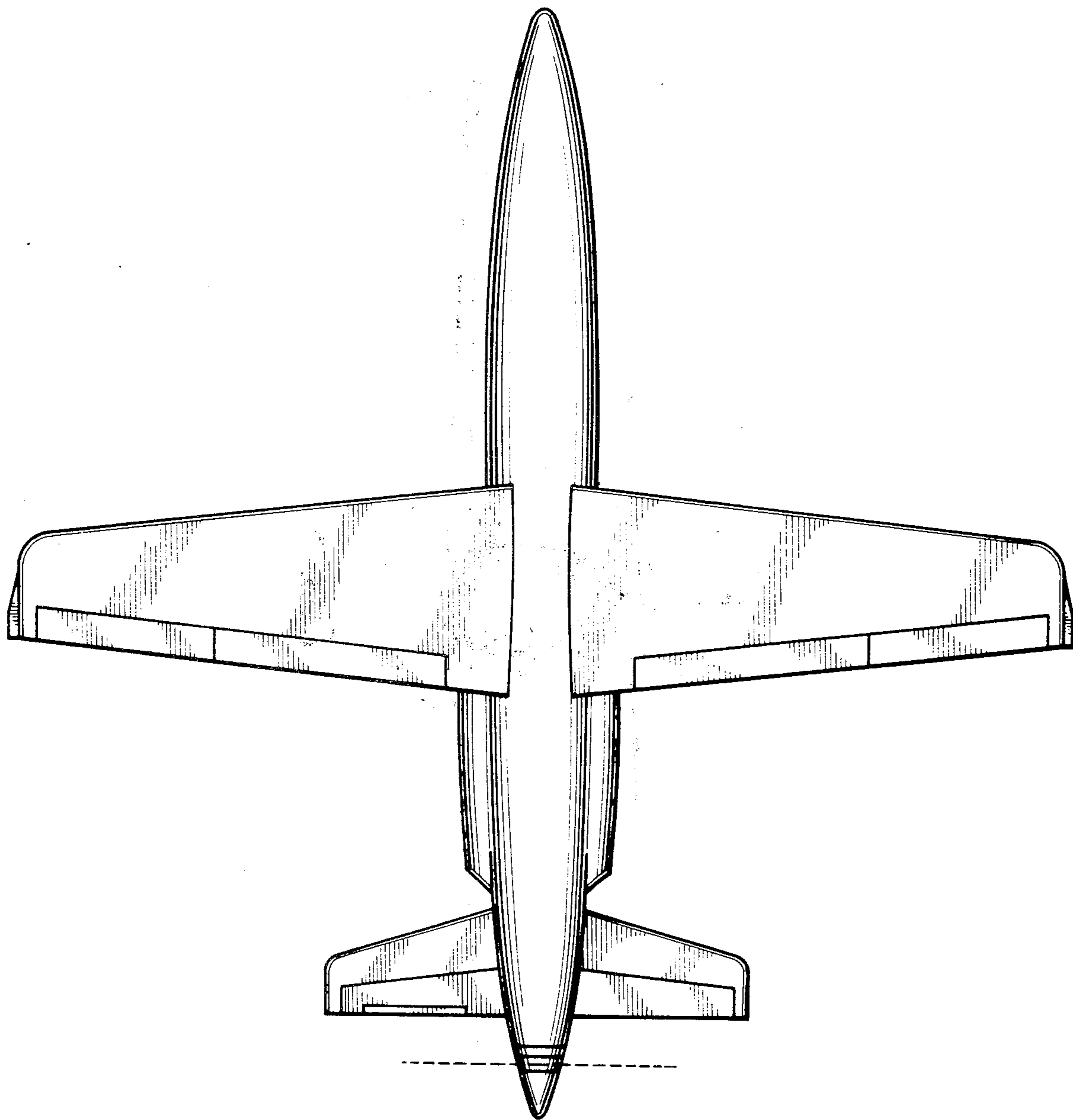

FIG. 4

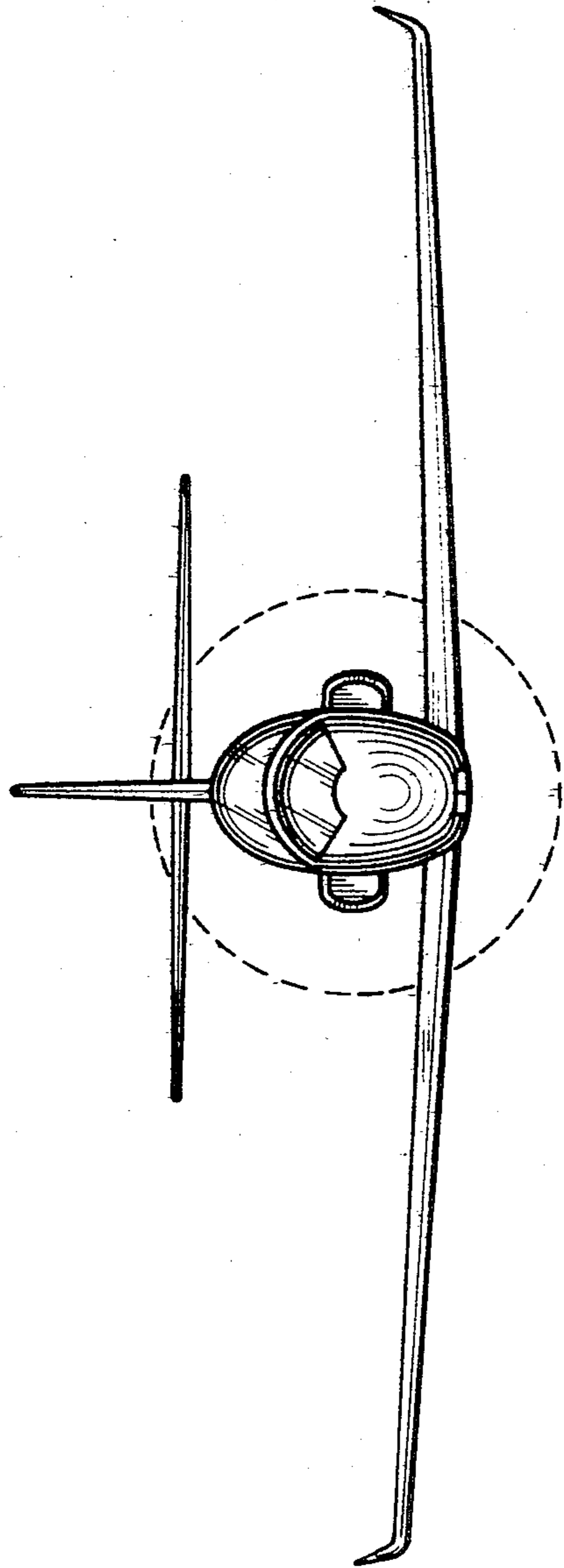

FIG. 5

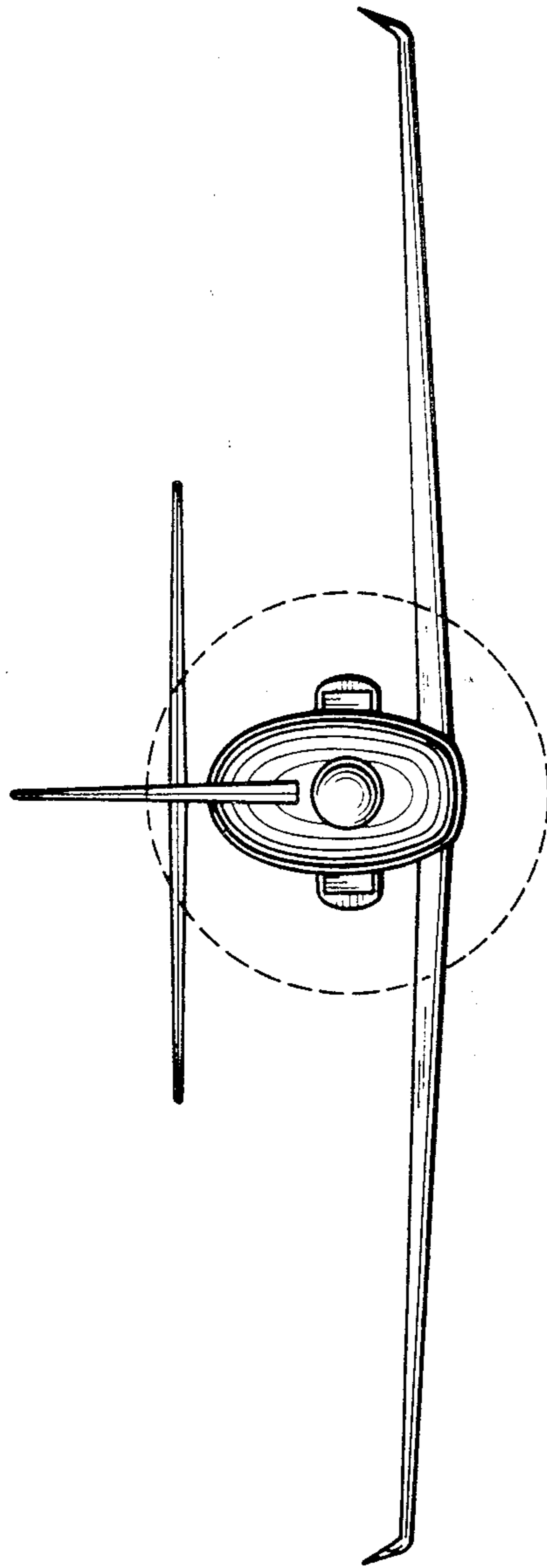

FIG. 6