

[54] VEHICLE WHEEL CENTER

[75] Inventor: Raymond J. Hedlund, Concord, Calif.

[73] Assignee: Kelsey-Hayes Co., Romulus, Mich.

[**] Term: 14 Years

[21] Appl. No.: 372,767

[22] Filed: Apr. 28, 1982

[52] U.S. Cl. D12/211

[58] Field of Search D12/209, 211, 135, 210; 301/63 R, 64 R, 65, 66, 64 SD

[56] References Cited

U.S. PATENT DOCUMENTS

D. 85,952	1/1932	Miller	D12/135
D. 204,256	4/1966	Rader	D12/211
D. 204,669	5/1966	Goodwin	D12/209
D. 206,432	12/1966	Reid	D12/209
D. 213,314	2/1969	Reid	D12/209
D. 231,732	6/1974	Ishibashi	D12/209

OTHER PUBLICATIONS

American Bicyclist & Motorcyclist, 4/81, p. 93, sprocket wheel, center of page.

Primary Examiner—James M. Gandy
Attorney, Agent, or Firm—Ralph J. Skinkiss; David L. Kuhn

[57] CLAIM

The ornamental design for a vehicle wheel center, substantially as shown and described.

DESCRIPTION

FIG. 1 is a perspective view of a vehicle wheel center showing my new design, it being understood that the broken lines are for illustrative purposes only.

FIG. 2 is a front elevational view thereof.

FIG. 3 is a sectional view taken along line 3—3 in FIG. 2 with the bolt assembly omitted for donvenience of illustration.

FIG. 4 is a sectional view taken along line 4—4 in FIG. 2.

FIG. 5 is a sectional view taken along line 5—5 in FIG. 2.

FIG. 6 is a sectional view taken along line 6—6 in FIG. 2.

FIG. 7 is a front elevational view of a vehicle wheel center showing a second embodiment of my new design, the sole difference being in the configuration of the five bolt holes.

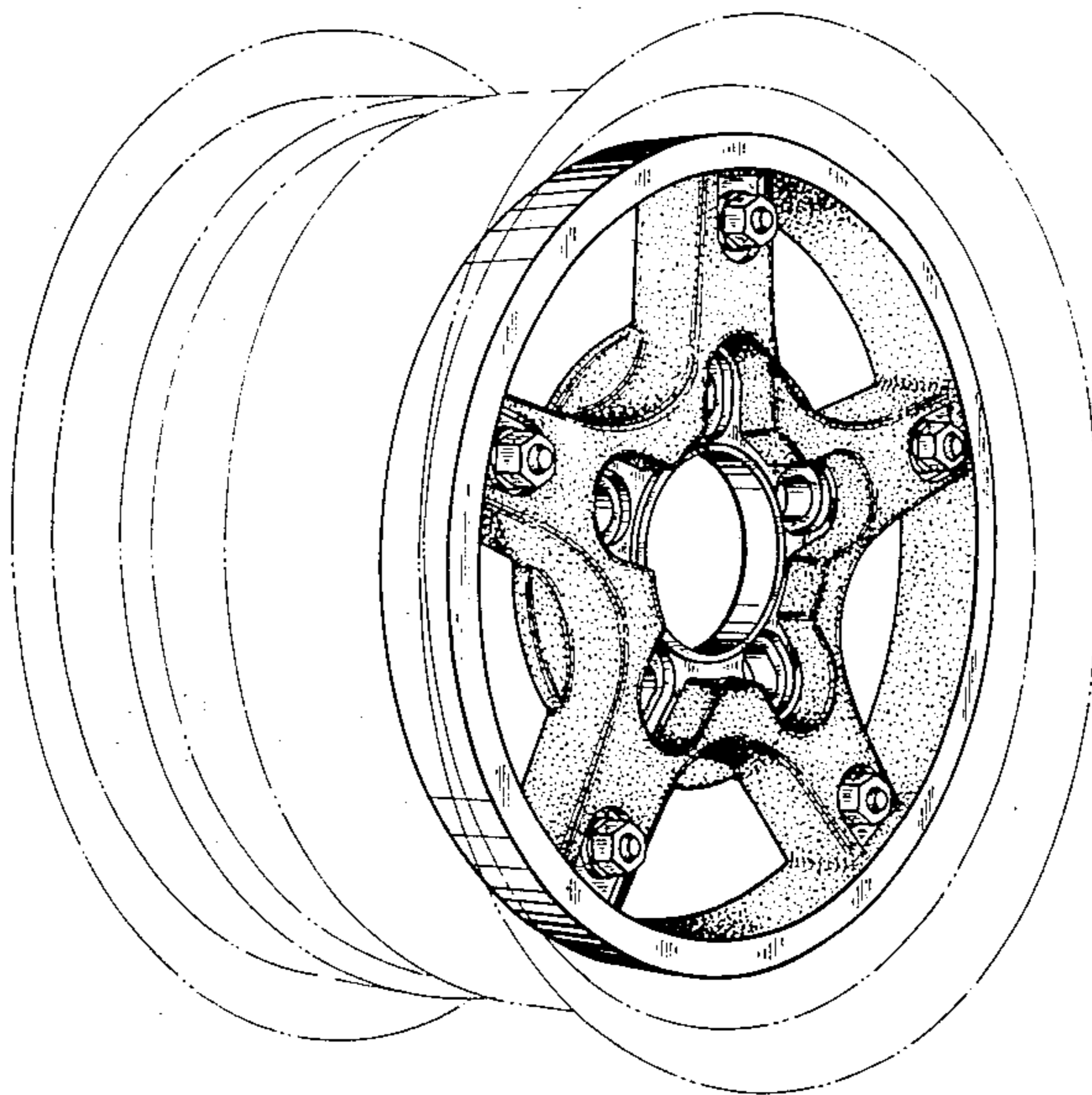

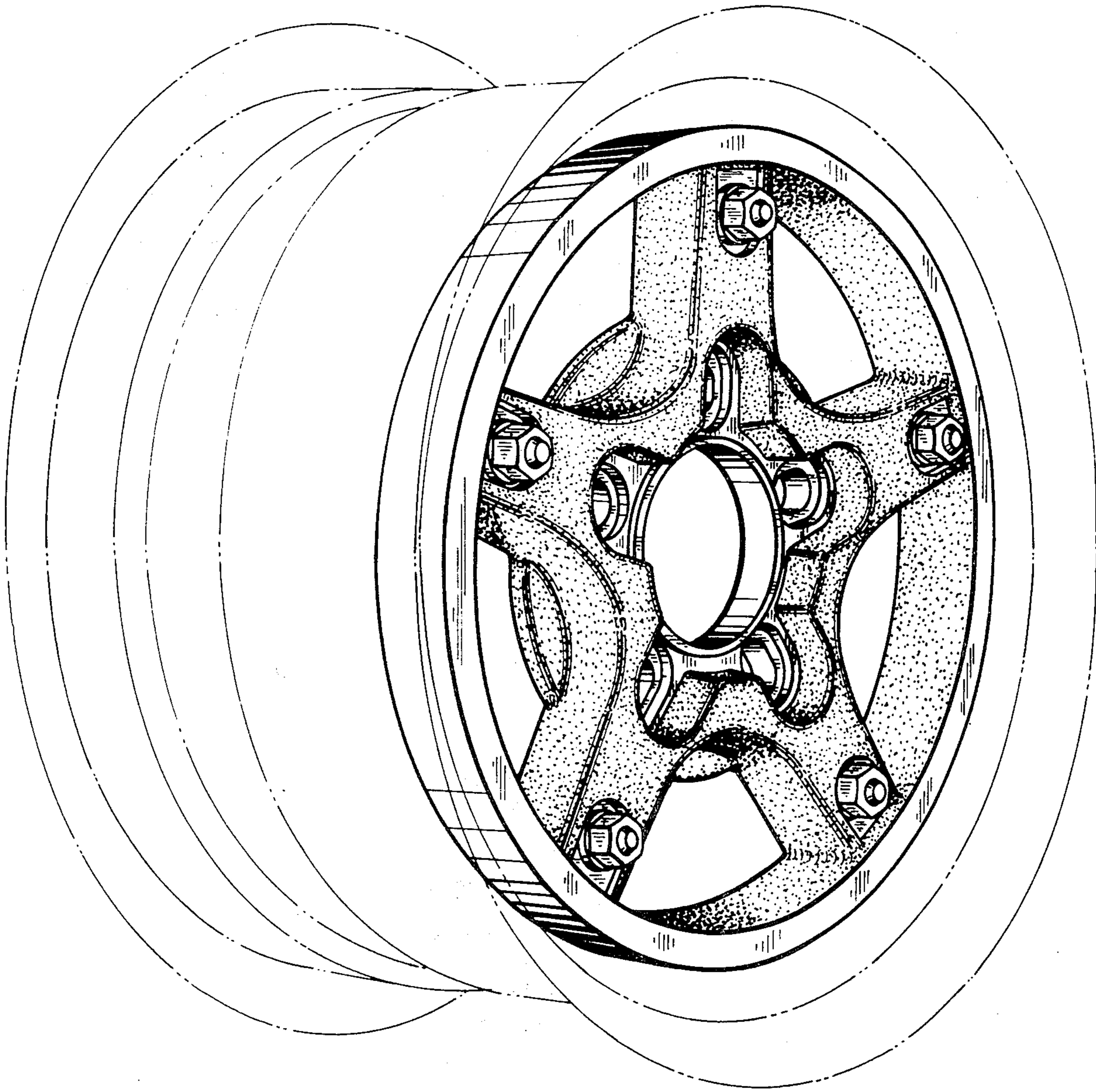

—FIG. 1

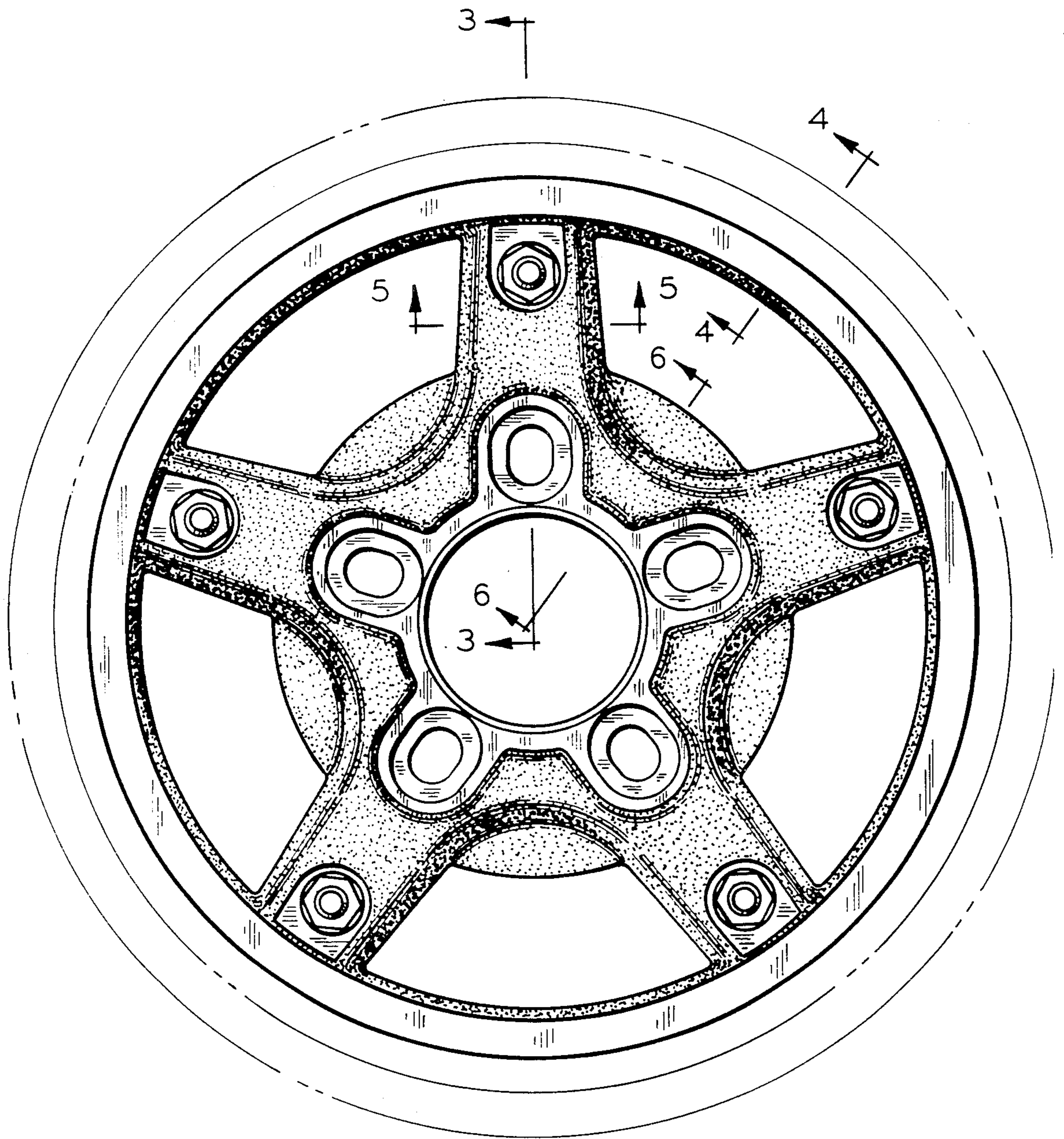

—FIG. 2

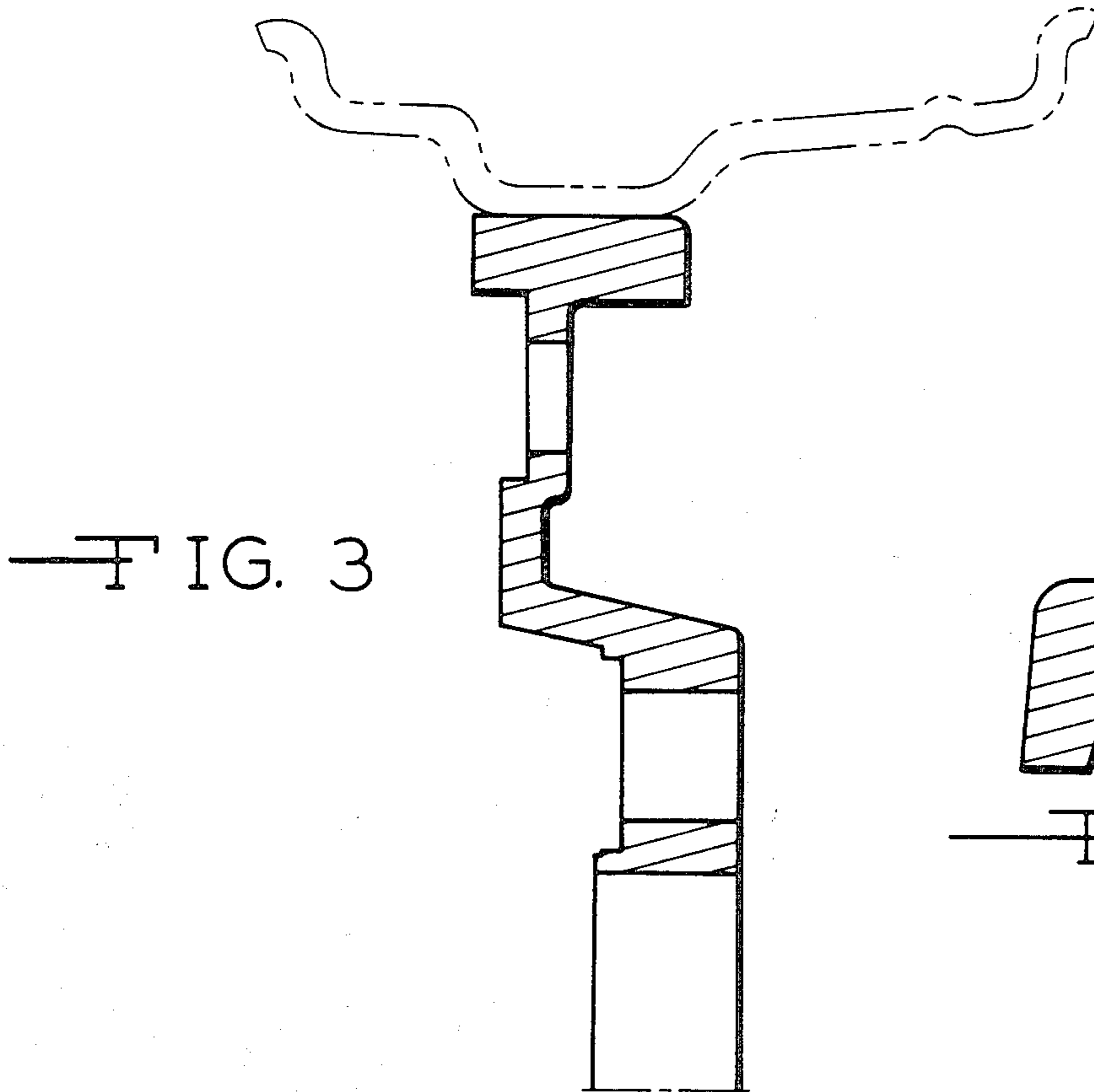

FIG. 3

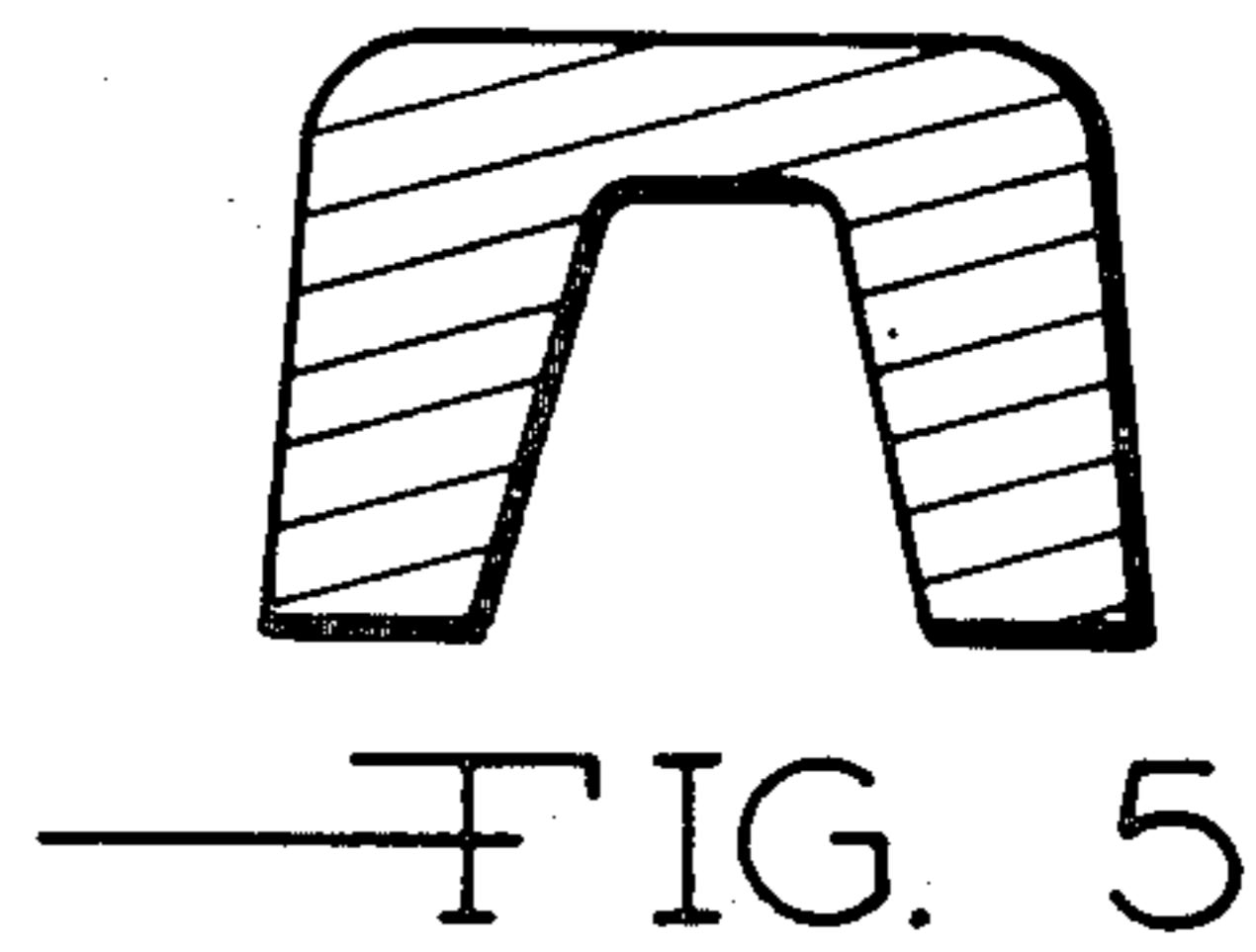

FIG. 5

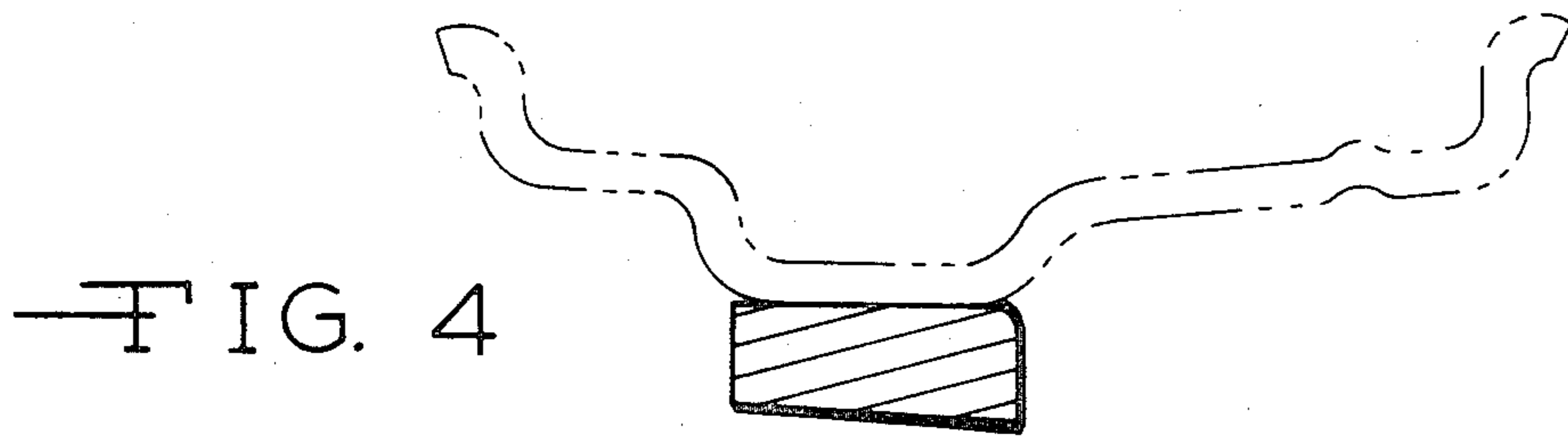

FIG. 4

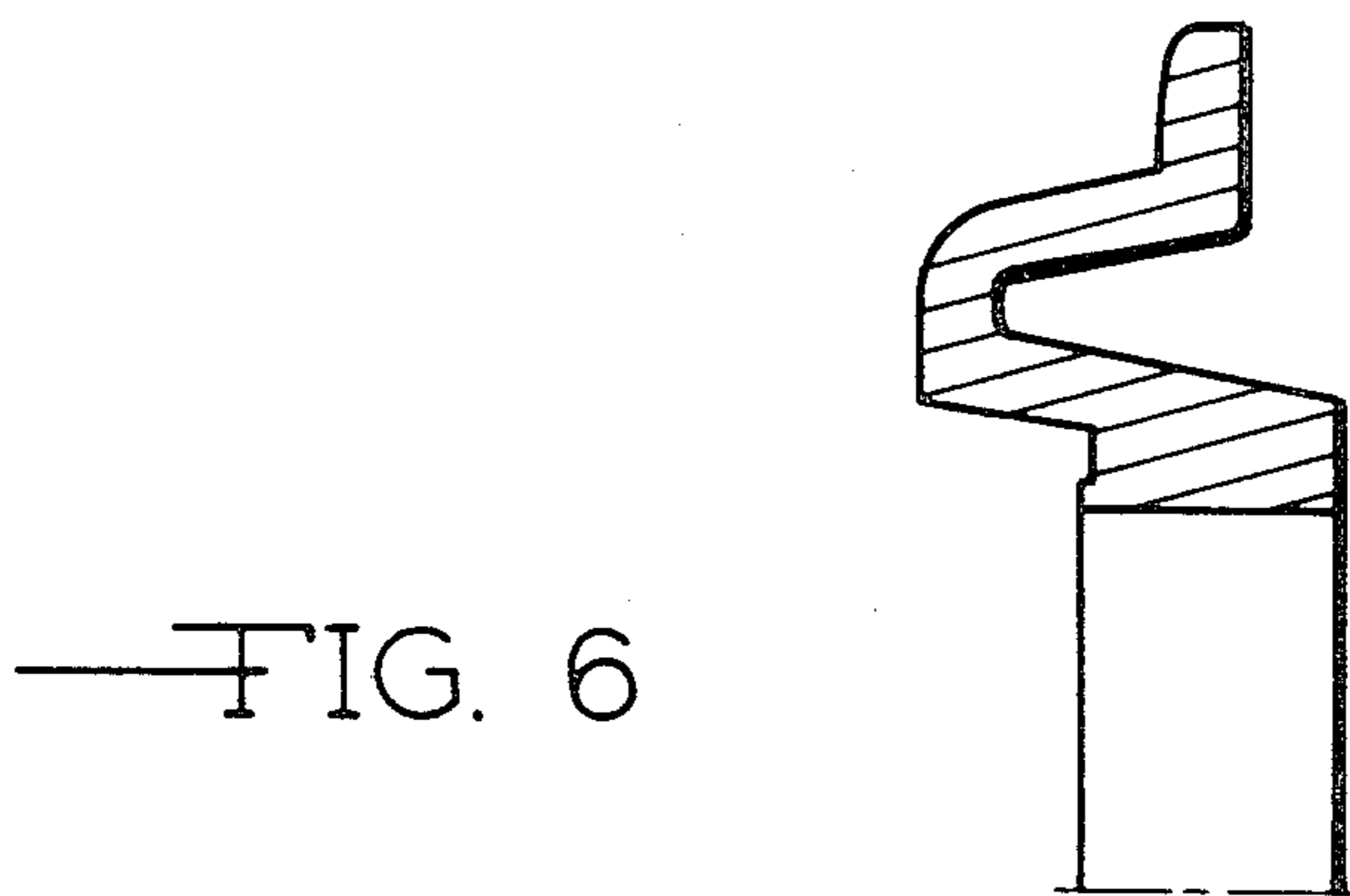
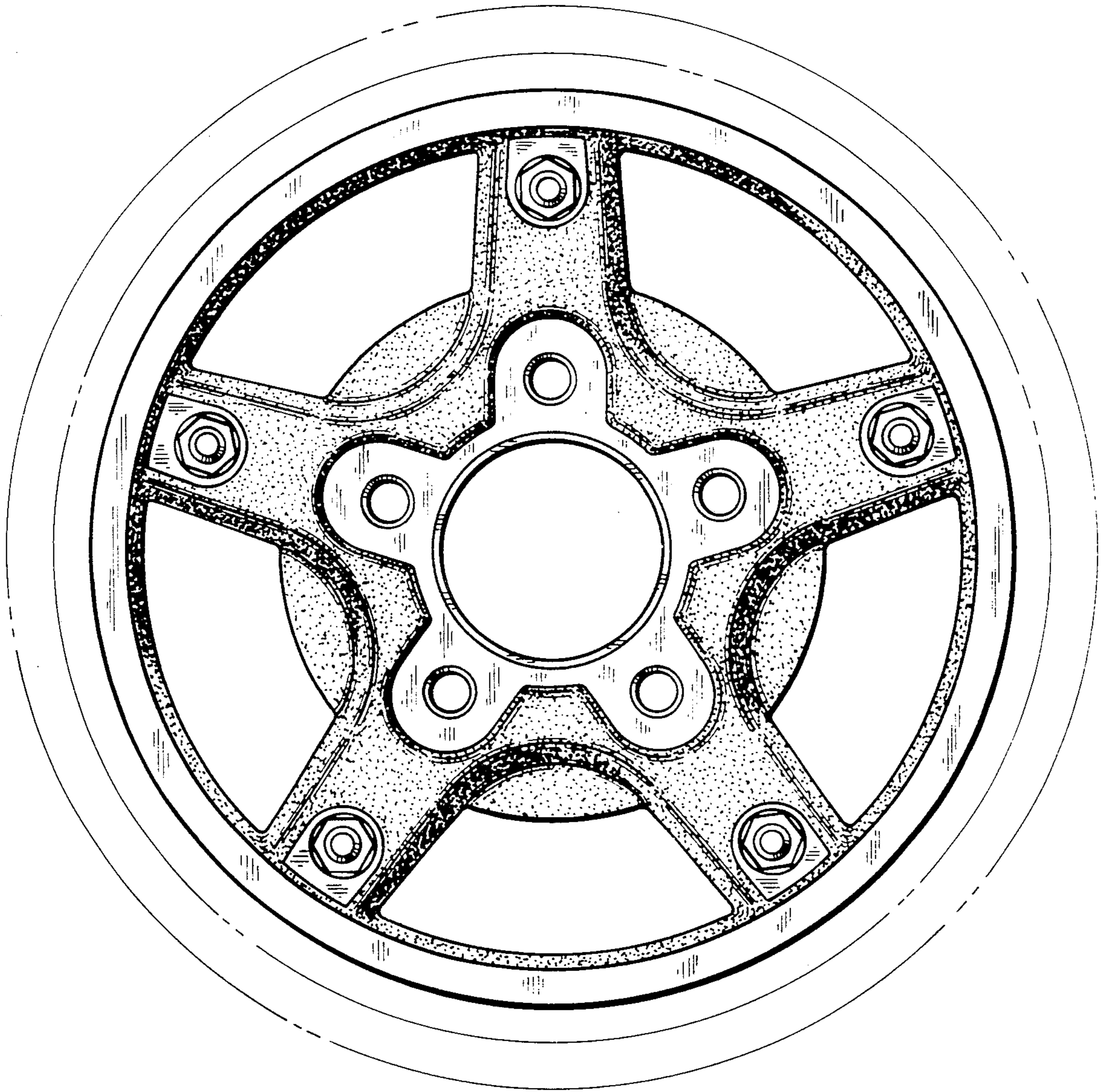

FIG. 6



—FIG. 7