

[54] RAIL ANCHOR

3,762,640 10/1973 Cantwell 238/327 R
4,210,281 7/1980 Fee 238/315

[75] Inventor: Graham M. Fee, Geneva, Ohio

Primary Examiner—B. J. Bullock

[73] Assignee: True Temper Railway Appliances, Inc., Chicago, Ill.

Attorney, Agent, or Firm—John K. Williamson; John L. LaPierre; James C. Valentine

[**] Term: 14 Years

[57] CLAIM

[21] Appl. No.: 439,105

The ornamental design for a rail anchor, as shown and described.

[22] Filed: Nov. 3, 1982

DESCRIPTION

[52] U.S. Cl. D8/382

FIG. 1 is an isometric view of a rail anchor showing my new design;

[58] Field of Search D8/382, 394; 238/315, 238/327 R, 349

FIG. 2 is a front elevational view thereof;

FIG. 3 is a top plan view thereof;

FIG. 4 is a bottom plan view thereof;

FIG. 5 is a side elevational view taken from the left of FIG. 1;

FIG. 6 is a side elevational view taken from the right of FIG. 1.

[56] References Cited

U.S. PATENT DOCUMENTS

2,251,685	8/1941	Moore et al.	238/315
3,102,690	9/1963	Fee	238/327 R
3,322,346	5/1967	Chapman	238/315

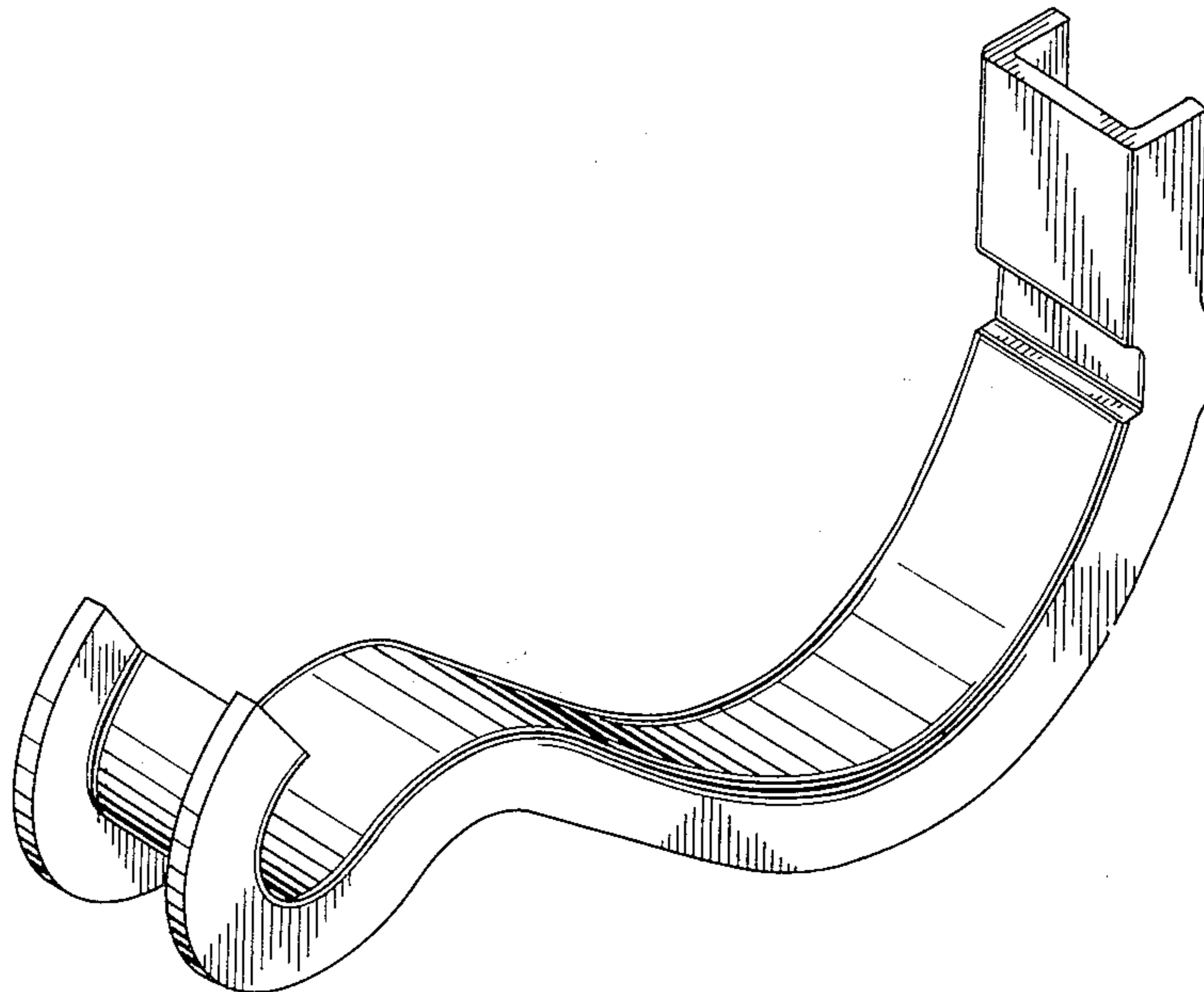

FIG. 1

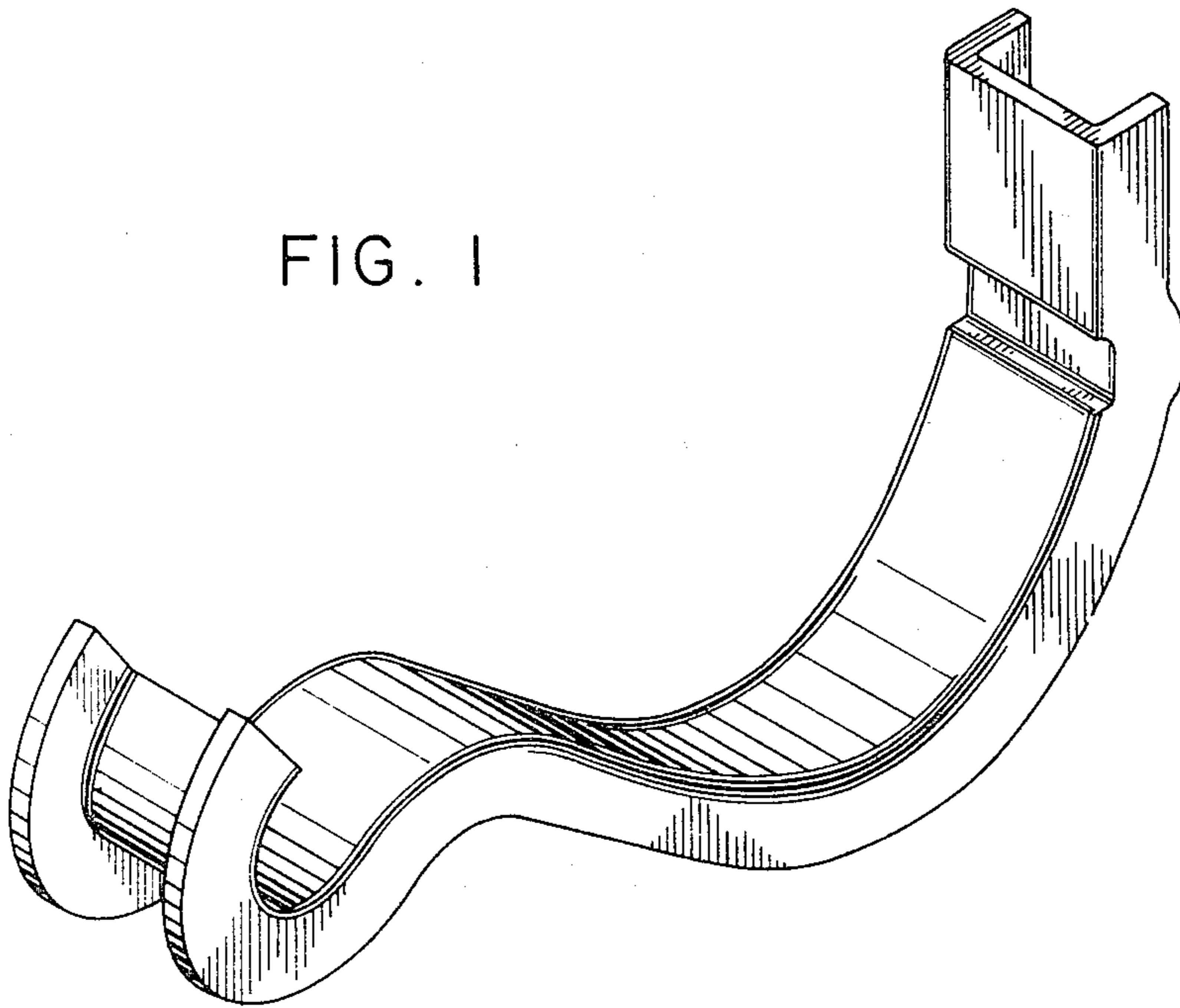

FIG. 2

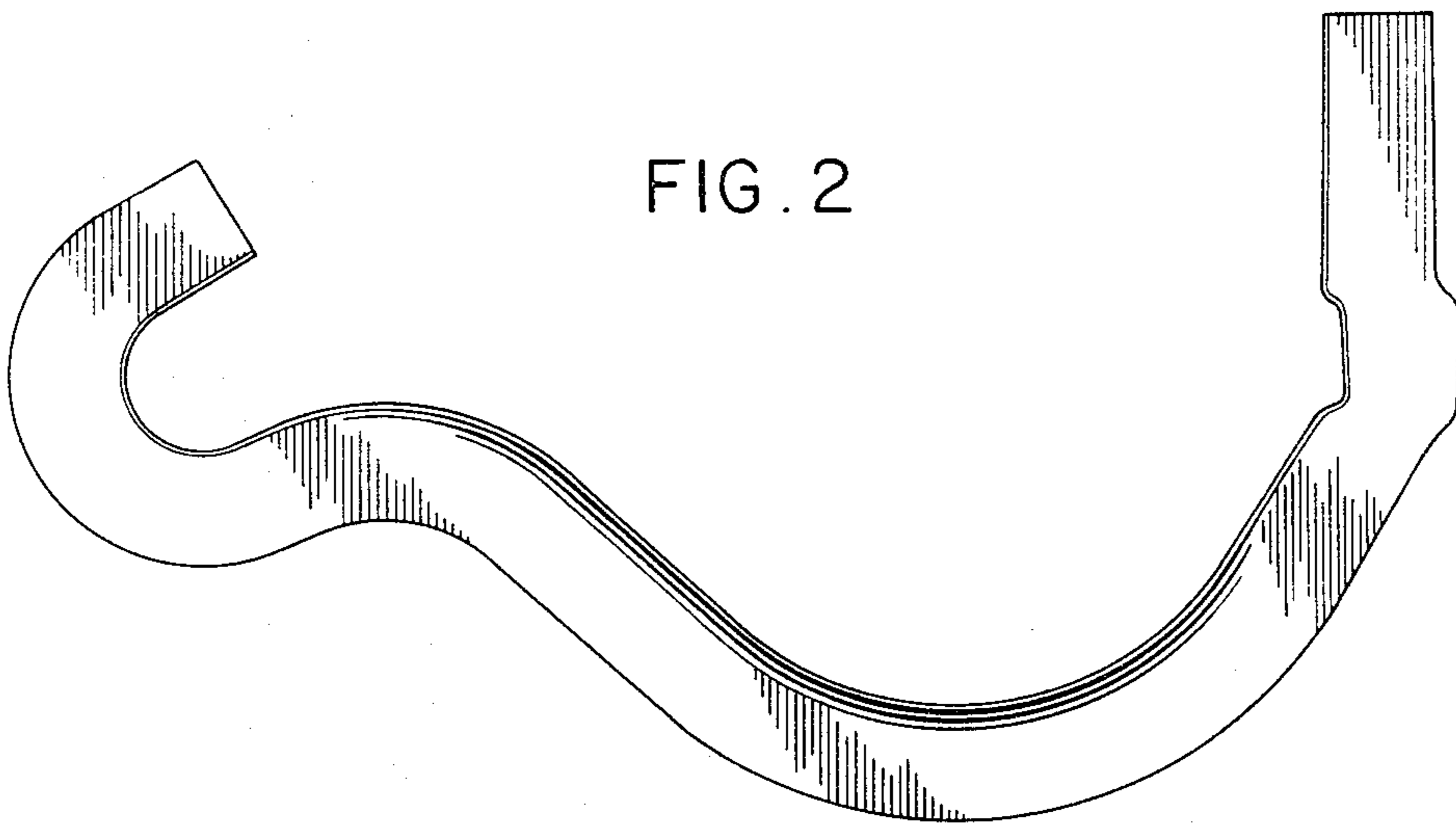

FIG. 3

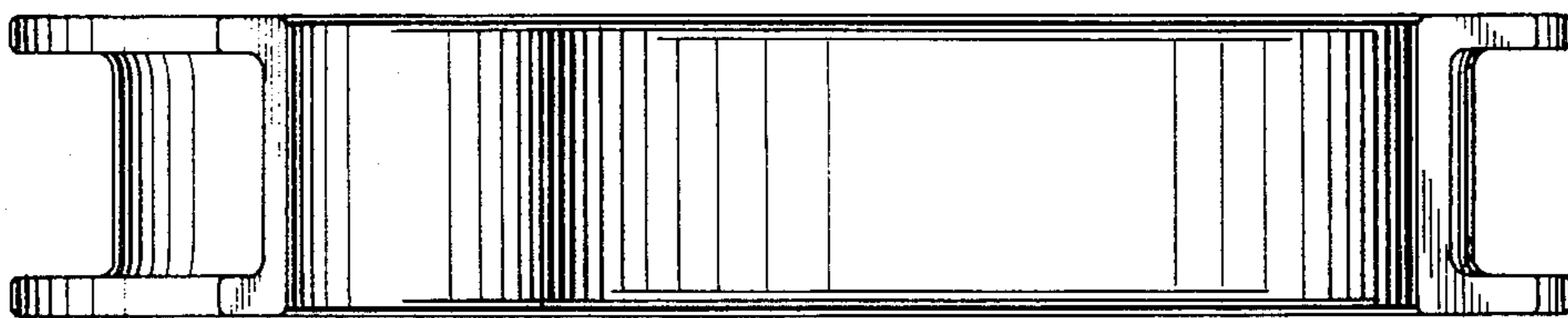

FIG. 4

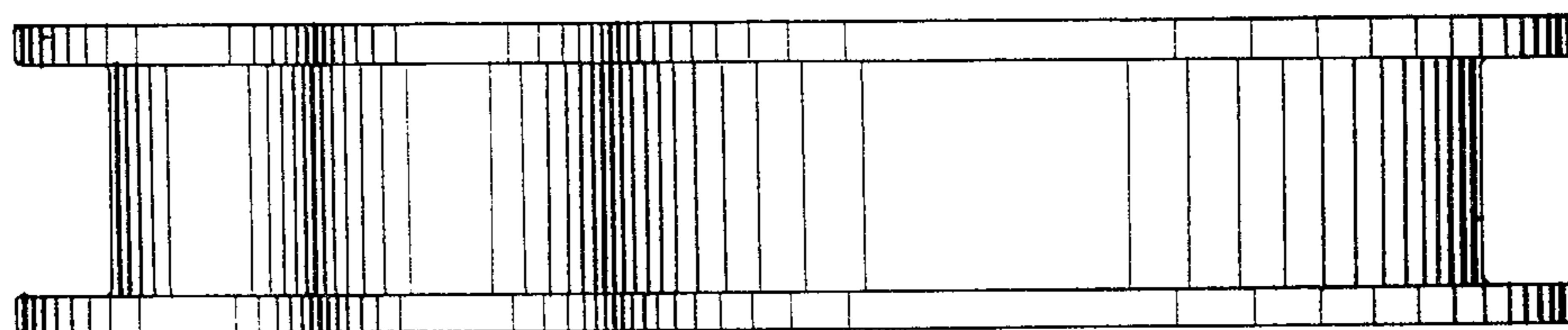

FIG. 5

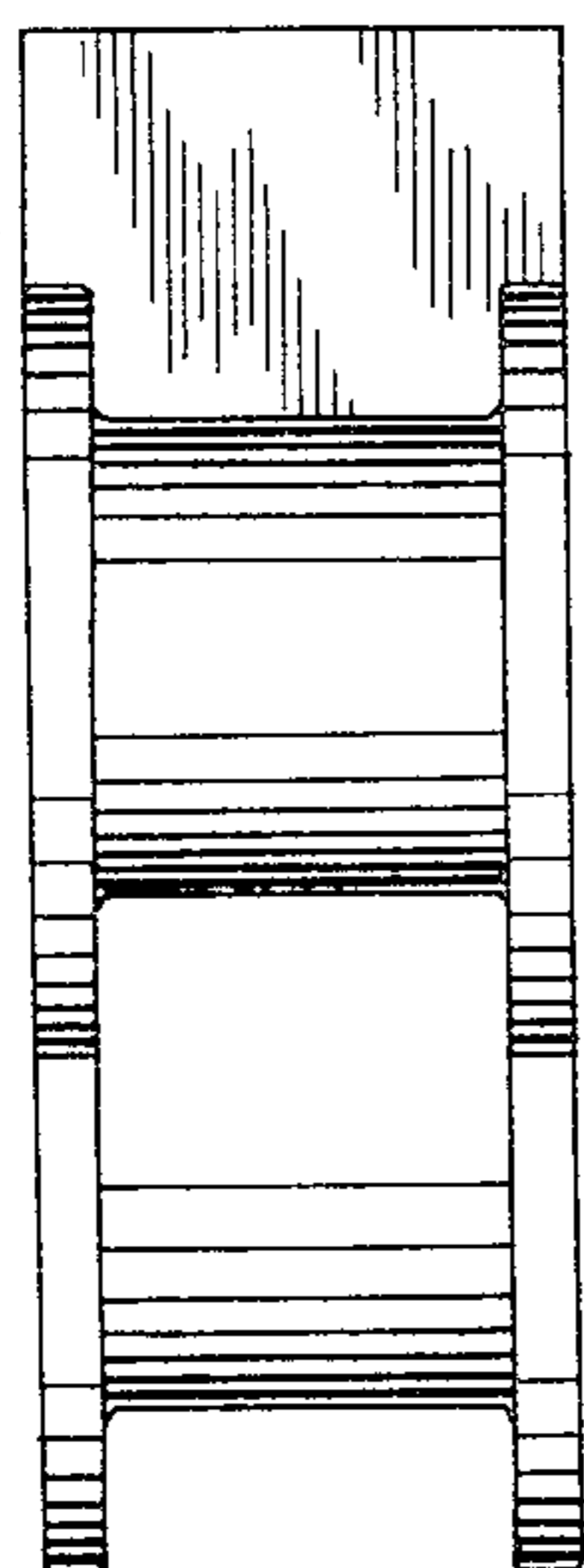

FIG. 6

