

[54] VEHICLE TIRE

[75] Inventors: Hideaki Nishio, Saitama; Hiroshi Kojima, Tokyo; Akira Inoue, Tokyo; Yuji Sakamaki, Tokyo, all of Japan

[73] Assignee: Bridgestone Tire Company Limited, Tokyo, Japan

[\*\*] Term: 14 Years

[21] Appl. No.: 372,262

[22] Filed: Apr. 26, 1982

[30] Foreign Application Priority Data

Oct. 27, 1981 [JP] Japan ..... 56-47511  
[52] U.S. Cl. .... D12/147  
[58] Field of Search ..... D12/141-143, D12/146-148; 152/209 R, 209 NT, 209 D

[56] References Cited

PUBLICATIONS

1981 Tread Design Guide, p. 40, General Jet Radial Tire, second tire in from bottom right side of page.

Modern Tire Dealer, Mid. Sep. 1981, p. 78, Tigar TG 505 Tire, center left side of page.

1981 Tread Design Guide, p. 68, Road King Widetrack Radial Outline-70 Tire, second row down right side of page.

Road & Track, 4/76, p. 80, Continental TS 772 Tire, top left side of page.

Primary Examiner—James M. Gandy  
Attorney, Agent, or Firm—Sughrue, Mion, Zinn, Macpeak & Seas

[57] CLAIM

The ornamental design for a vehicle tire, as shown and described.

DESCRIPTION

FIG. 1 is a perspective view of a vehicle tire showing our new design, it being understood that the tread pattern is repeated throughout the circumference of the tire;

FIG. 2 is an end view thereof;

FIG. 3 is a side elevational view thereof, the opposite side being a mirror image thereof; and

FIG. 4 is a cross-sectional view thereof taken about line IV—IV of FIG. 2.

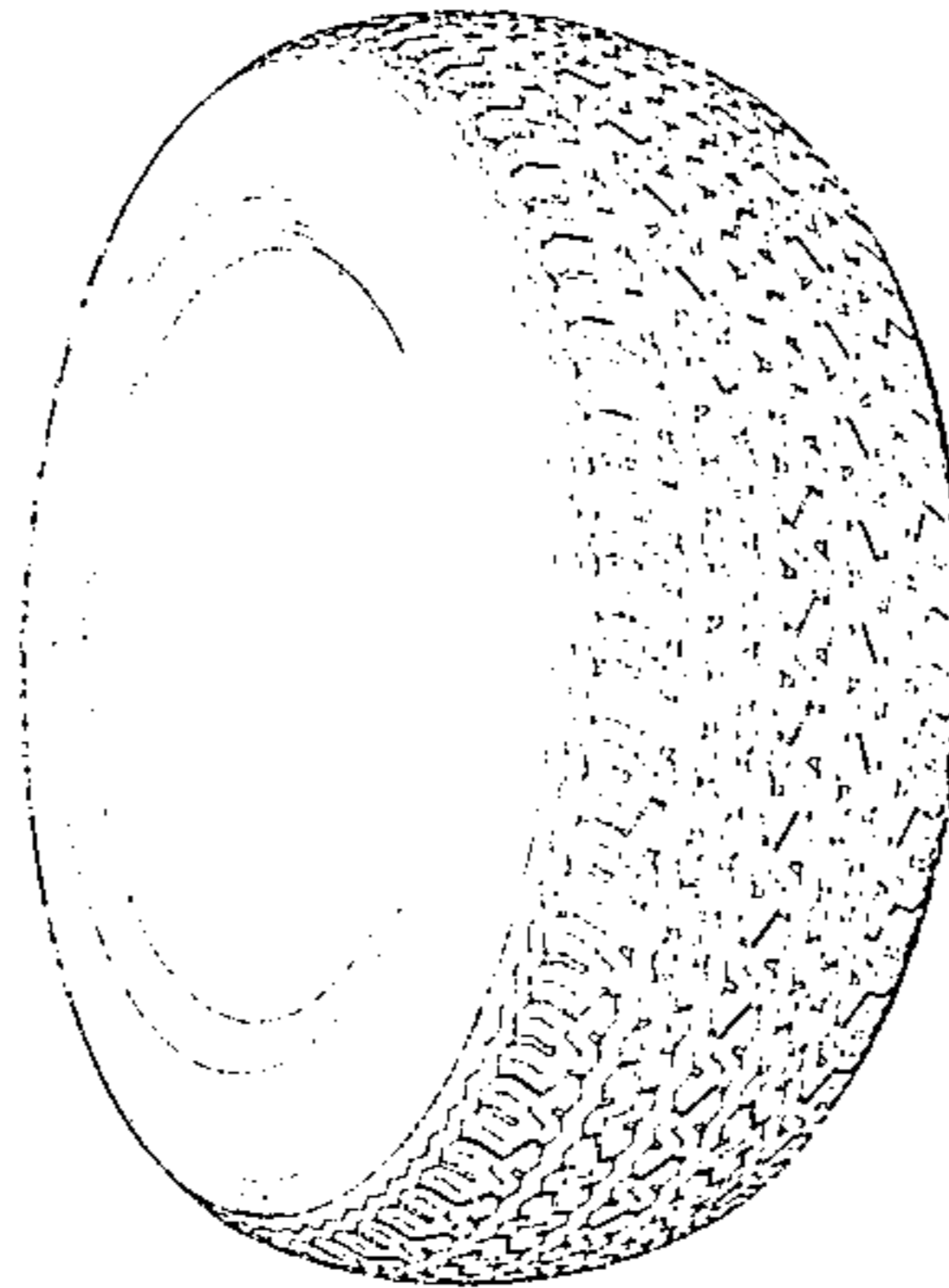

FIG. 2

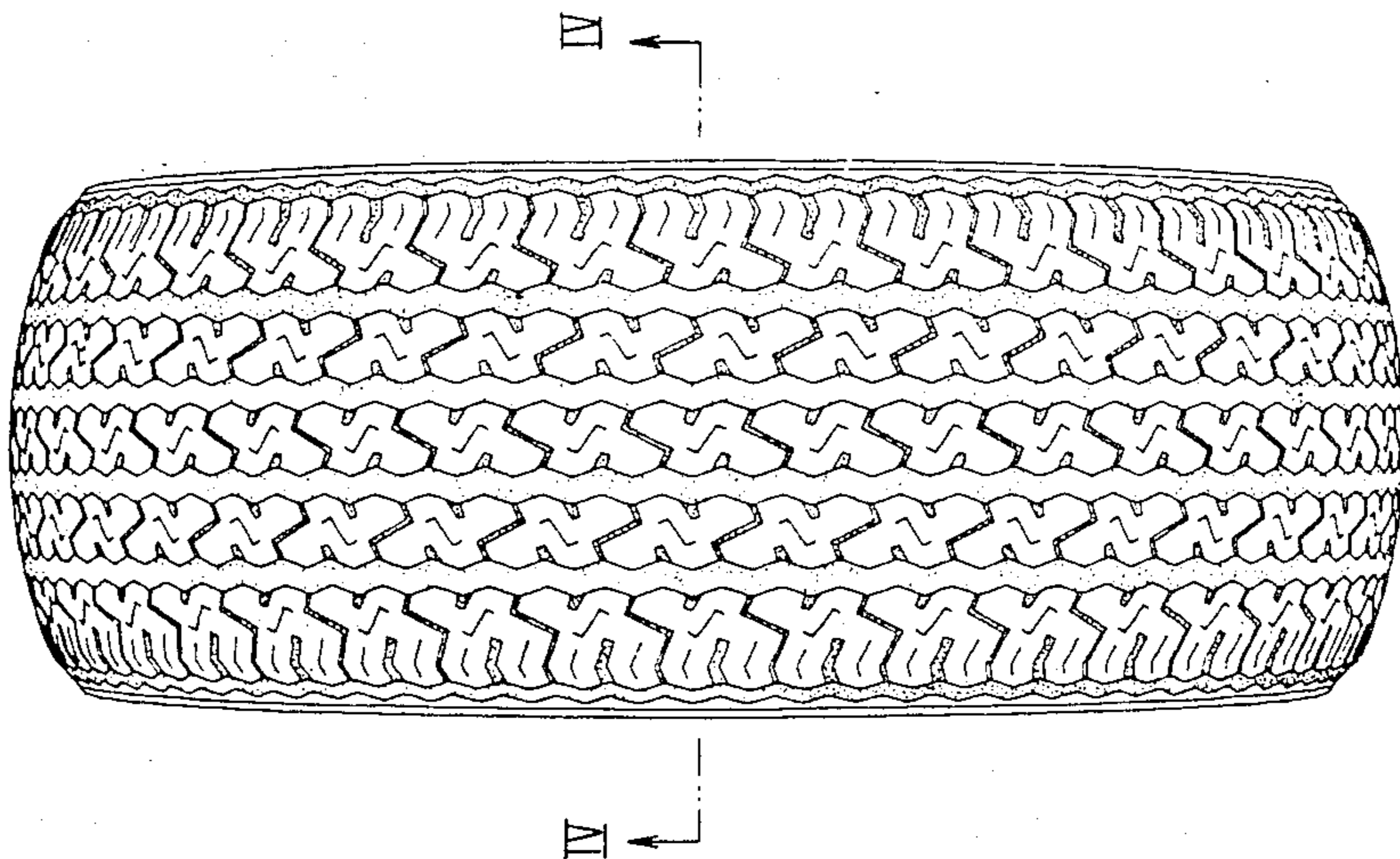
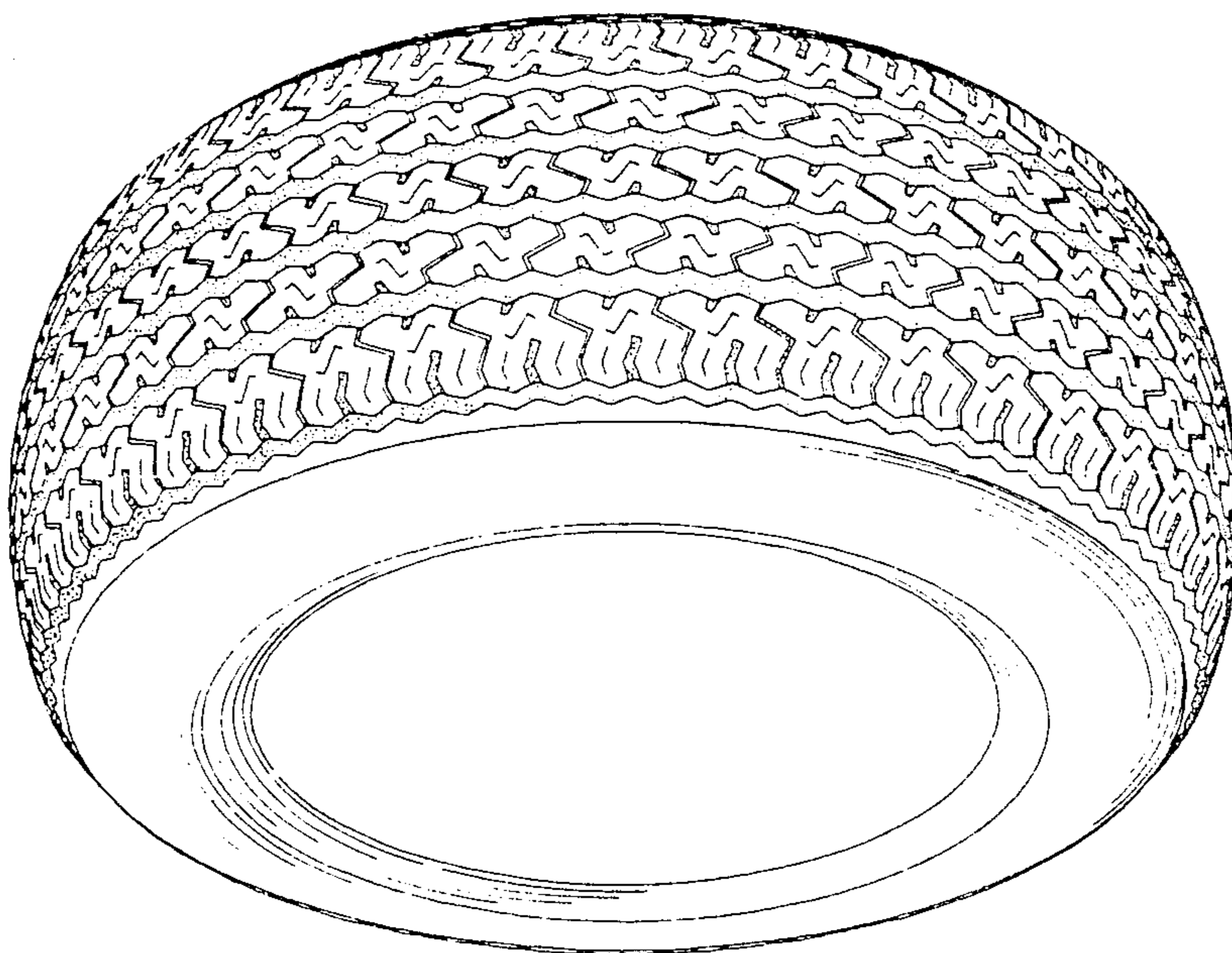

FIG. 1



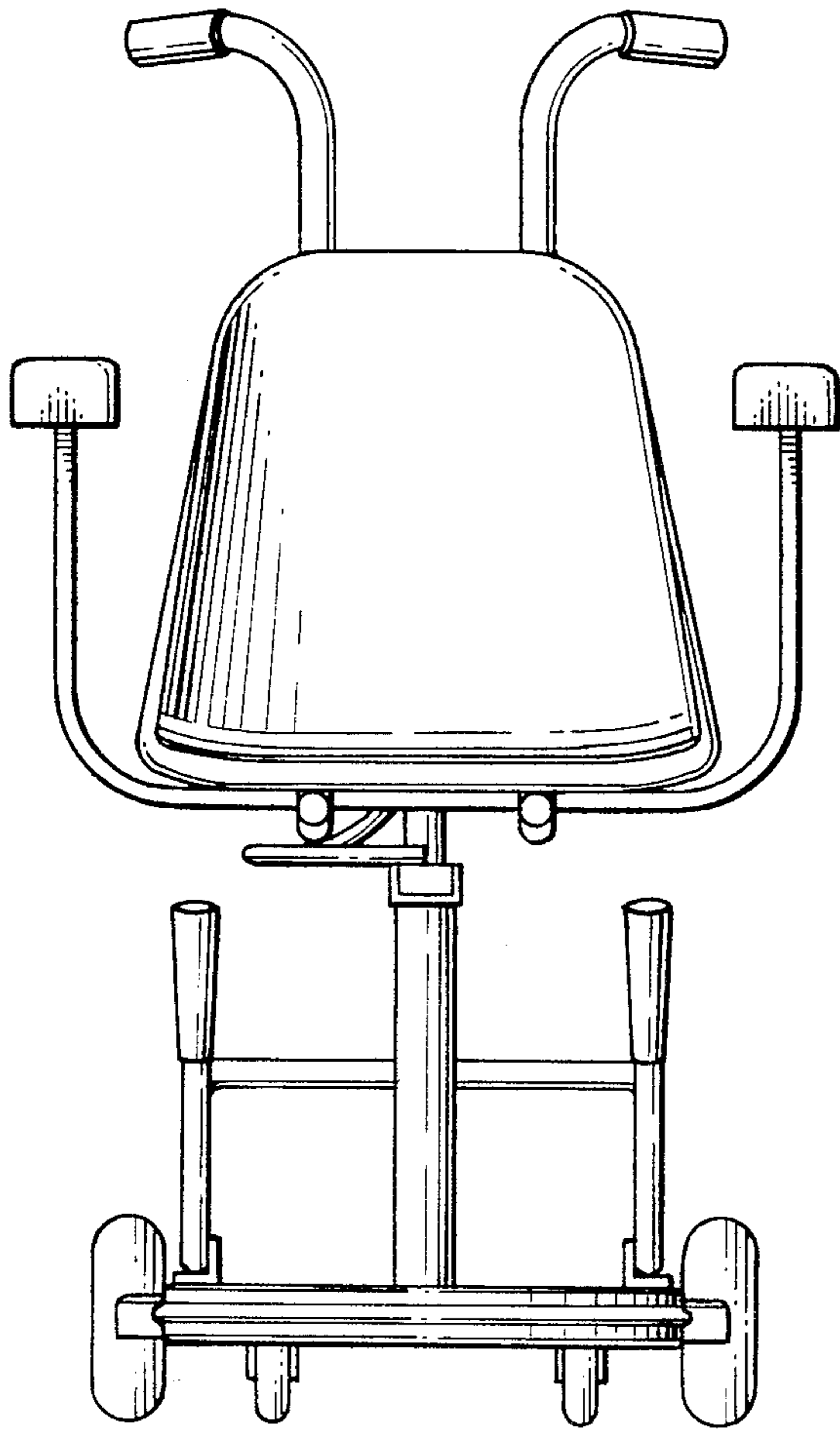

FIG.3

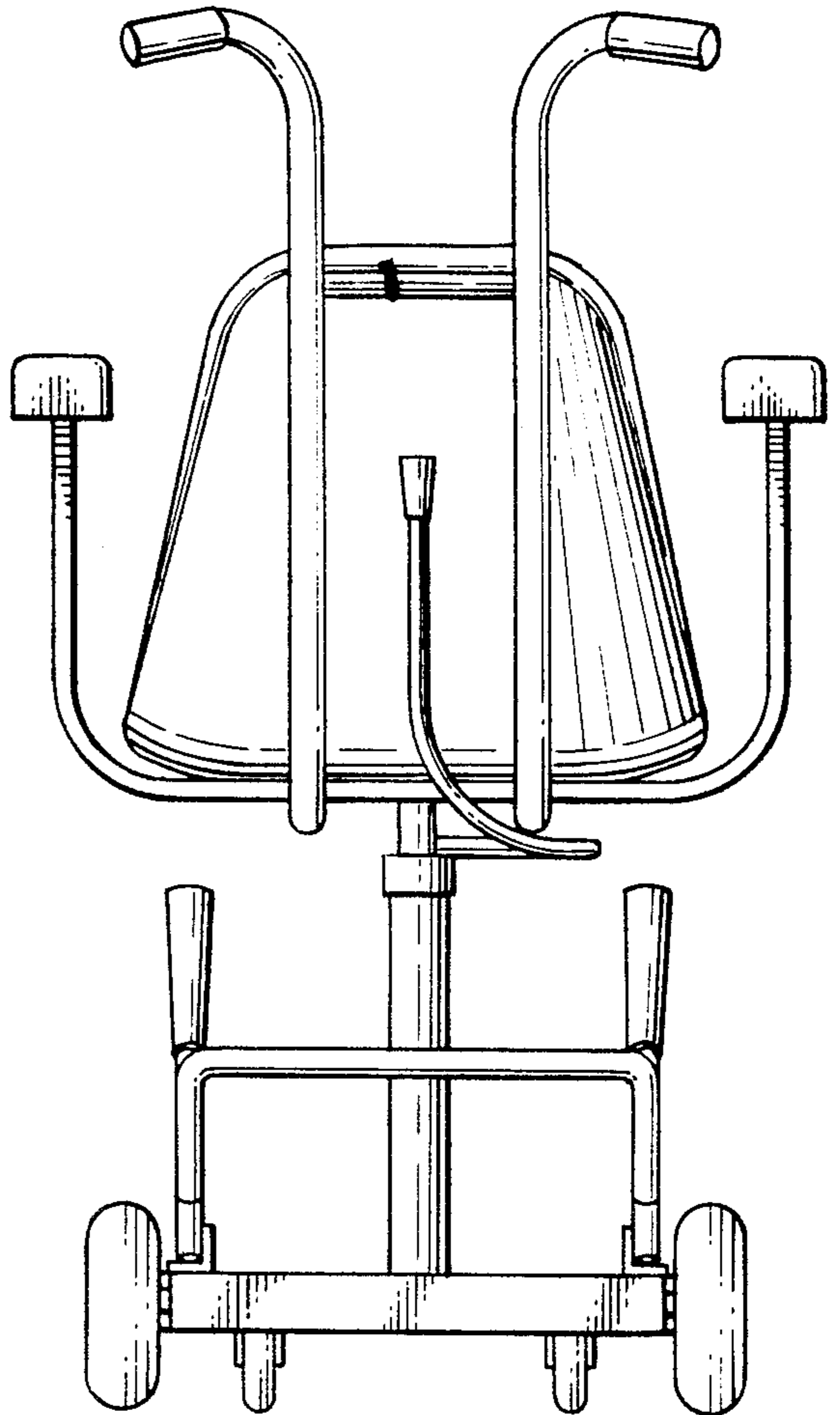

FIG.4

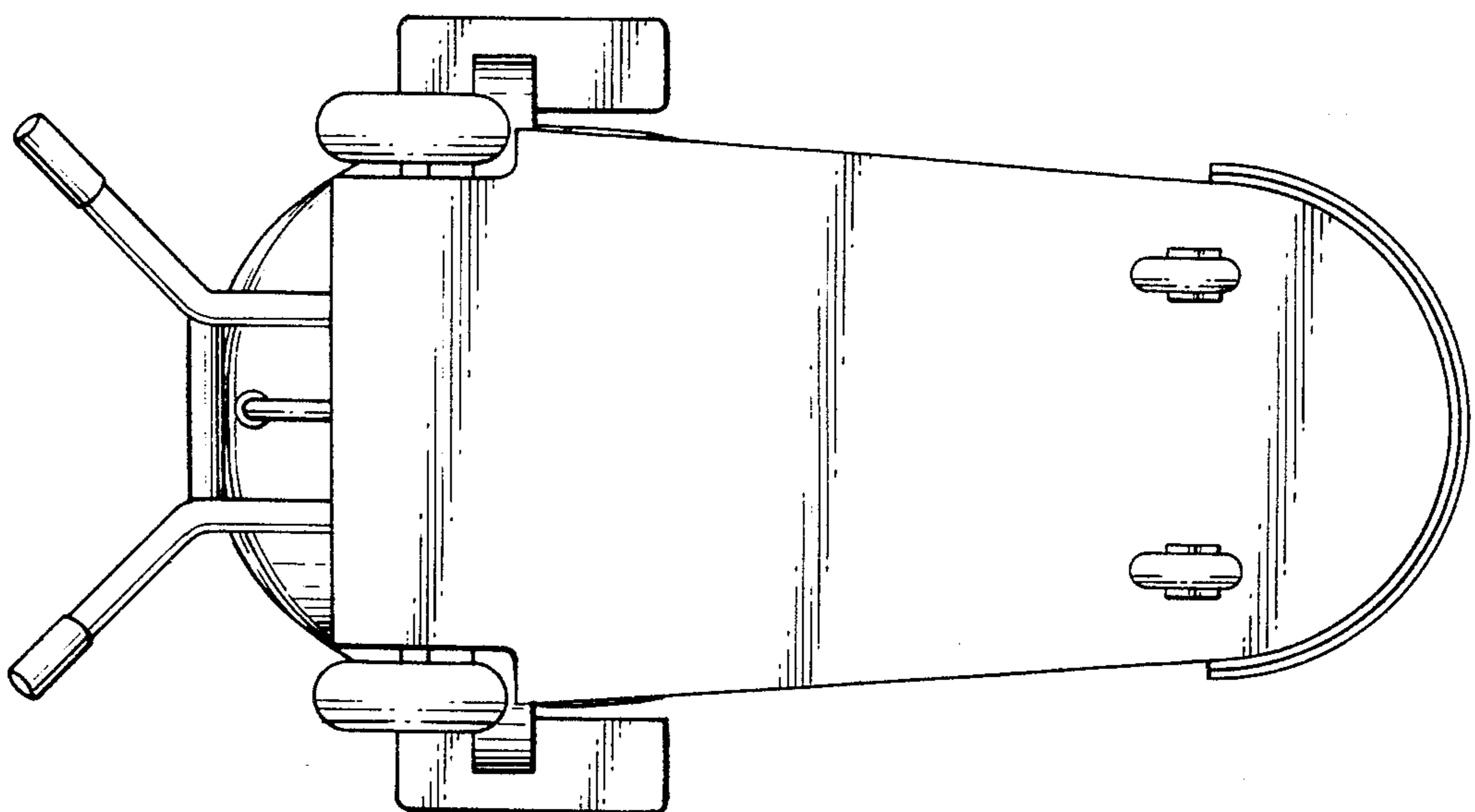

FIG.5



UNITED STATES PATENT AND TRADEMARK OFFICE  
**CERTIFICATE OF CORRECTION**

PATENT NO. : Des. 276,905

Page 1 of 2

DATED : Dec. 25, 1984

INVENTOR(S) : Hideaki Nishio et al

It is certified that error appears in the above-identified patent and that said Letters Patent is hereby corrected as shown below:

Sheet 2 of 2 of the drawings should be deleted to appear as per attached sheet 2 of 2 consisting of Figs. 3 and 4.

**Signed and Sealed this**

*Sixteenth Day of July 1985*

[SEAL]

*Attest:*

DONALD J. QUIGG

*Attesting Officer*

*Acting Commissioner of Patents and Trademarks*

FIG. 3

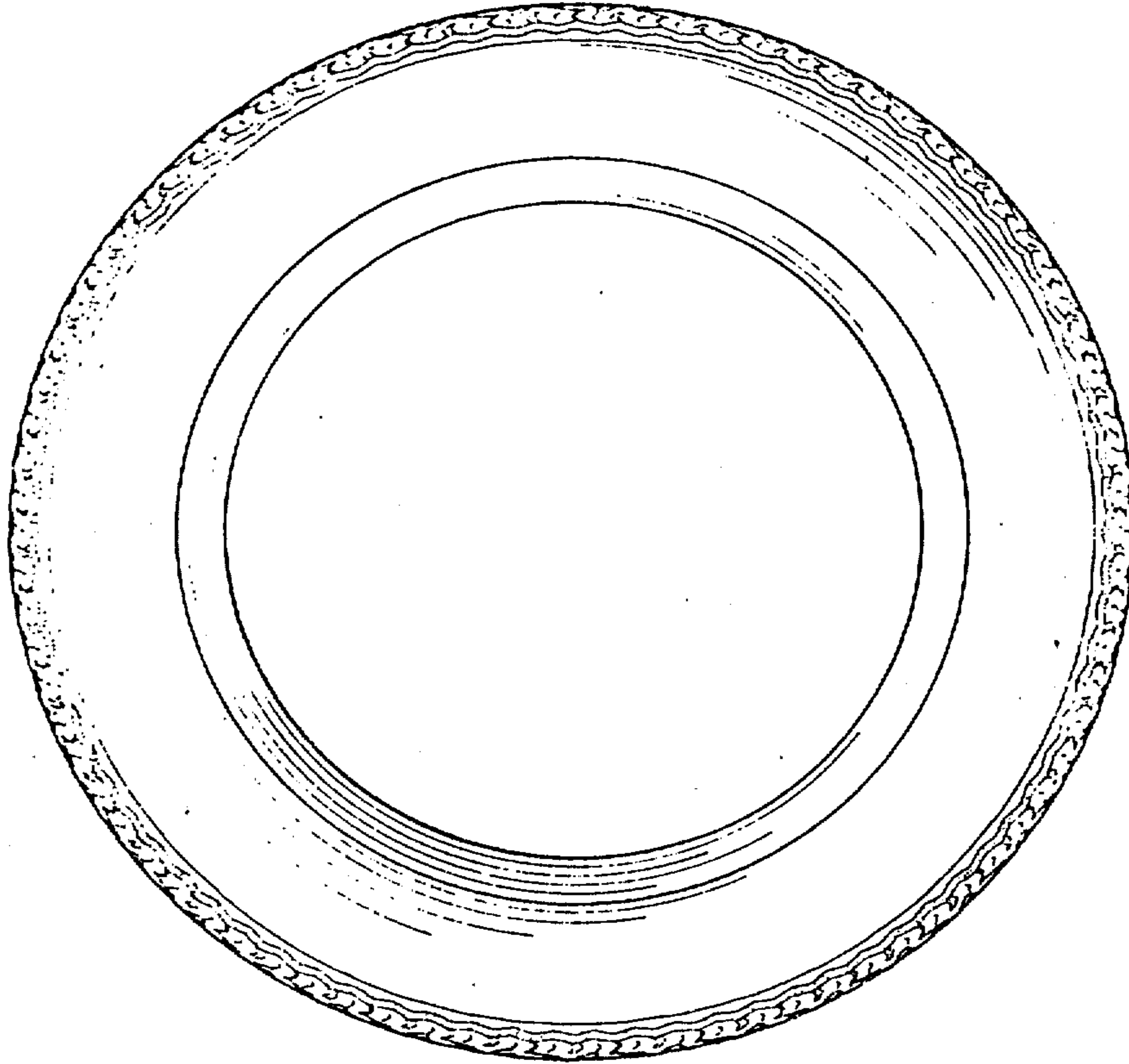

FIG. 4

