

United States Patent [19]

Strenger et al.

[11] Patent Number: **Des. 276,898**

[45] Date of Patent: **** Dec. 25, 1984**

[54] **PORTABLE GREENHOUSE**

[76] Inventors: **John R. Strenger**, 5 June Ter.; **Steven D. Blanchard**, 5 E. Scott St., both of Lake Forest, Ill. 60045

[**] Term: **14 Years**

[21] Appl. No.: **273,366**

[22] Filed: **Jun. 15, 1981**

Related U.S. Application Data

[63] Continuation-in-part of Ser. No. 65,353, Aug. 9, 1979, Pat. No. Des. 263,366.

[52] U.S. Cl. **D11/145; D8/1; D26/55**

[58] Field of Search **D11/143-156, D11/164; D8/1; D21/253; 47/17, 28, 29, 30; 362/253, 805; D26/55**

[56] **References Cited**

U.S. PATENT DOCUMENTS

1,392,178 9/1921 Kuebler 47/29

4,304,068 12/1981 Beder D11/145

FOREIGN PATENT DOCUMENTS

0845821 9/1939 France 47/28
0419000 11/1934 United Kingdom 47/29

OTHER PUBLICATIONS

Bloomington's "Living Quarters"; opposite p. 16; Plant Watcher P.

Primary Examiner—B. J. Bullock

Attorney, Agent, or Firm—Lee, Smith & Jager

[57] **CLAIM**

The ornamental design for a portable greenhouse, as shown and described.

DESCRIPTION

FIG. 1 is a front perspective view of a portable greenhouse showing our new design;

FIG. 2 is a front elevational view thereof;

FIG. 3 is a side elevational view thereof; and

FIG. 4 is a top plan view thereof.

The bottom of the portable greenhouse is flat and plain.

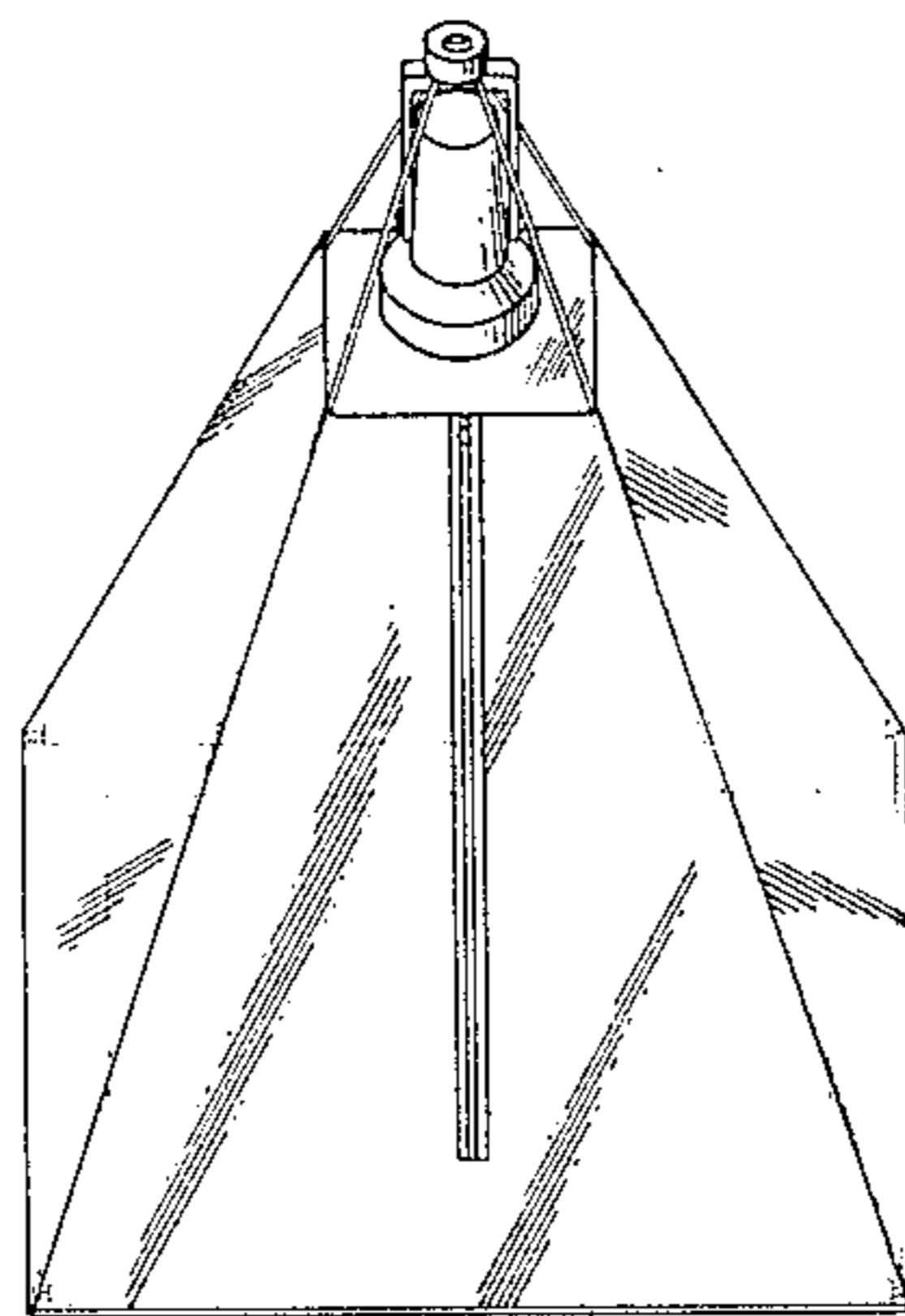

fig. 1.

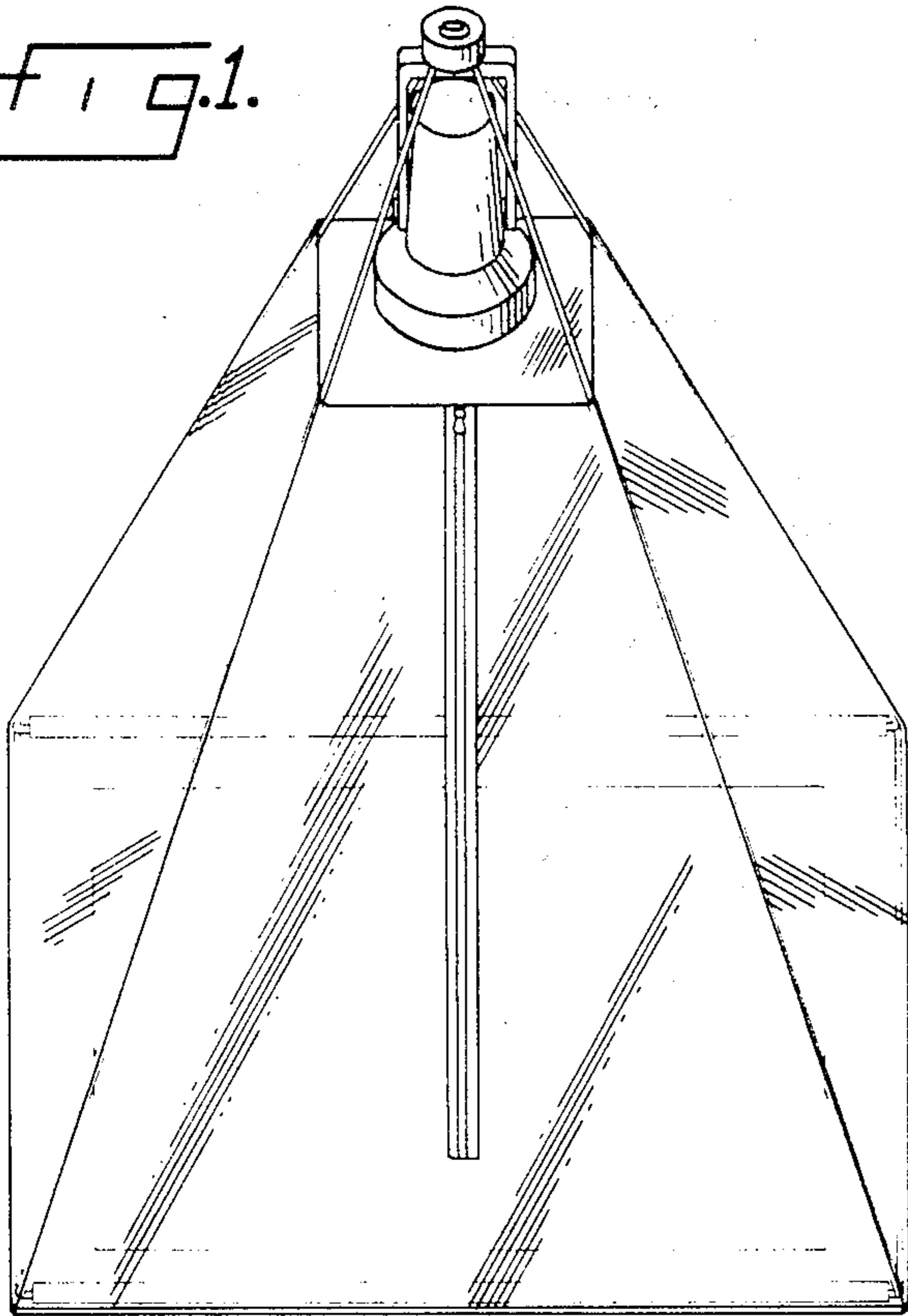

fig. 4.

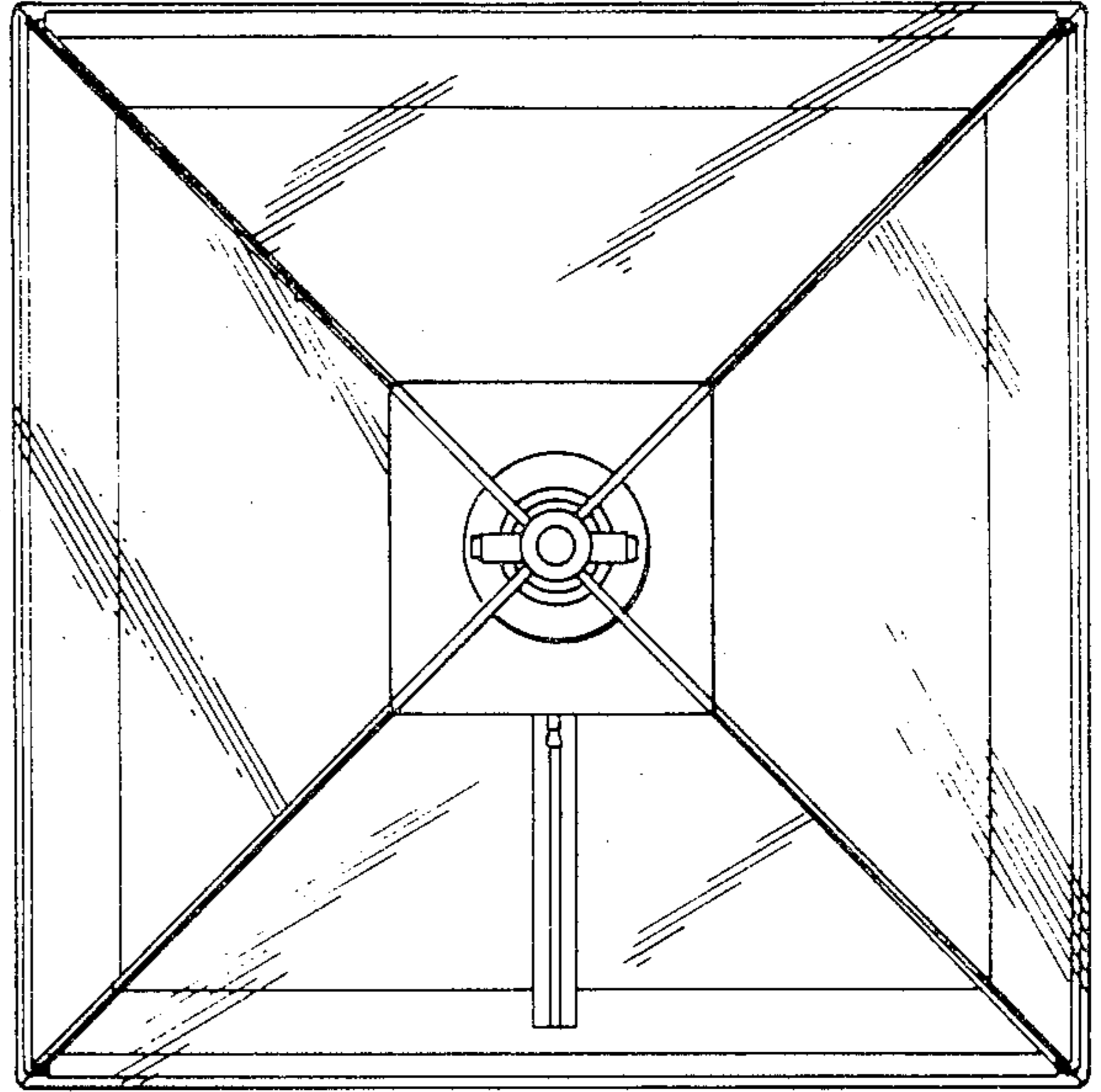

fig. 2.

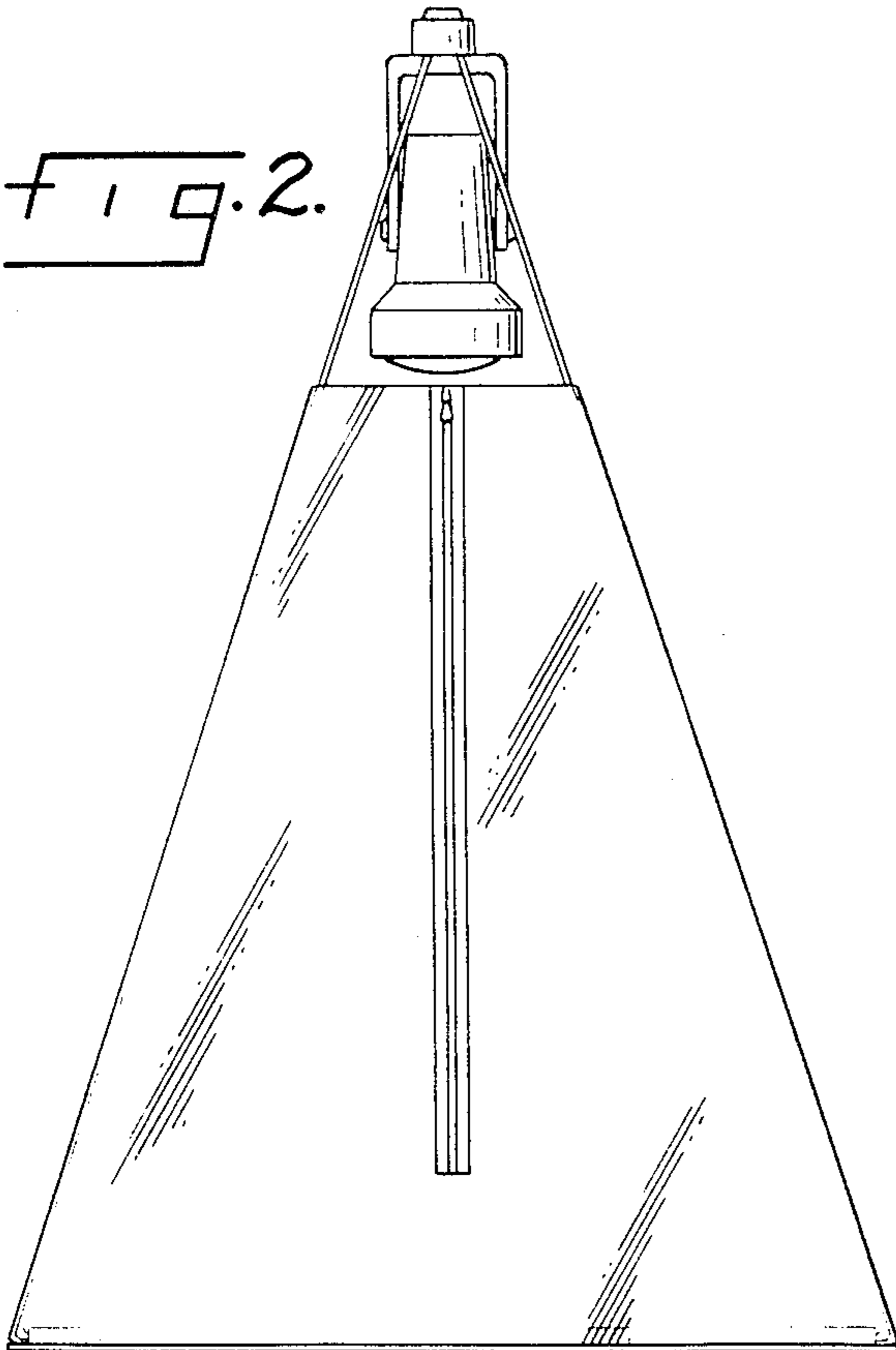

fig. 3.

