

[54] WHEEL FOR MOTORCYCLE
[75] Inventors: Tetuo Ogishima, Shiki; Aiko Hiratsuka, Fijimi, both of Japan

43001 4/1981 Japan 301/63 PW
550252 9/1981 Japan .
550313 9/1981 Japan .

[73] Assignee: Honda Giken Kogyo Kabushiki Kaisha, Tokyo, Japan

[**] Term: 14 Years

[21] Appl. No.: 357,651

[22] Filed: Mar. 12, 1982

[30] Foreign Application Priority Data

Sep. 19, 1981 [JP] Japan 56/41630

[52] U.S. Cl. D12/211

[58] Field of Search D12/205, 209, 211;
301/63 R, 63 PW, 64 R, 64 SD, 65, 66

[56] References Cited

U.S. PATENT DOCUMENTS

D. 271,865 12/1983 Morioka D12/110

FOREIGN PATENT DOCUMENTS

550146 2/1956 Japan .
550317 2/1956 Japan .

OTHER PUBLICATIONS

Autocar, 10/18/75, p. 38, Renault Wheel, center right side of page.

Primary Examiner—James M. Gandy
Attorney, Agent, or Firm—Armstrong, Nikaido, Marmelstein & Kubovcik

[57] CLAIM

The ornamental design for a wheel for motorcycle, as shown and described.

DESCRIPTION

FIG. 1 is a right side elevational view of a wheel for a motorcycle, showing our new design;
FIG. 2 is a left side elevational view thereof;
FIG. 3 is a top plan view thereof;
FIG. 4 is a front elevational view thereof;
FIG. 5 is a sectional view taken along the line V—V in FIG. 1; and
FIG. 6 is an enlarged sectional view taken along the line VI—VI in FIG. 1.

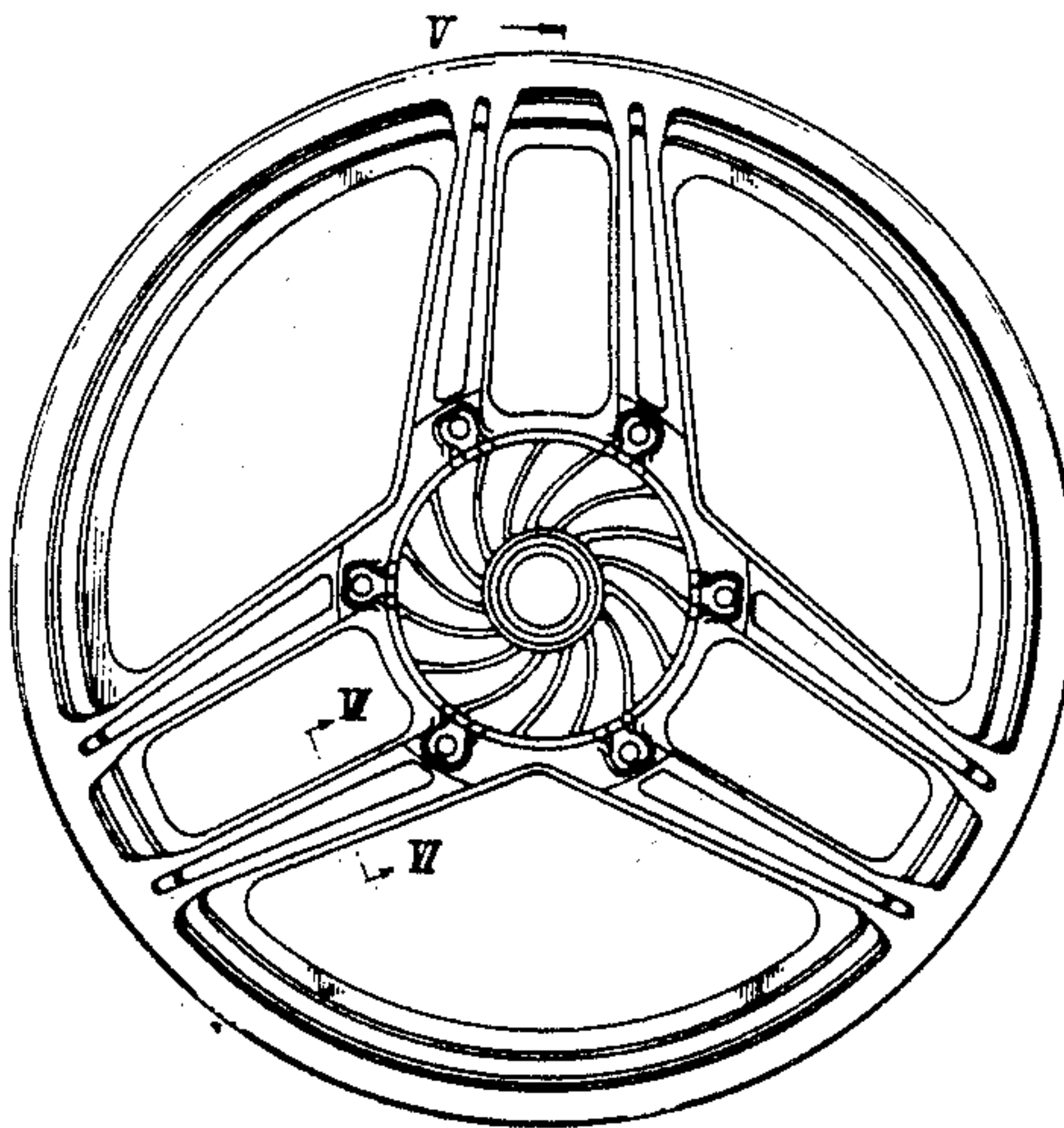

FIG. 1

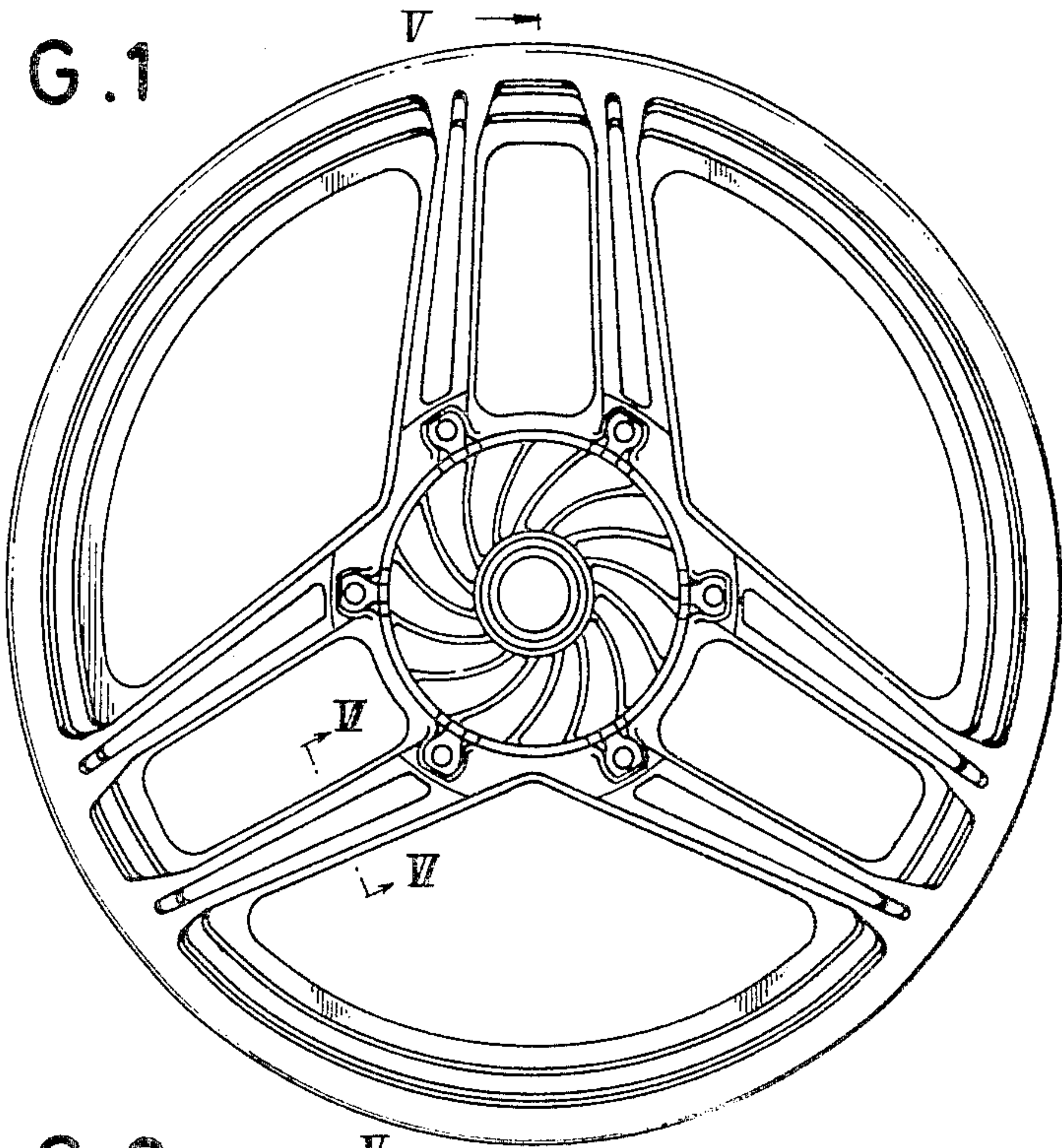

FIG. 2

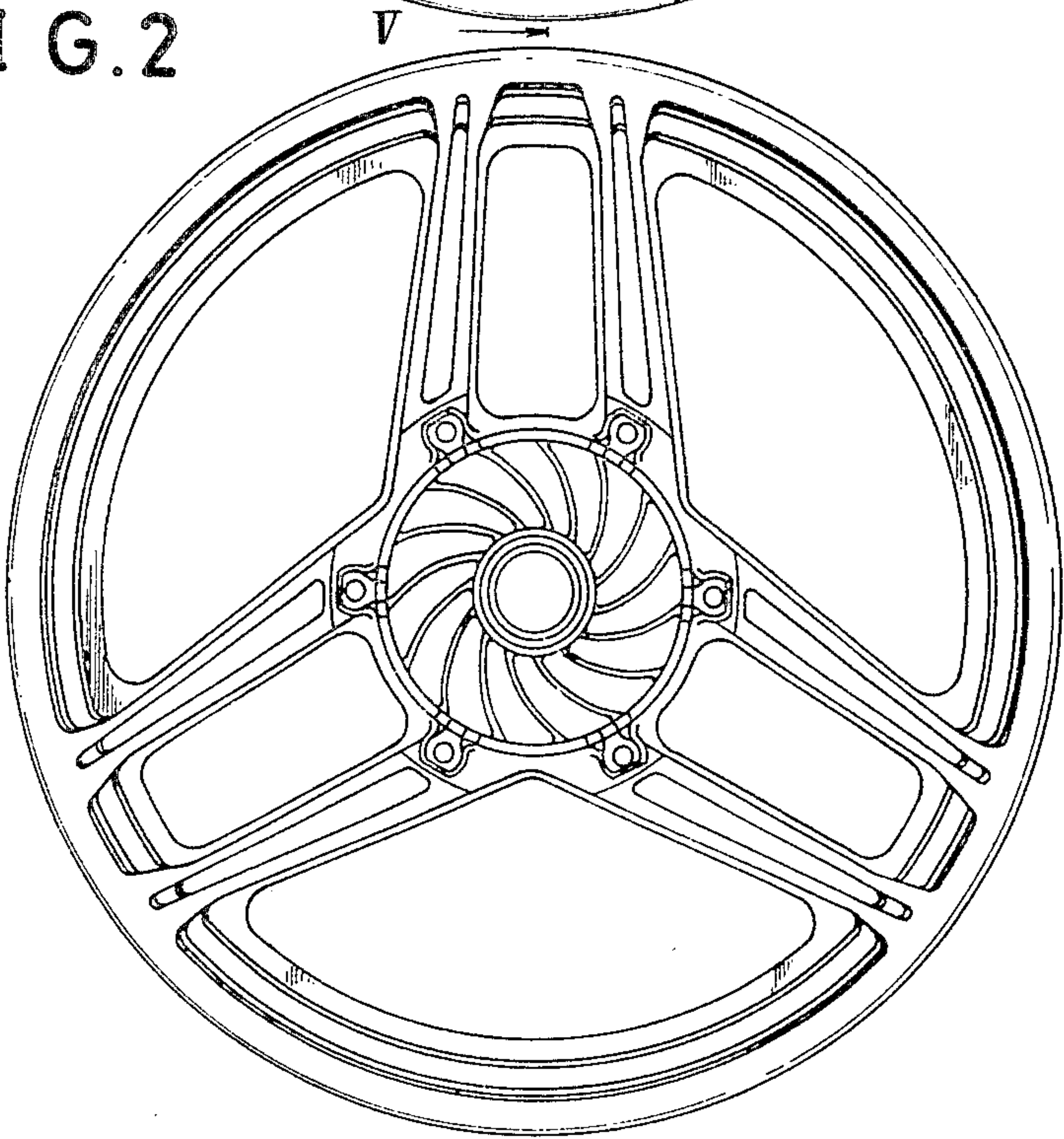

FIG. 3

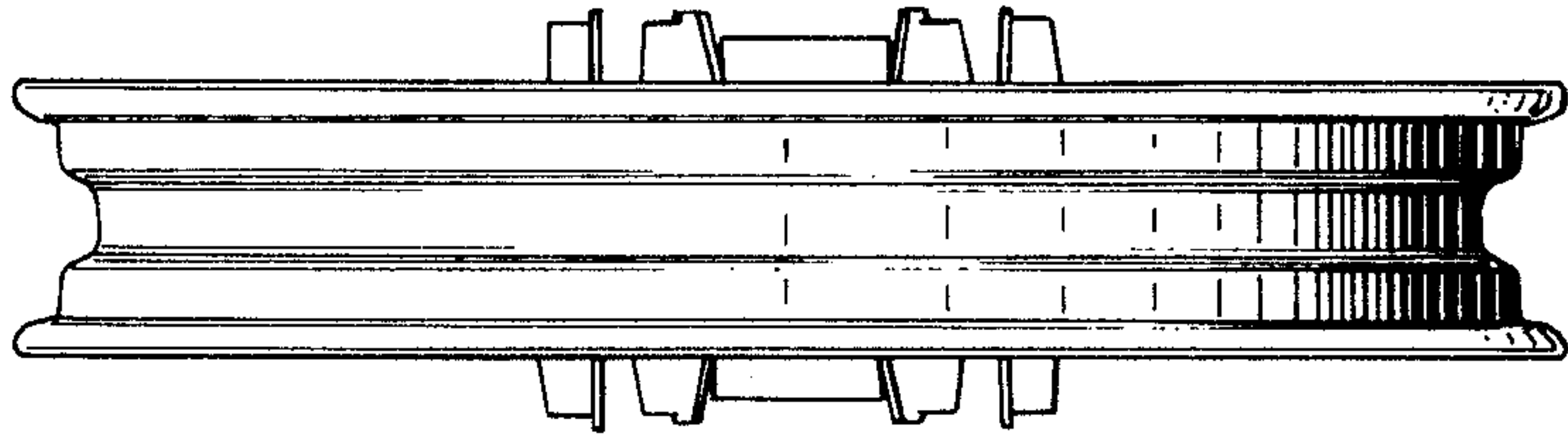

FIG. 4

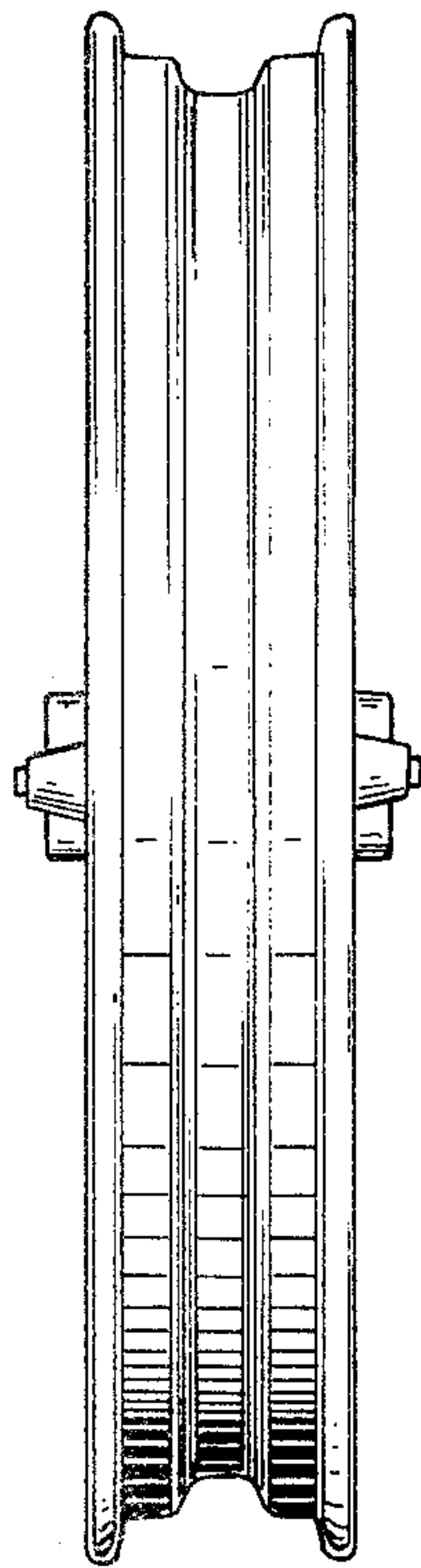

FIG. 5

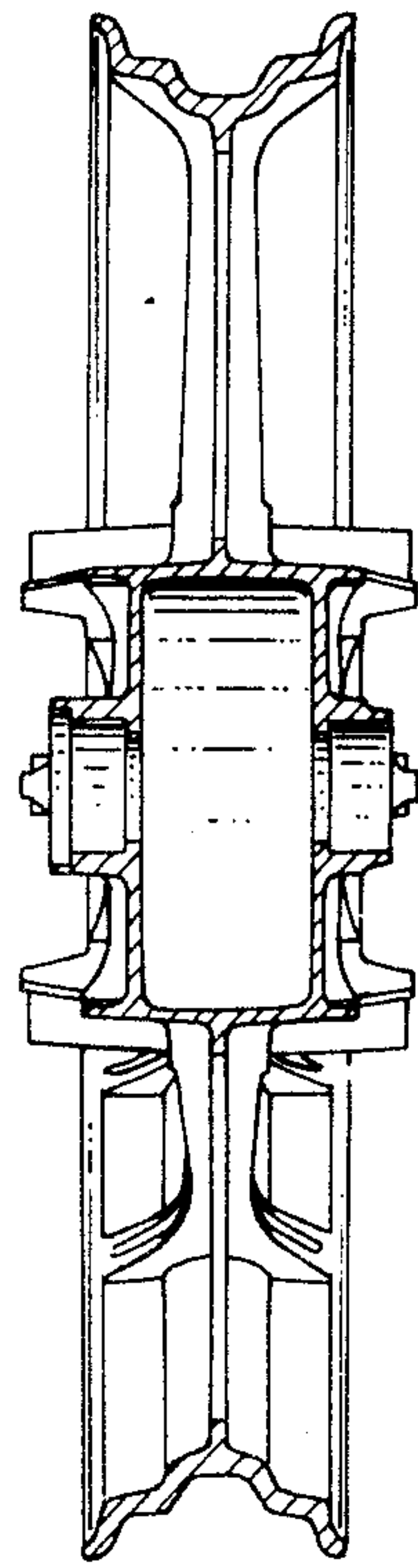
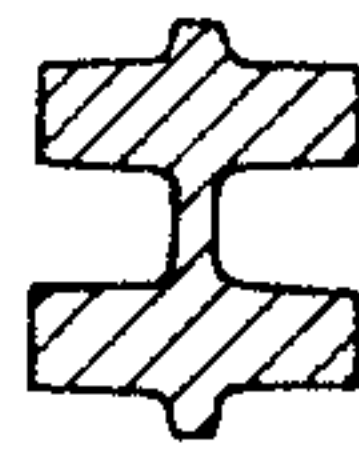

FIG. 6



UNITED STATES PATENT AND TRADEMARK OFFICE
CERTIFICATE OF CORRECTION

PATENT NO. : Des. 276,717

Page 1 of 2

DATED : December 11, 1984

INVENTOR(S) : TETUO OGISHIMA ET AL

It is certified that error appears in the above-identified patent and that said Letters Patent is hereby corrected as shown below:

Figure 4 should appear as shown on the attached sheet.

Signed and Sealed this

Twenty-fourth **Day of** *September 1985*

[SEAL]

Attest:

DONALD J. QUIGG

Attesting Officer

*Commissioner of Patents and
Trademarks—Designate*

FIG. 4

