

[54] **PASSENGER CAR**

[75] **Inventors: Masahito Nakano; Yusuke Saitoh,**
both of Saitama, Japan

[73] **Assignee: Honda Giken Kogyo Kabushiki**
Kaisha, Tokyo, Japan

[**] **Term: 14 Years**

[21] **Appl. No.: 351,420**

[22] **Filed: Feb. 25, 1982**

[30] **Foreign Application Priority Data**

Aug. 25, 1981 [JP] Japan 56/37356

[52] **U.S. Cl. D12/92**

[58] **Field of Search D12/91, 92; D21/136;**
296/185

[56] **References Cited**

U.S. PATENT DOCUMENTS

D. 257,835 1/1981 Nakano D12/92

OTHER PUBLICATIONS

Motor Trend, 10/81, p. 50, Volkswagen Jetta, top of page.

Motor Trend, 11/81, p. 28, 1982 Honda Accord.

Motor Trend, 5/81, p. 23, Oldsmobile Cutlass, top of page.

Motor Trend, 5/81, p. 99, Audi 4000 5+5.

Primary Examiner—James M. Gandy

Attorney, Agent, or Firm—Lyon & Lyon

[57] **CLAIM**

The ornamental design for a passenger car, substantially as shown.

DESCRIPTION

FIG. 1 is a top plan view of a passenger car embodying our new design.

FIG. 2 is a right side elevation view thereof.

FIG. 3 is a front elevation view thereof.

FIG. 4 is a rear elevation view thereof.

FIG. 5 is a left side elevation view thereof.

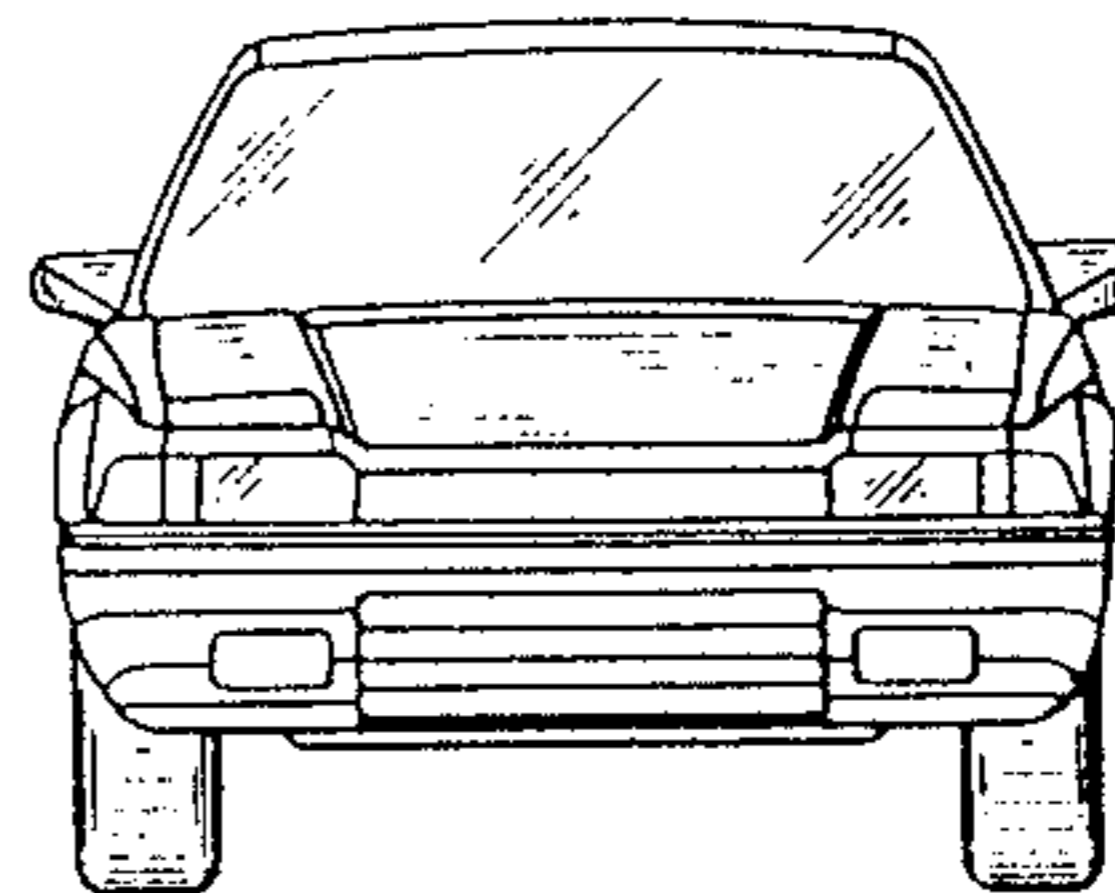
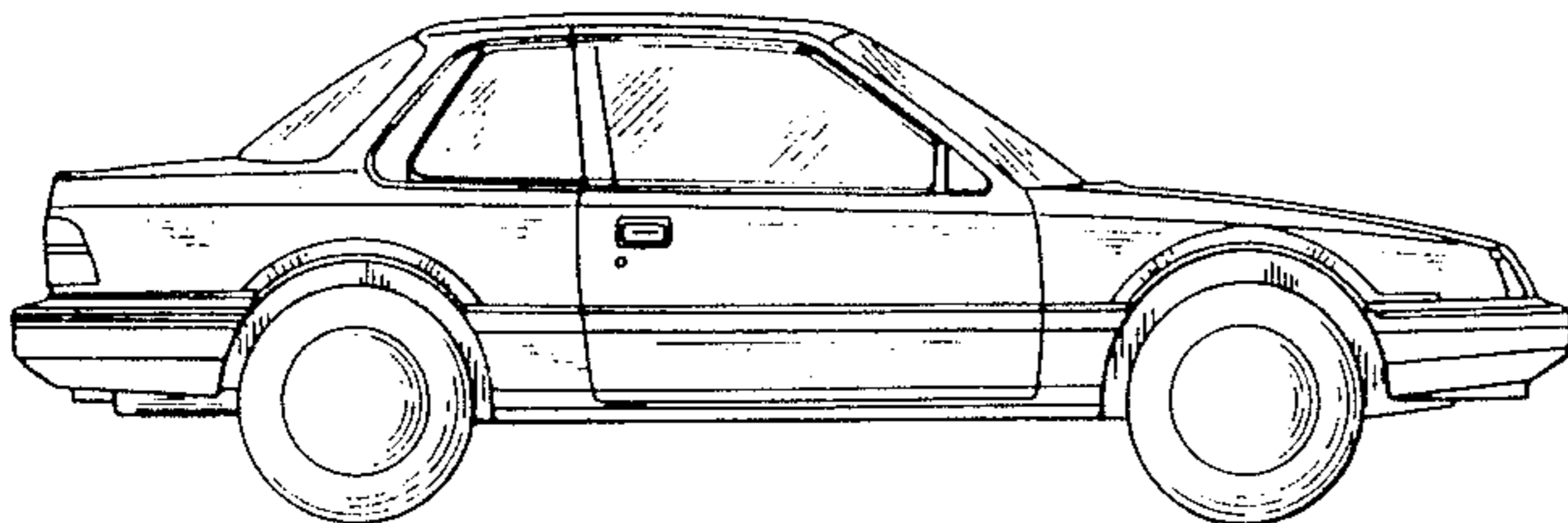

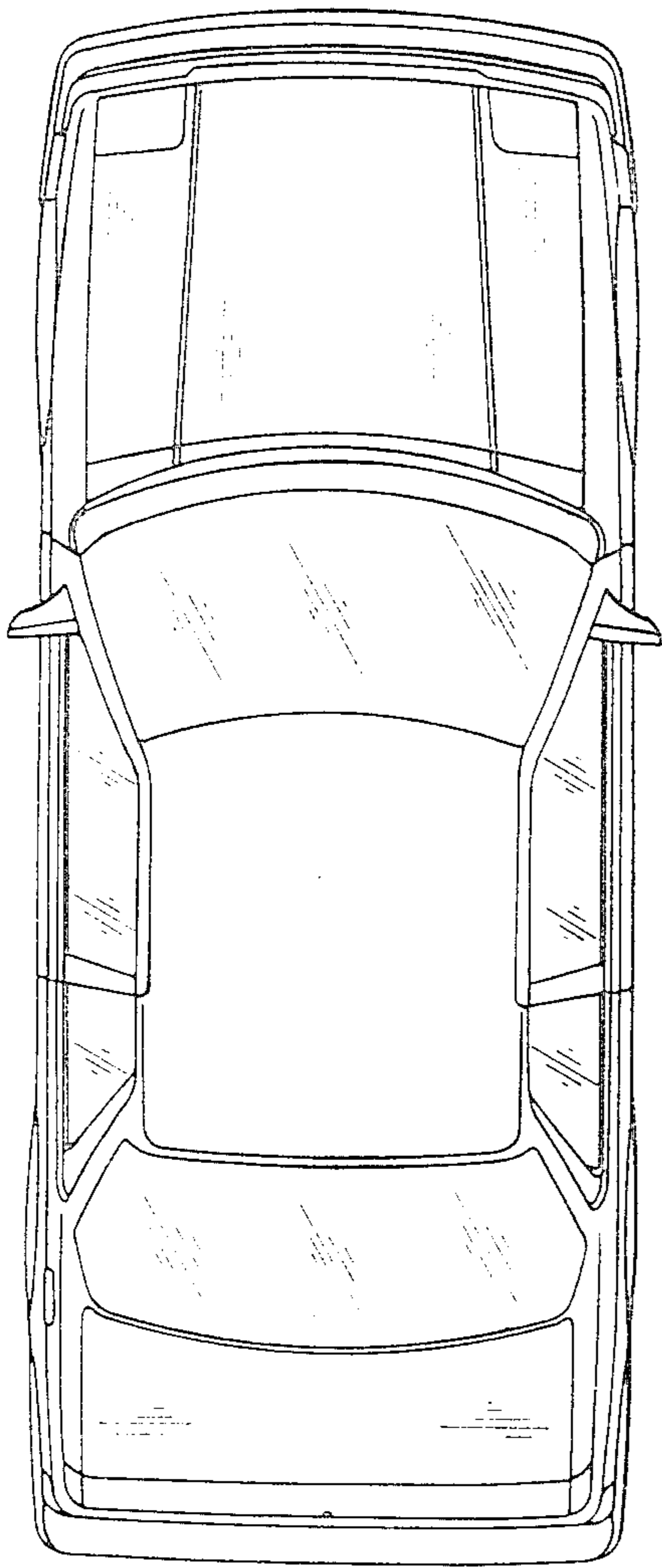

FIG. 1.

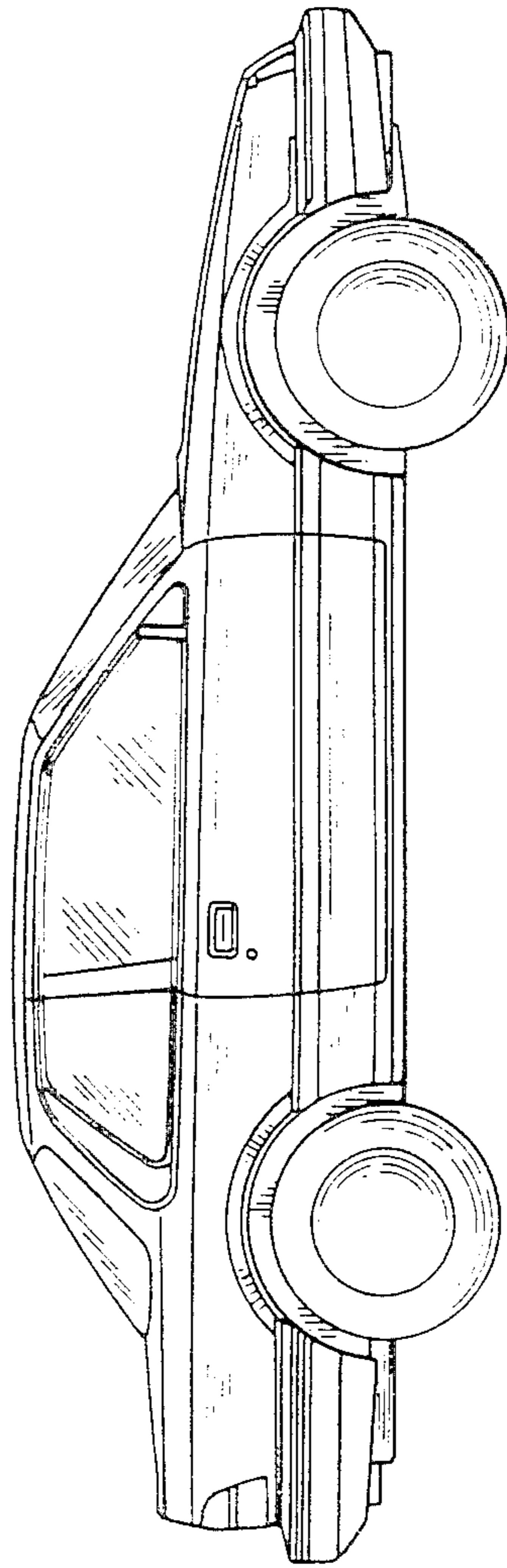

FIG. 2.

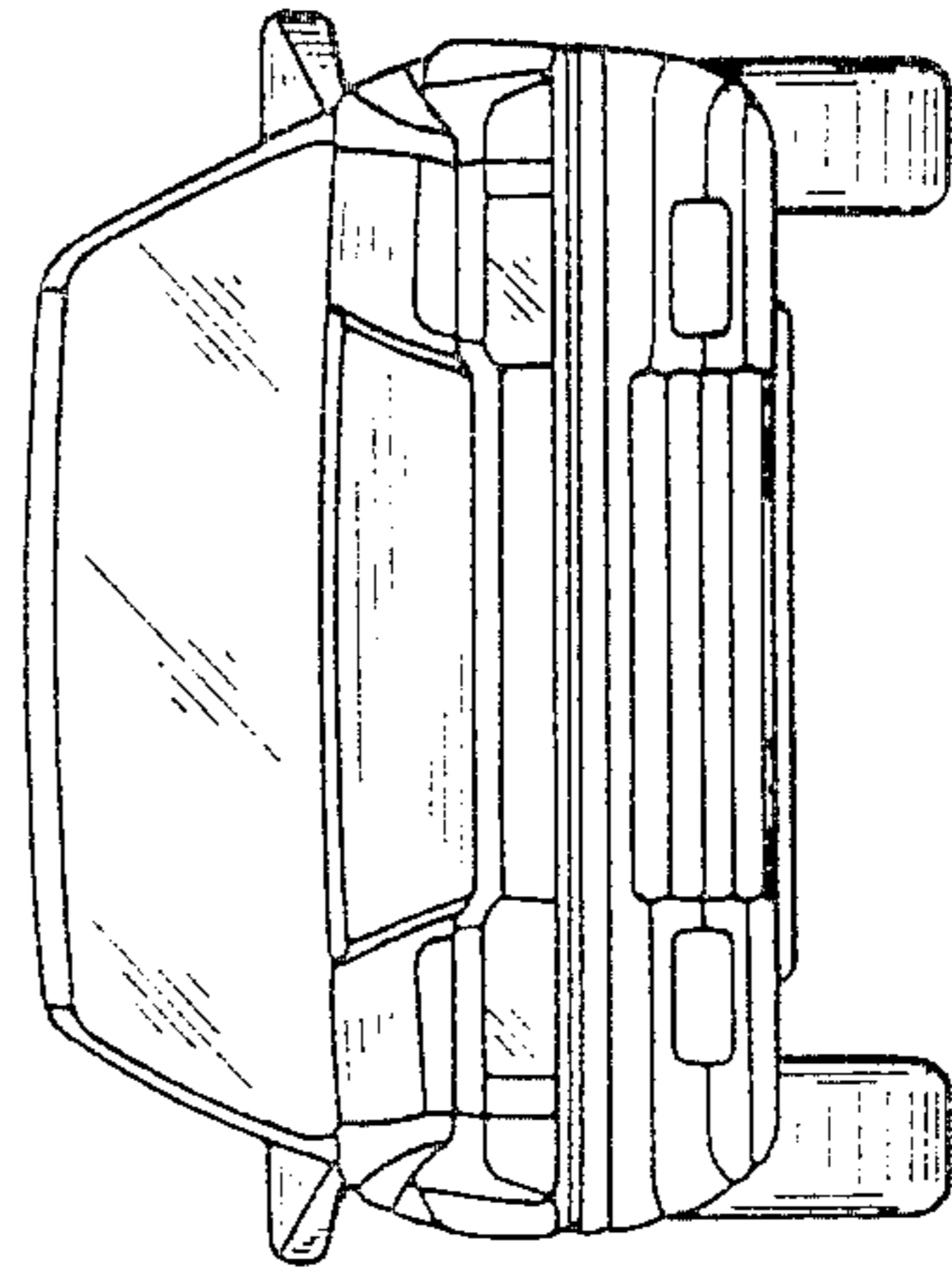

FIG. 3.

FIG. 5.

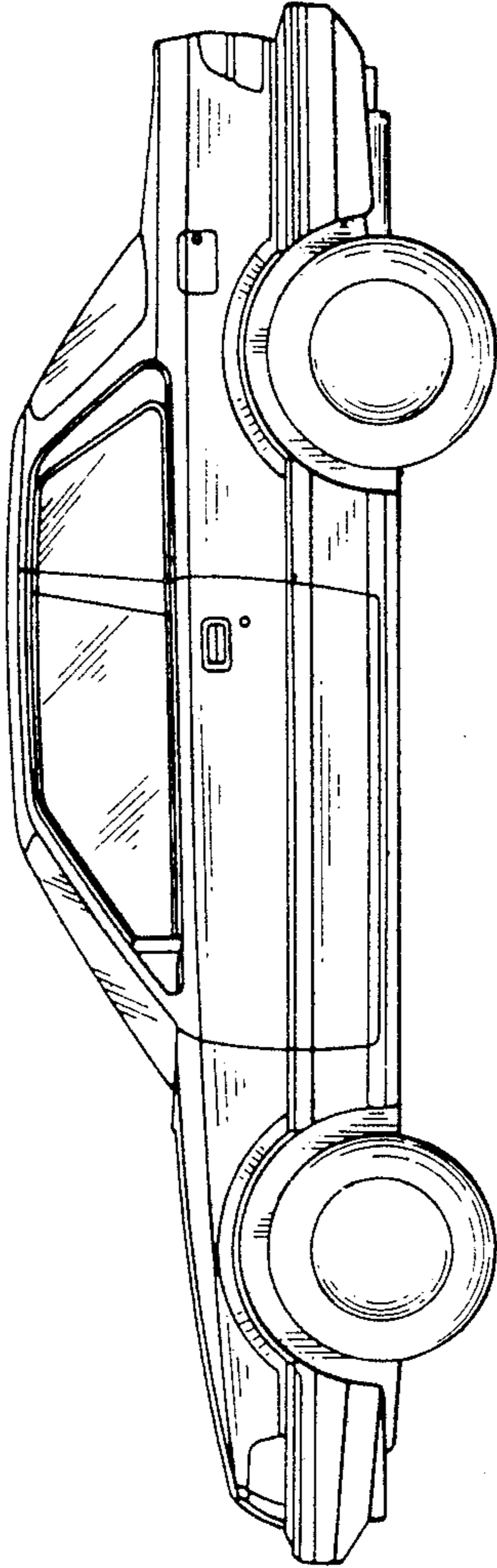

FIG. 4.

