

[54] COMBINED TOY VEHICLE AND RIDER FIGURE

[75] Inventors: Kunio Miyazaki; Shiro Ito, both of Tokyo, Japan

[73] Assignee: Tomy Kogyo Co., Inc., Tokyo, Japan

[**] Term: 14 Years

[21] Appl. No.: 402,363

[22] Filed: Jul. 27, 1982

[30] Foreign Application Priority Data

Jan. 29, 1982 [JP] Japan 57/3765

[52] U.S. Cl. D21/134; D21/150; D21/171

[58] Field of Search D21/134, 137, 128, 150, D21/76, 81, 171, 177, 178; 46/211, 201, 202, 204, 116

[56] References Cited

U.S. PATENT DOCUMENTS

D. 269,099 5/1983 Goldfarb et al. D21/134
2,091,872 8/1937 Muller 46/211

OTHER PUBLICATIONS

Hong Kong Toys, 1980, p. 32, Petrel Toys, upper left, item No. 9230, Suzuki.

Primary Examiner—Melvin B. Feifer
Attorney, Agent, or Firm—Staas & Halsey

[57] CLAIM

The ornamental design for a combined toy vehicle and rider figure, as shown.

DESCRIPTION

FIG. 1 is a front elevational view of a combined toy vehicle and rider figure showing our new design; FIG. 2 is a rear elevational view thereof; FIG. 3 is a top plan view thereof; FIG. 4 is a bottom plan view thereof; FIG. 5 is a right side elevational view thereof; and FIG. 6 is a left side elevational view thereof.

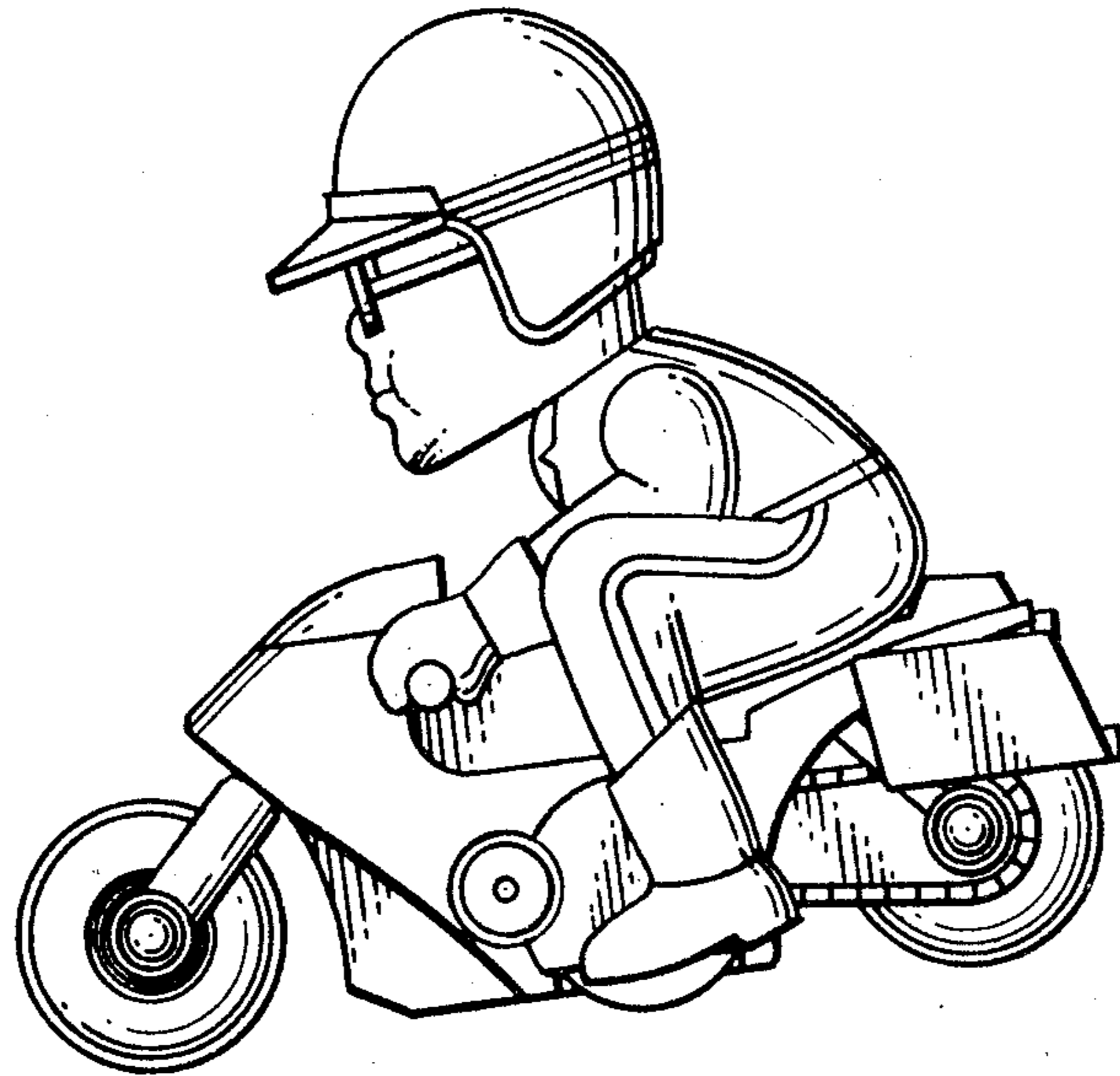

FIG. 1.

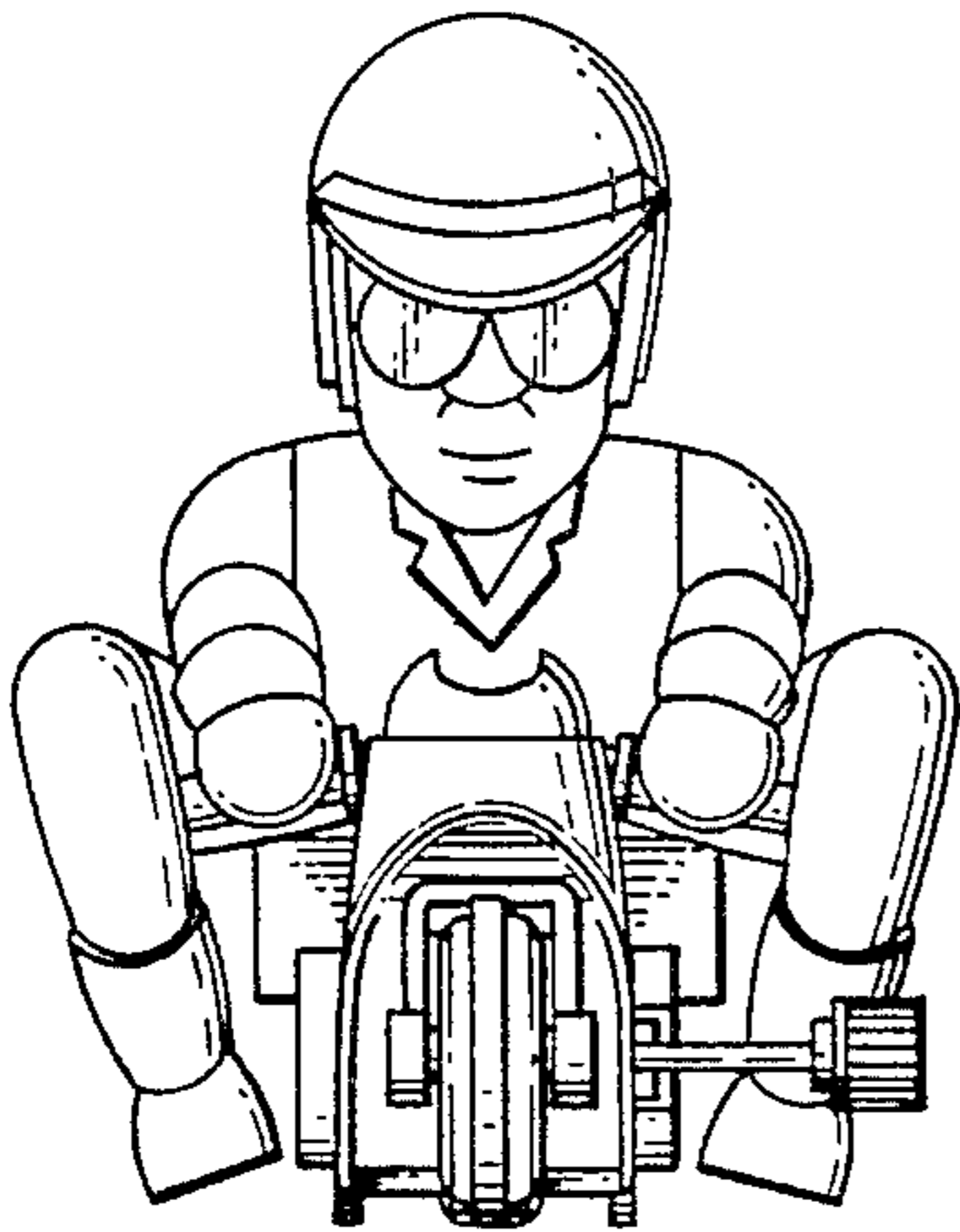

FIG. 2.

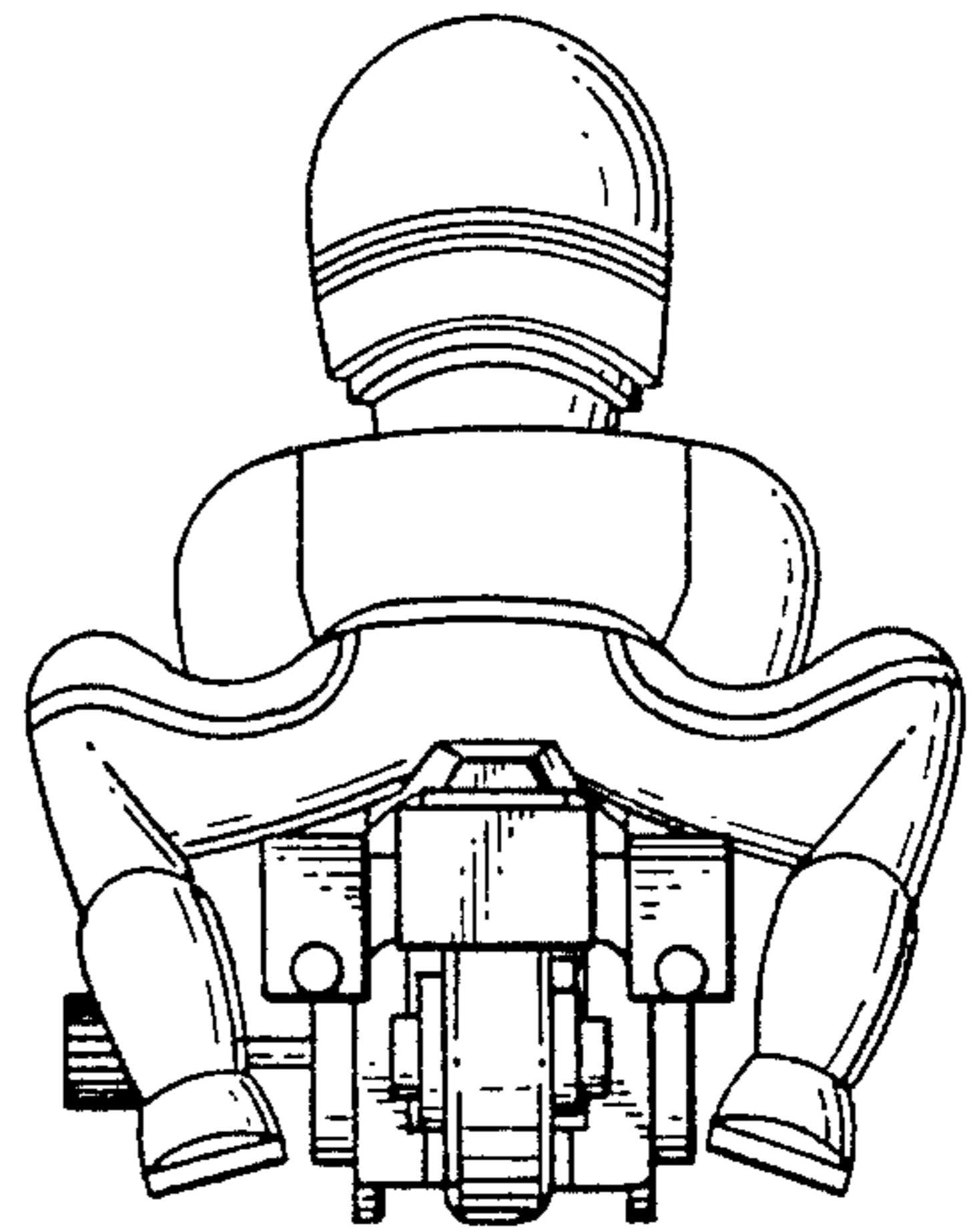

FIG. 3.

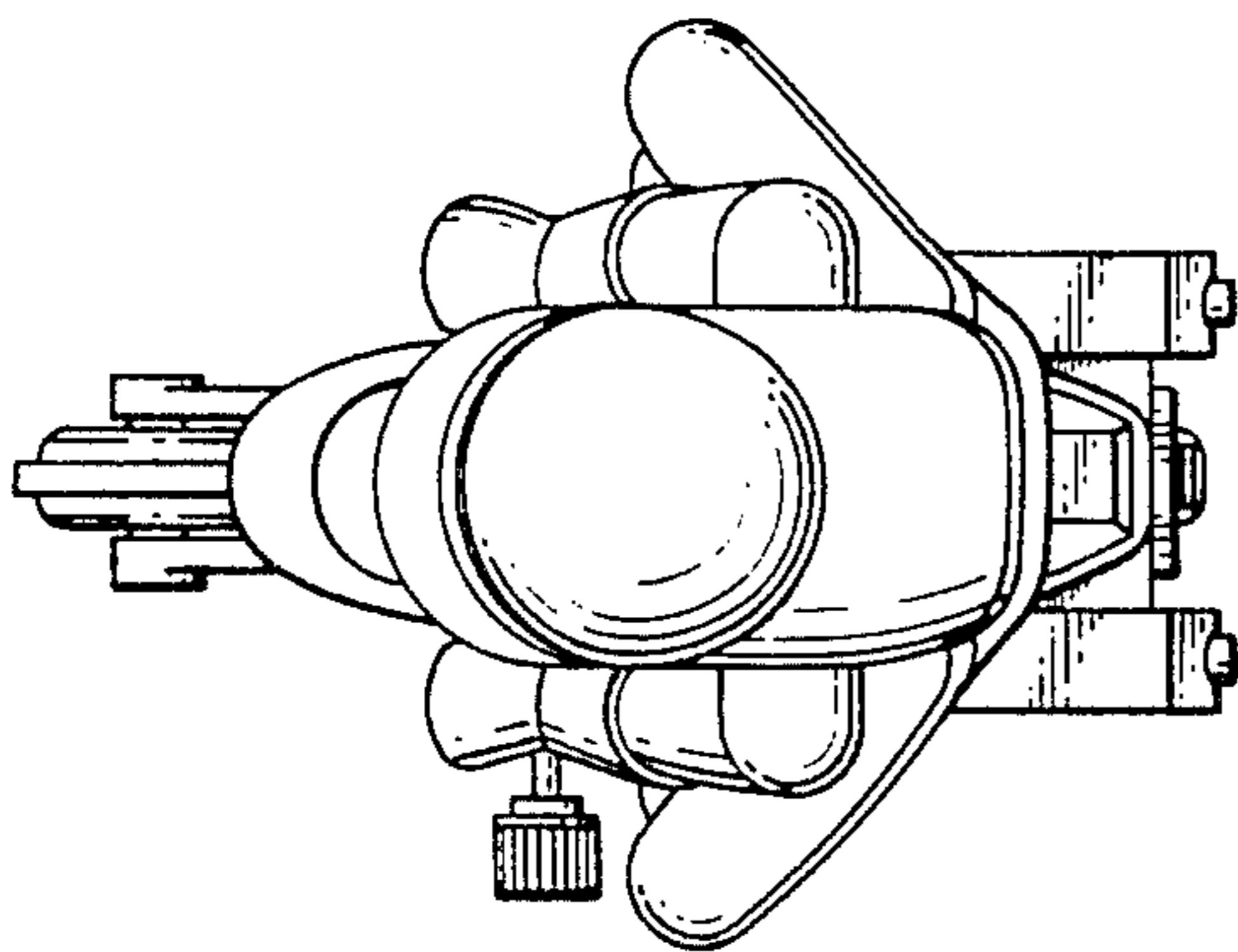

FIG. 4.

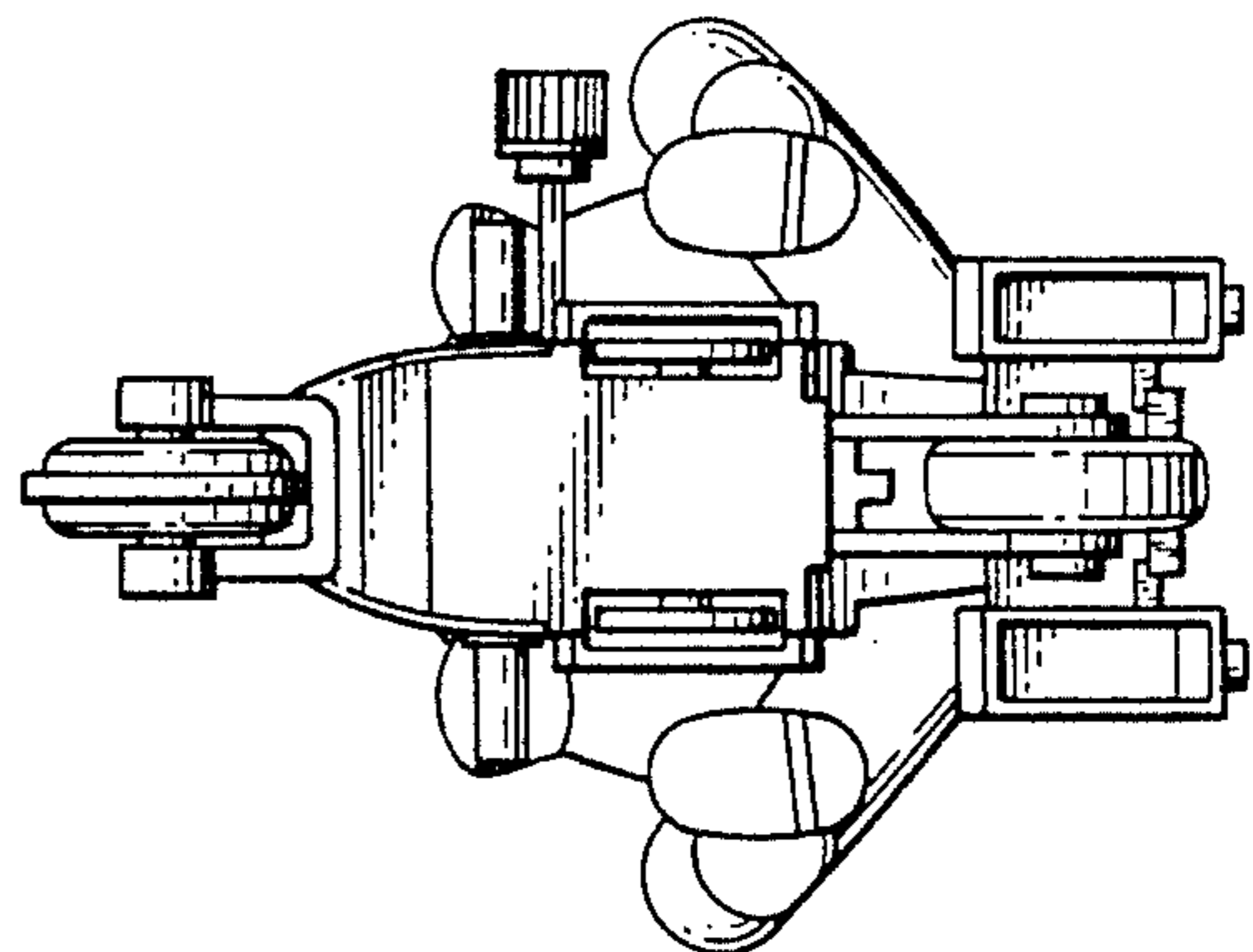

FIG. 5.

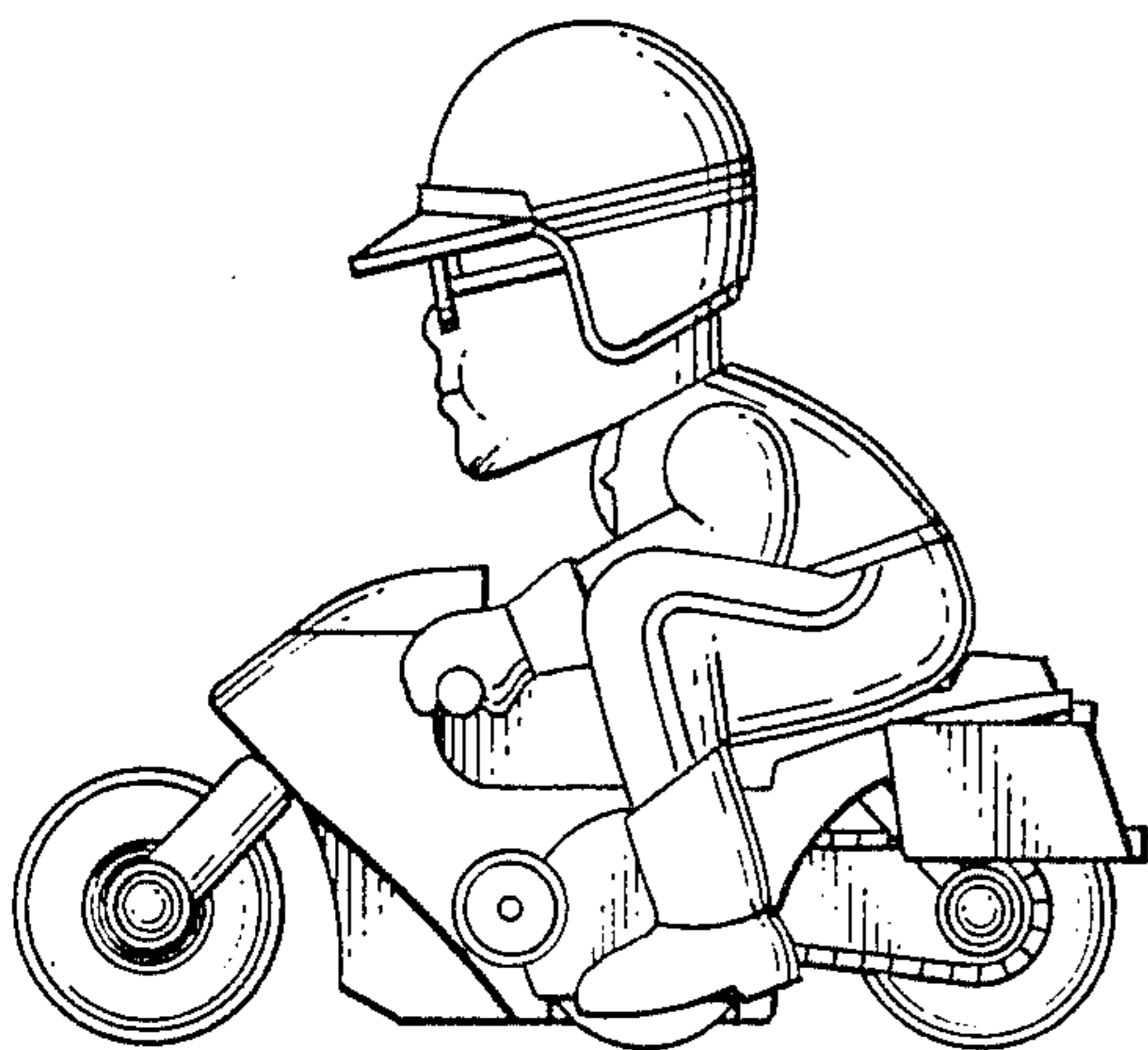

FIG. 6.

