

[54] **VIDEO ARCADE GAME AND DISPLAY HOUSING**

[75] **Inventors: Jay Smith, III, Pacific Palisades; Moto Shimano, Los Angeles, both of Calif.**

[73] **Assignee: Smith Engineering, Culver City, Calif.**

[**] **Term: 14 Years**

[21] **Appl. No.: 350,462**

[22] **Filed: Jan. 6, 1982**

[52] **U.S. Cl. D21/13; D14/80**

[58] **Field of Search D21/13; D14/80; 273/DIG. 28, 85 G, 1 GC**

[56] **References Cited**
U.S. PATENT DOCUMENTS

- D. 237,739 11/1975 Itoh D14/80
- D. 238,511 1/1976 Boldt D14/80
- D. 245,025 7/1977 Smith et al. D14/80

Primary Examiner—Melvin B. Feifer
Attorney, Agent, or Firm—Jackson, Jones & Price

[57] **CLAIM**

The ornamental design for a video arcade game and display housing, substantially as shown.

DESCRIPTION

- FIG. 1 is a perspective view of the video arcade game and display housing showing our new design;
- FIG. 2 is a right side view;
- FIG. 3 is a front elevational view;
- FIG. 4 is a left side elevational view;
- FIG. 5 is the rear elevational view;
- FIG. 6 is a top plan view;
- FIG. 7 is a bottom plan view.

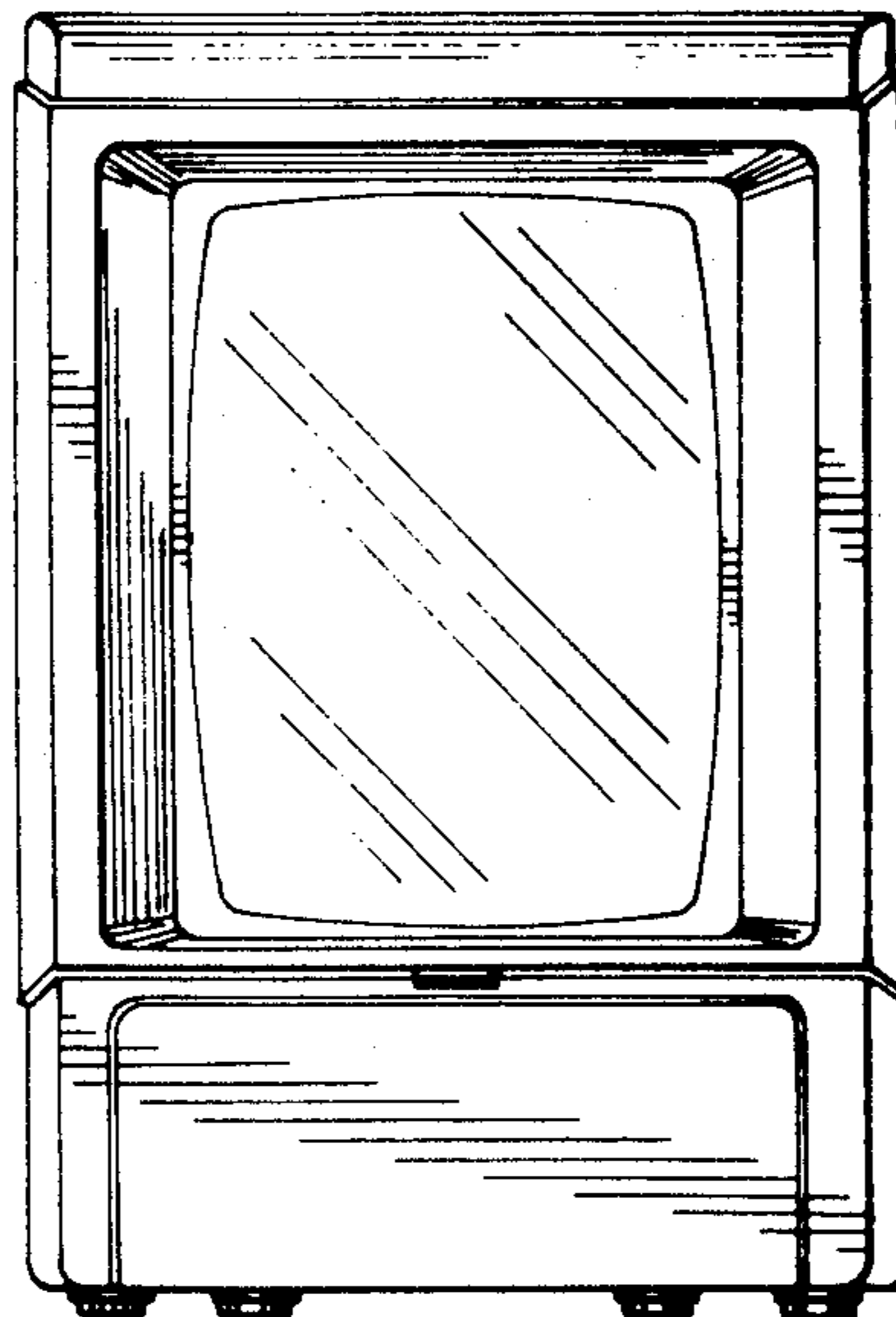

FIG. 1

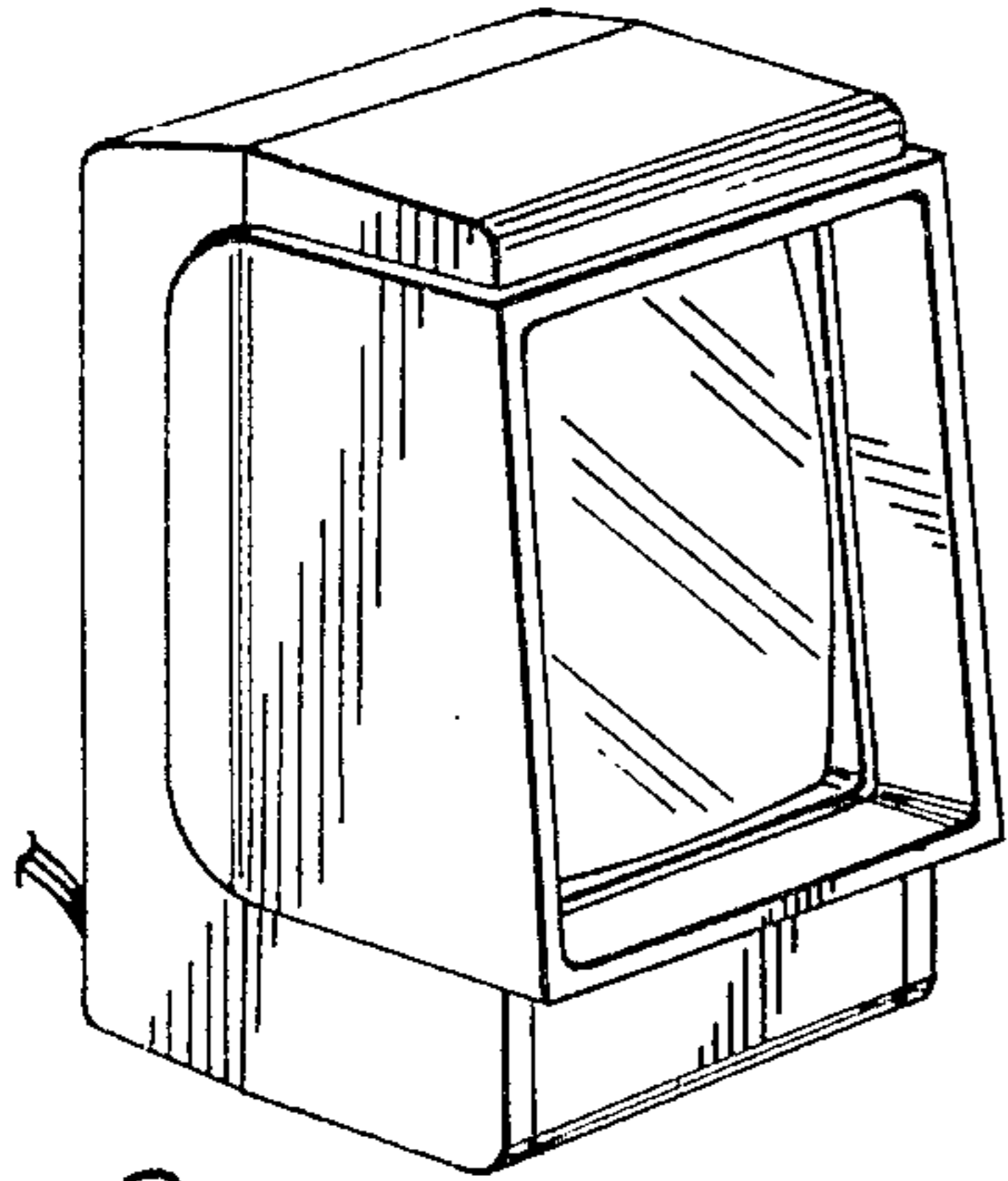

FIG. 2

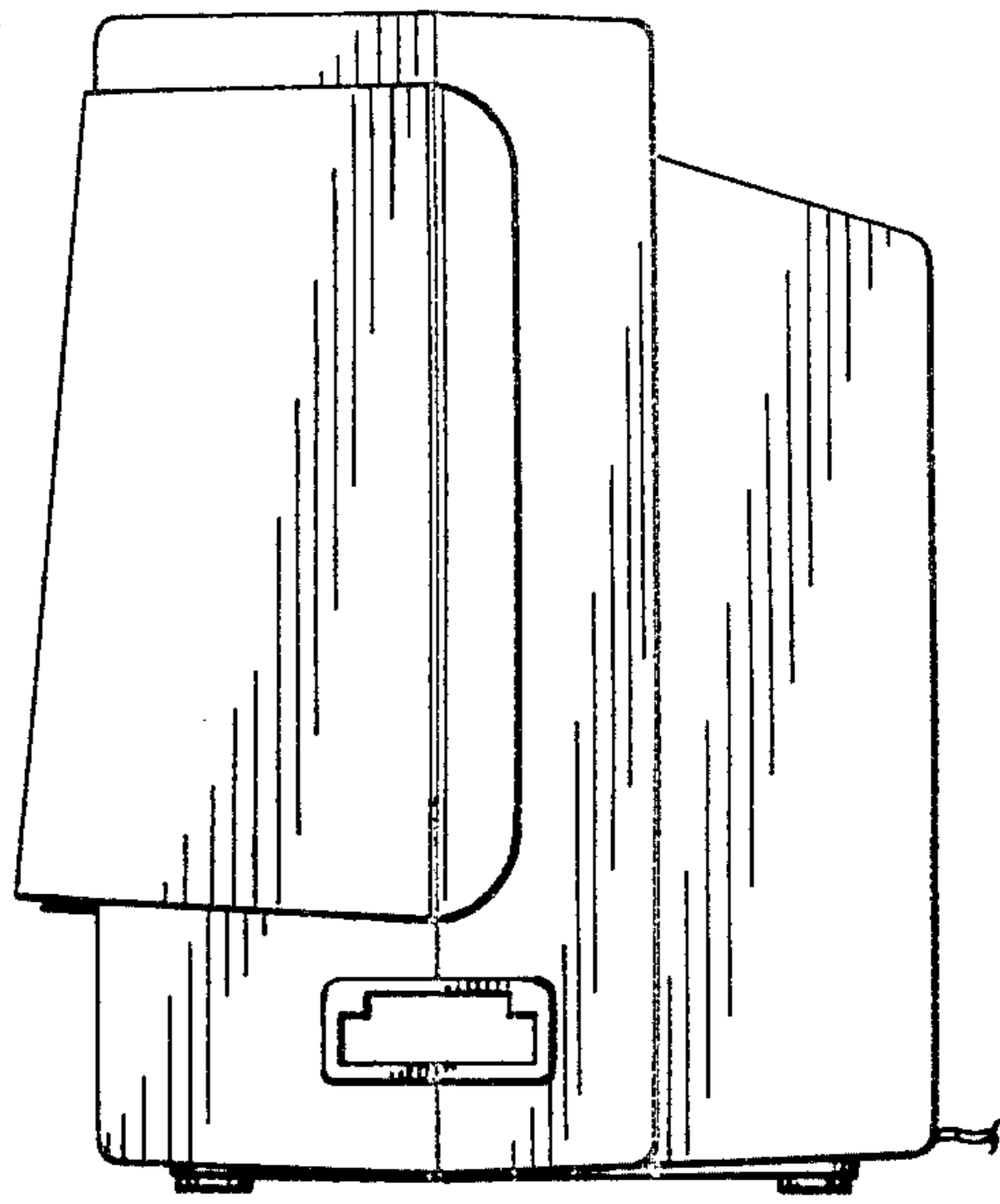

FIG. 3

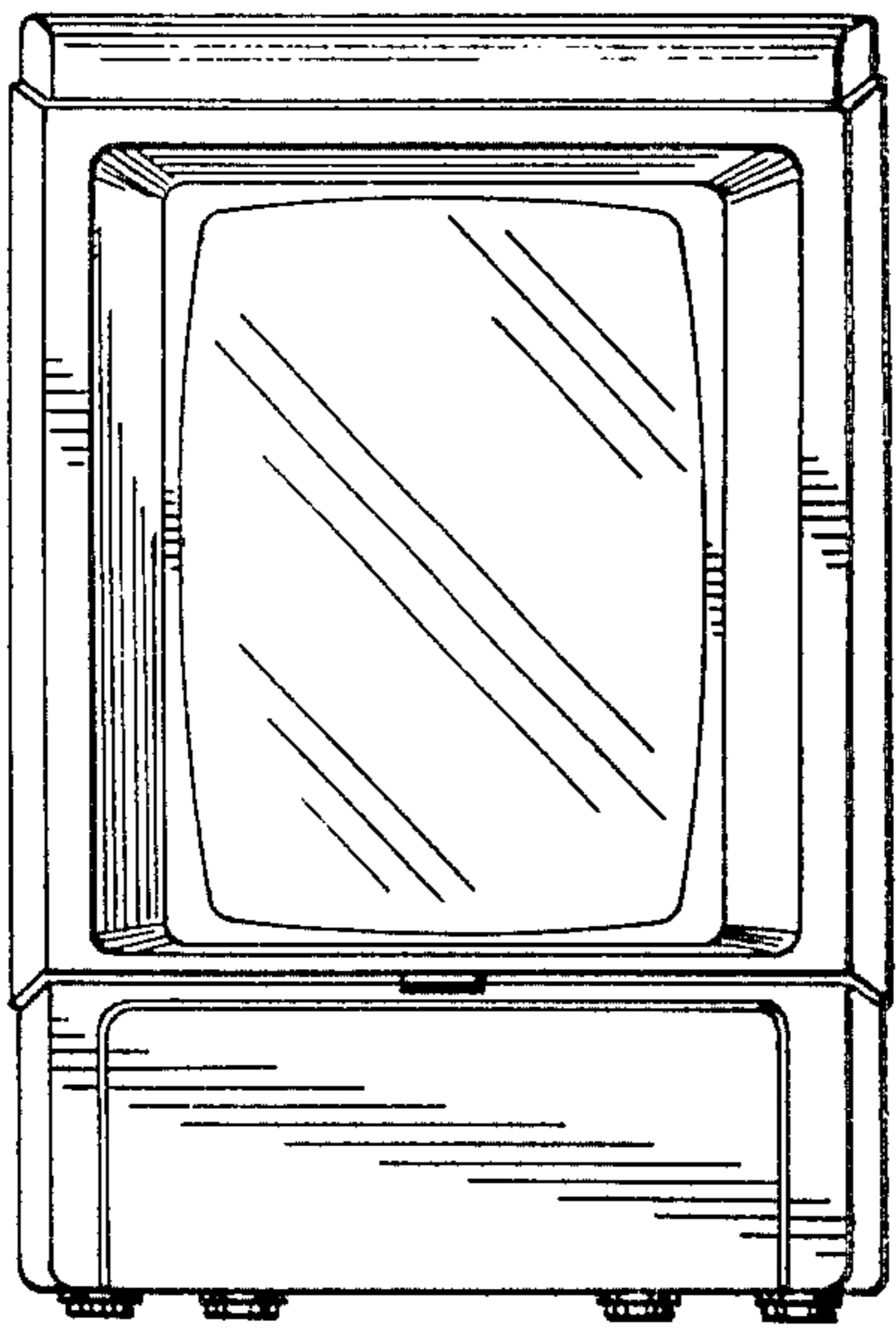

FIG. 4

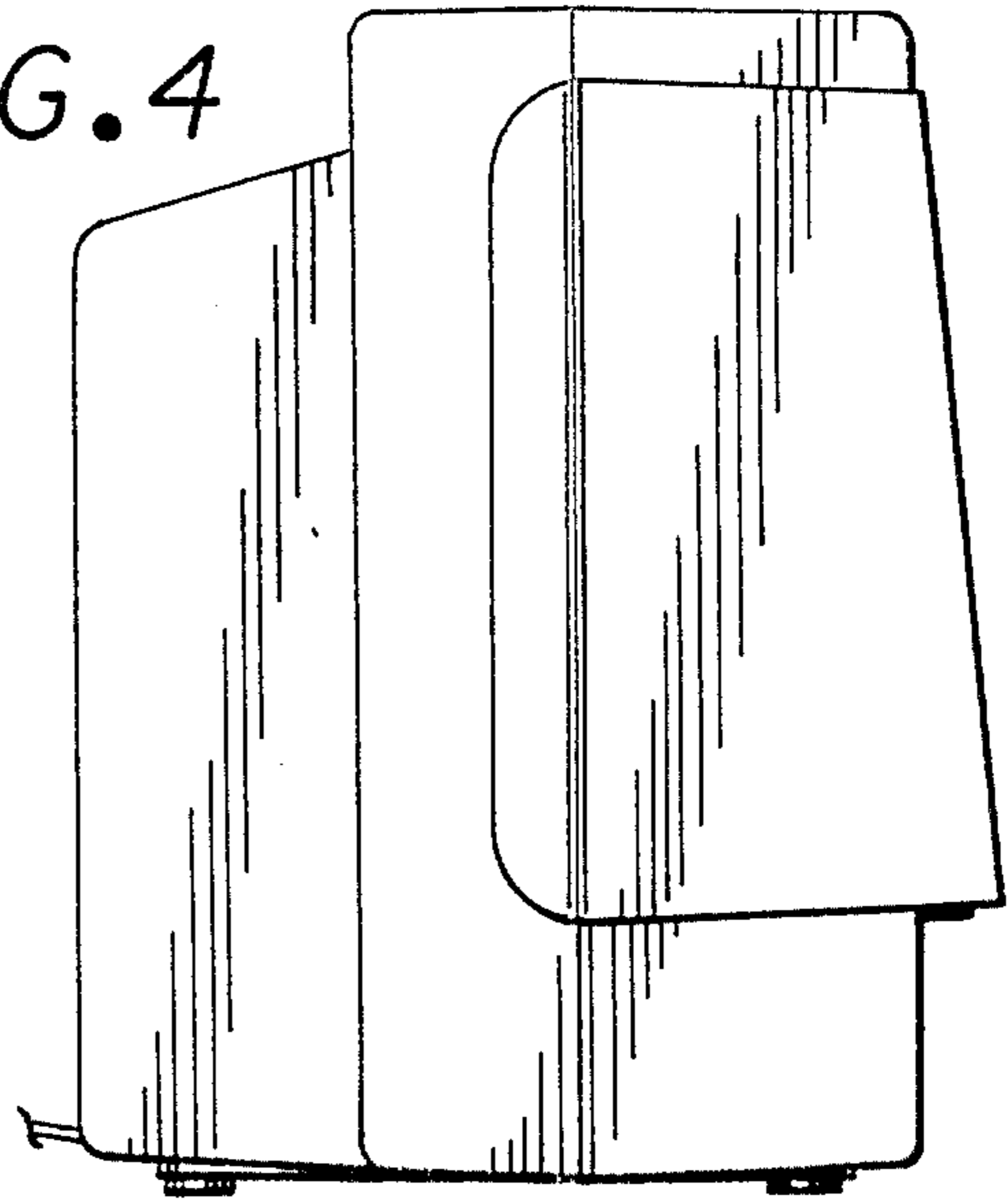

FIG. 5

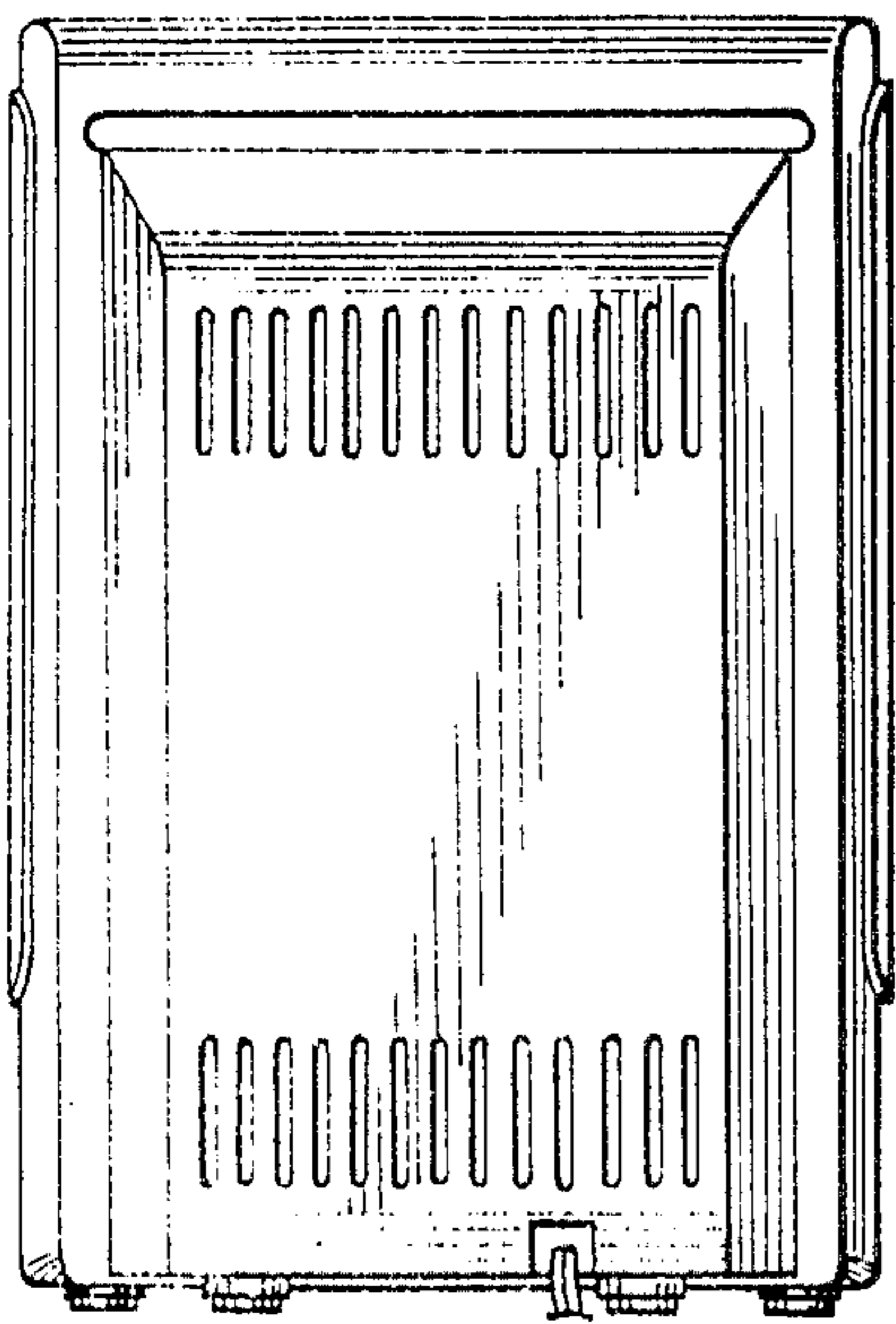

FIG. 6

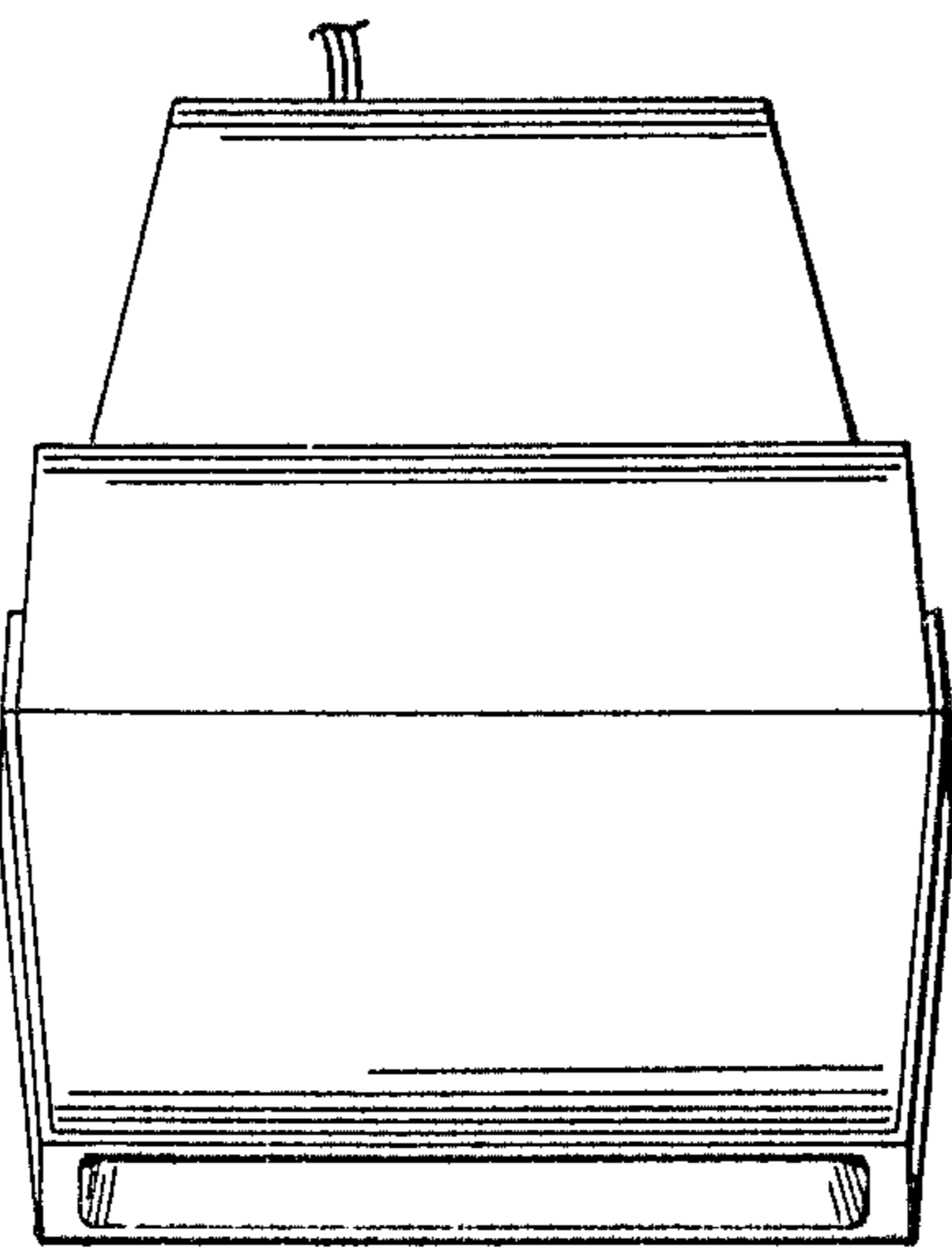

FIG. 7

