

[54] **IMPACT DRIVE SPRINKLER**

[75] Inventors: **Richard D. Brown**, Glendora; **Hans D. Christen**, La Verne, both of Calif.

[73] Assignee: **Rain Bird Sprinkler Mfg. Corp.**, Glendora, Calif.

[\*\*] Term: **14 Years**

[21] Appl. No.: **352,323**

[22] Filed: **Feb. 25, 1982**

[52] U.S. Cl. .... **D23/7**

[58] Field of Search ..... **D23/6-10;**  
**239/230, 231, 232, 233**

3,930,617 1/1976 Dunmire ..... 239/233 X  
 3,957,205 5/1976 Costa ..... 239/230  
 3,968,934 7/1976 Healy ..... 239/230  
 4,177,944 12/1979 Wichman .  
 4,205,788 6/1980 Bruninga ..... 239/233

*Primary Examiner*—James R. Largen  
*Attorney, Agent, or Firm*—Fulwider, Patton, Rieber,  
 Lee & Utecht

[57] **CLAIM**

The ornamental design for an impact drive sprinkler, substantially as shown and described.

**DESCRIPTION**

FIG. 1 is a perspective view of an impact drive sprinkler embodying our new design;  
 FIG. 2 is a left side elevational view thereof;  
 FIG. 3 is a front elevational view thereof;  
 FIG. 4 is a rear elevational view thereof;  
 FIG. 5 is a top plan view thereof;  
 FIG. 6 is a bottom plan view thereof;  
 FIG. 7 is a right side elevational view thereof;  
 FIG. 8 is a perspective view of a modified form of the impact drive sprinkler shown in FIG. 1;  
 FIG. 9 is a left side elevational view of FIG. 8;  
 FIG. 10 is a front elevational view of FIG. 8;  
 FIG. 11 is a rear elevational view of FIG. 8;  
 FIG. 12 is a top plan view of FIG. 8;  
 FIG. 13 is a bottom plan view of FIG. 8; and  
 FIG. 14 is a right side elevational view of FIG. 8.

[56] **References Cited**

**U.S. PATENT DOCUMENTS**

D. 255,825	7/1980	Hardy	.....	D23/7
D. 266,449	10/1982	Foreman	.....	D23/7
D. 270,178	8/1983	Heck	.....	D23/7
2,918,220	12/1959	Crow	.	
2,981,482	4/1961	Warren	.	
3,043,522	7/1962	Ryerson	.....	239/230
3,080,123	3/1963	Erns	.	
3,103,313	9/1963	Raem	.	
3,193,203	7/1965	Crow	.	
3,244,373	4/1966	Hait	.	
3,856,207	12/1974	Rees, Jr.	.....	239/230
3,884,416	5/1975	King	.....	239/230
3,912,171	10/1975	Johnson	.	
3,918,642	11/1975	Best	.....	239/230

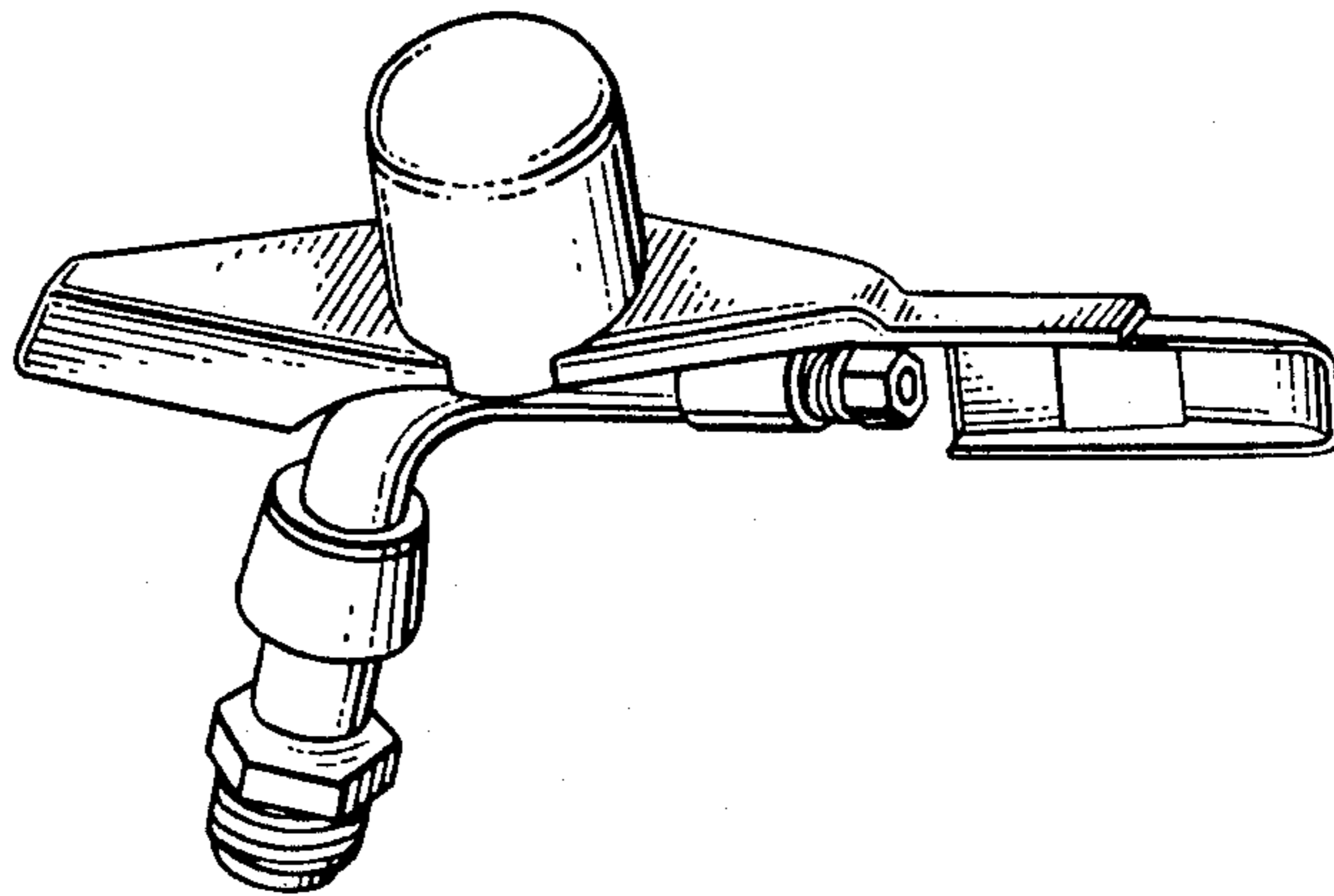

*Fig. 1*

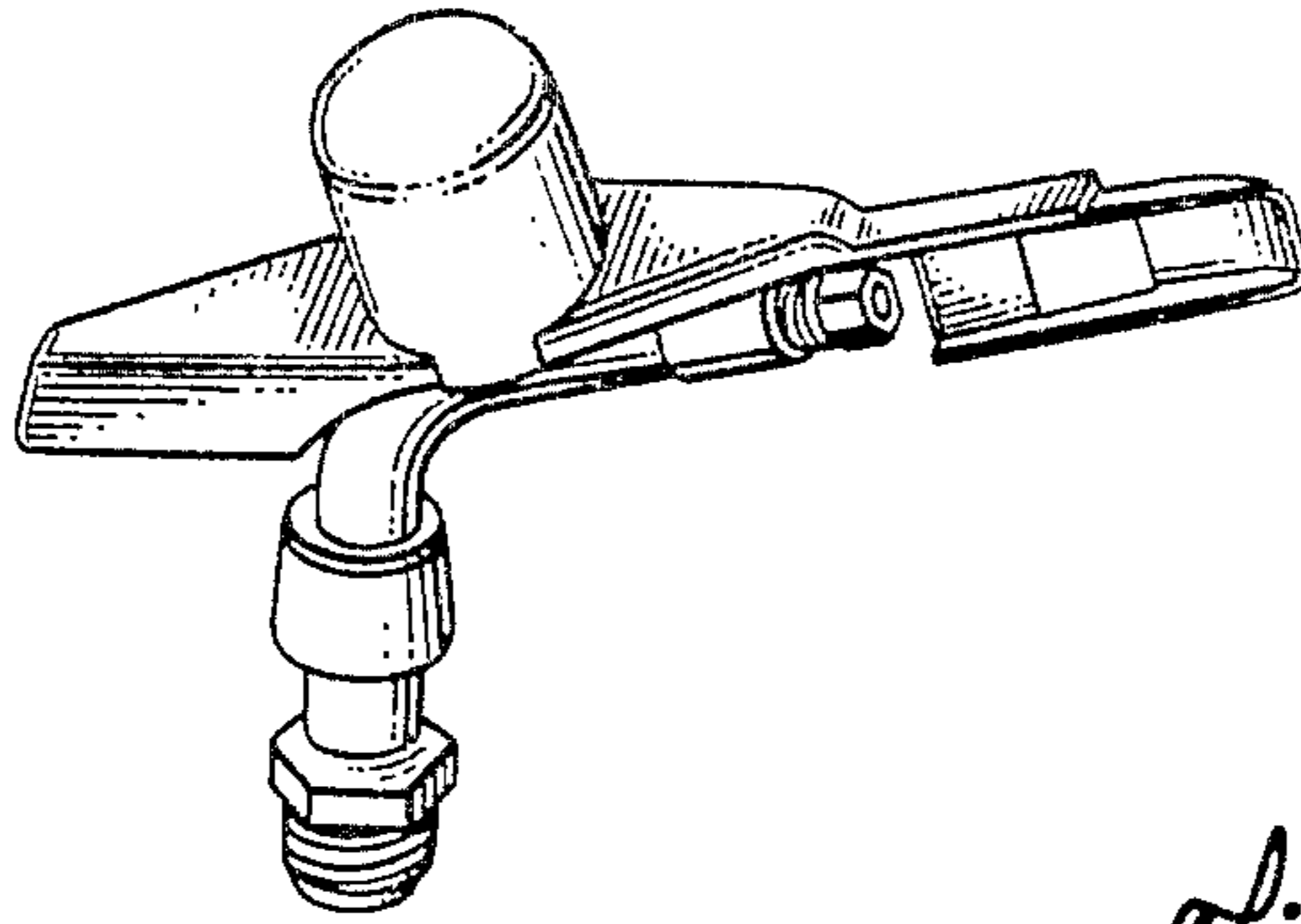

*Fig. 2*

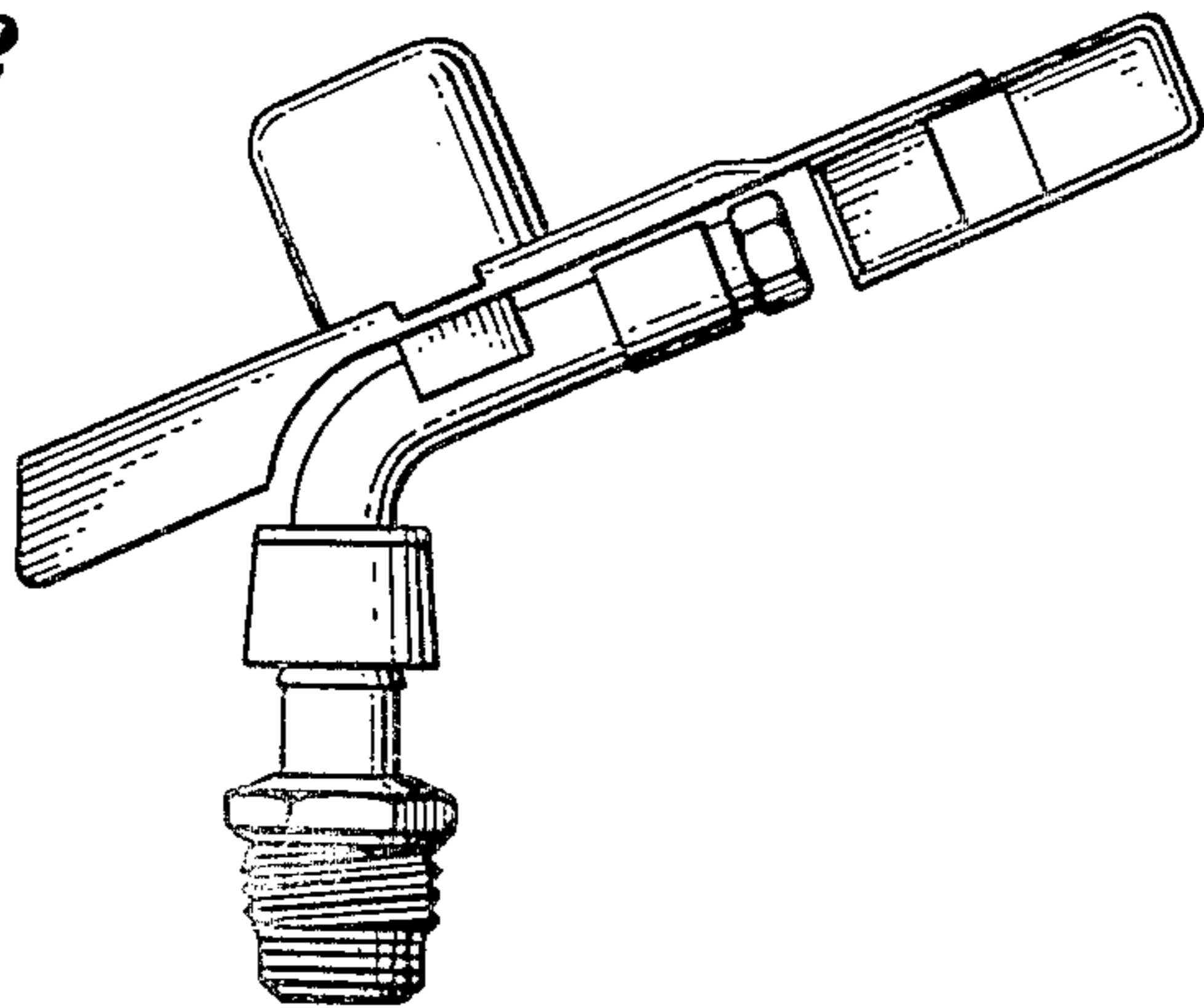

*Fig. 3*

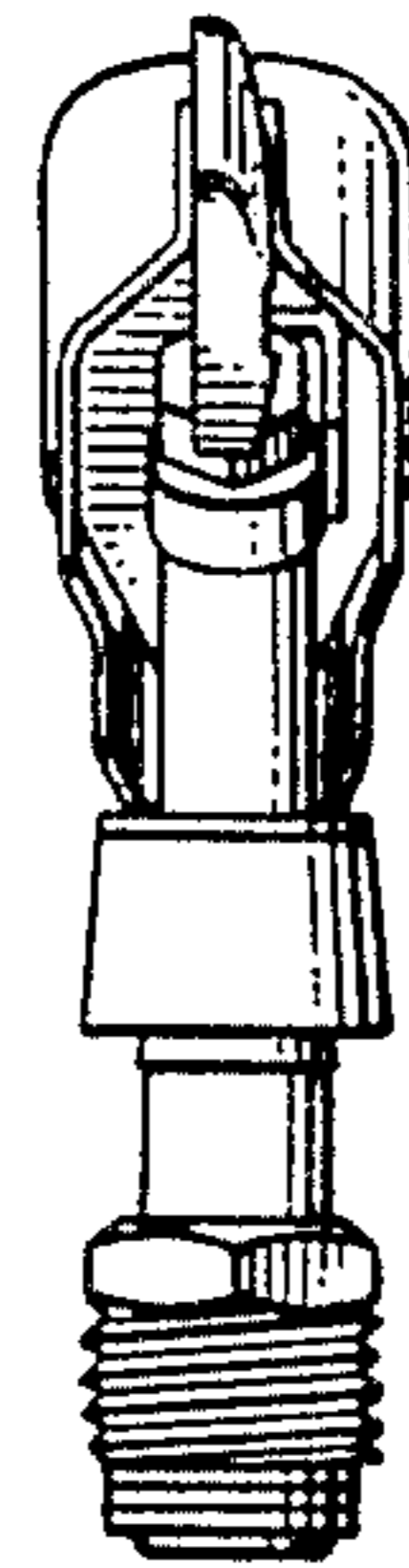

*Fig. 4*

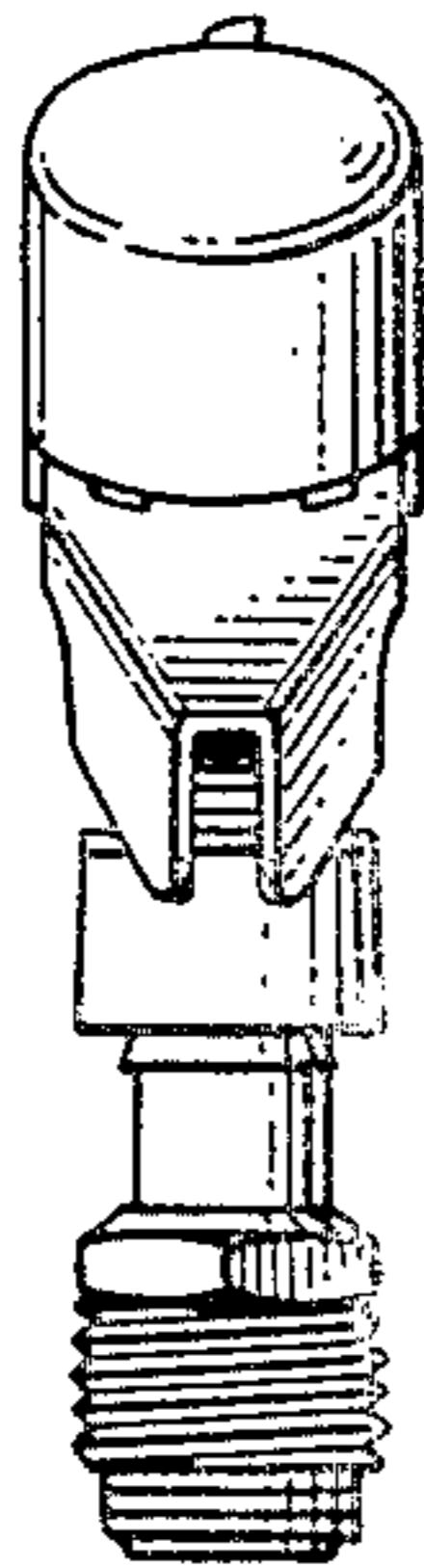

*Fig. 5*

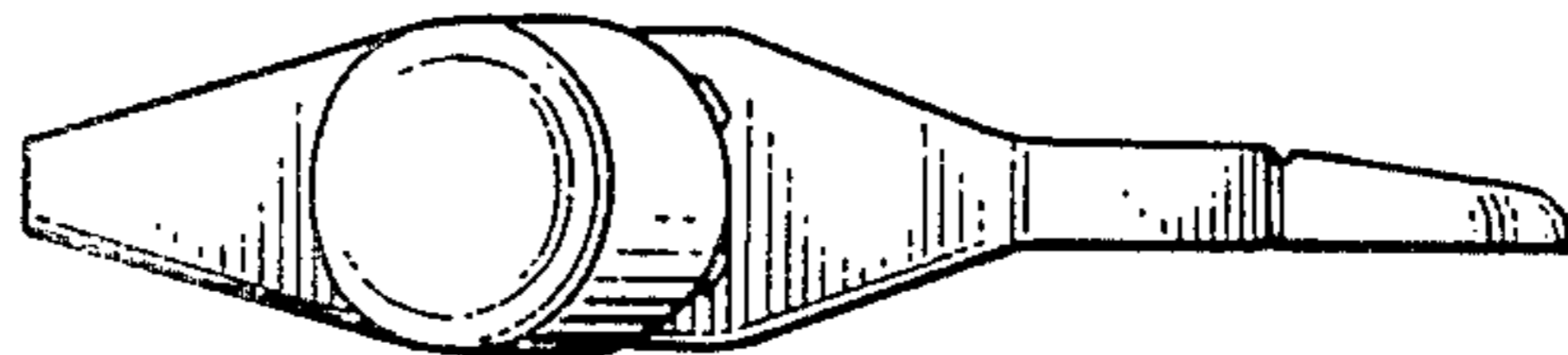

*Fig. 6*

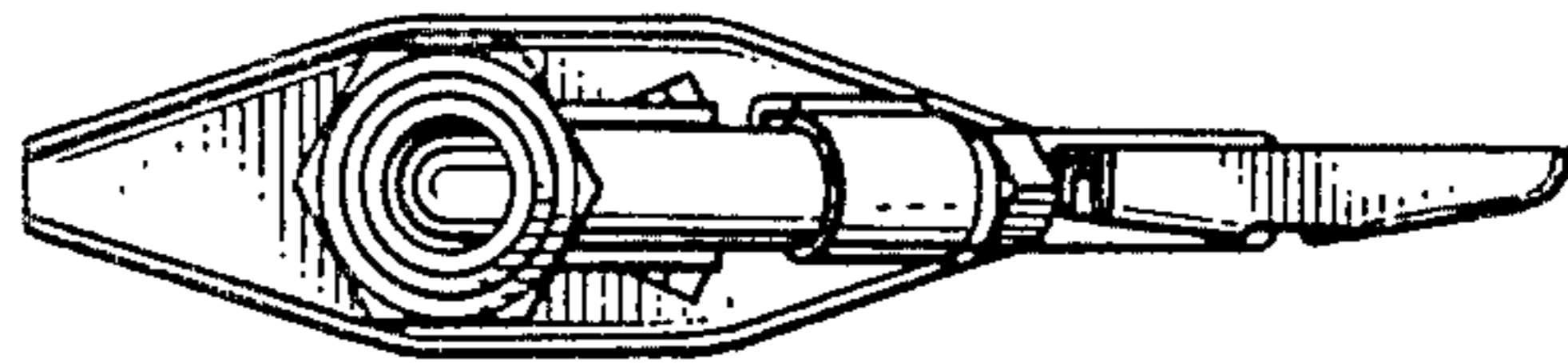

*Fig. 7*

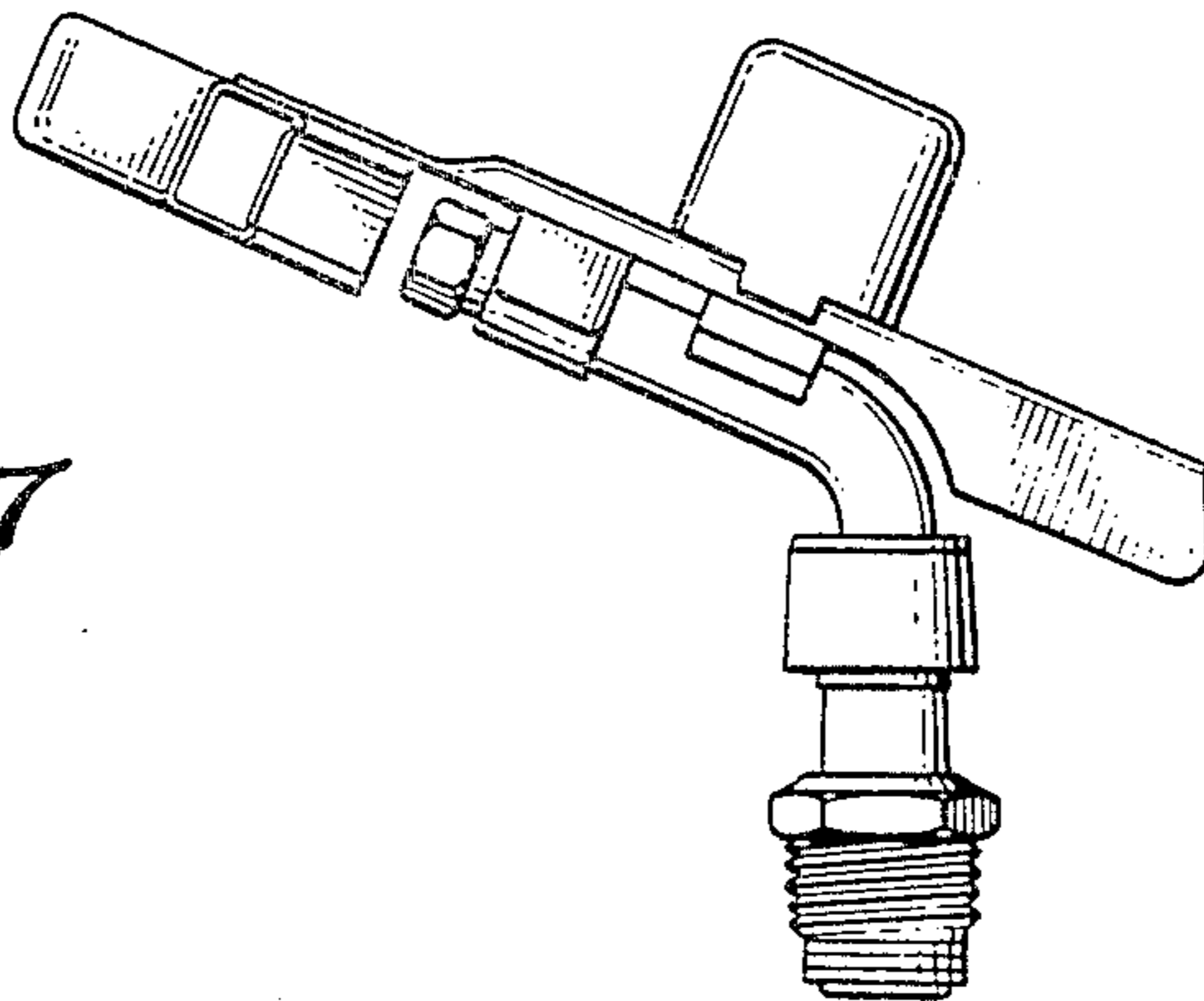

*Fig. 8*

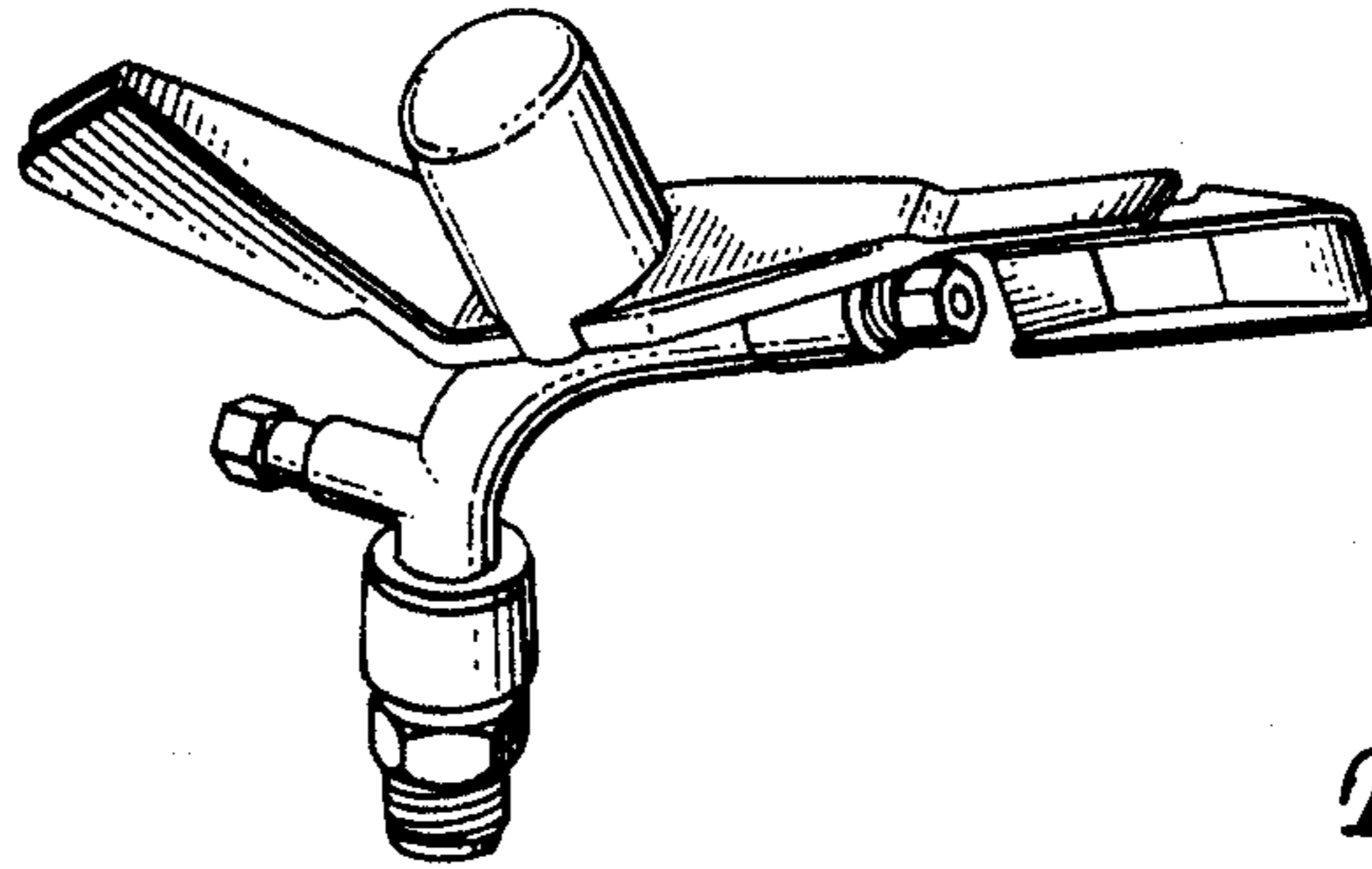

*Fig. 9*

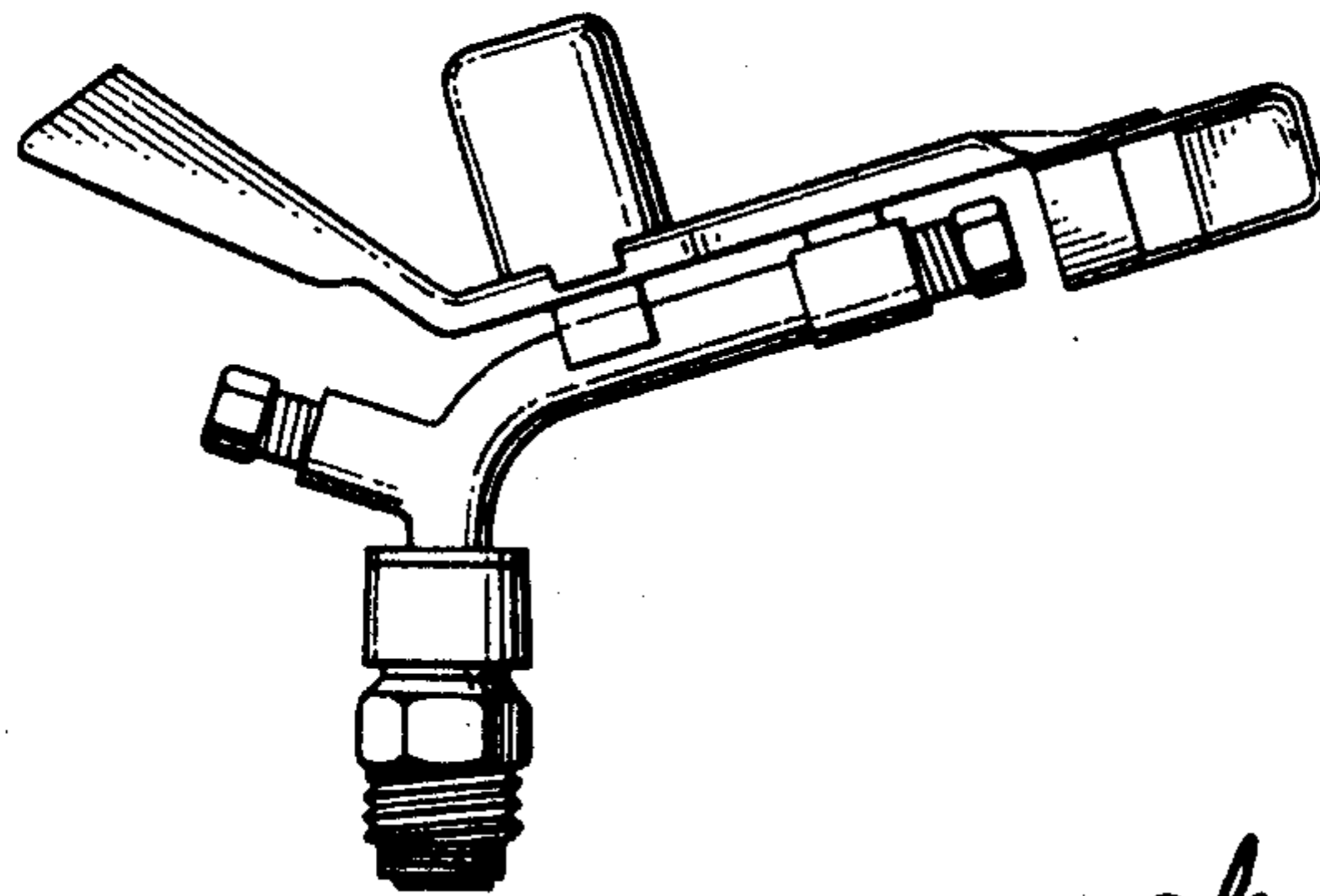

*Fig. 10*

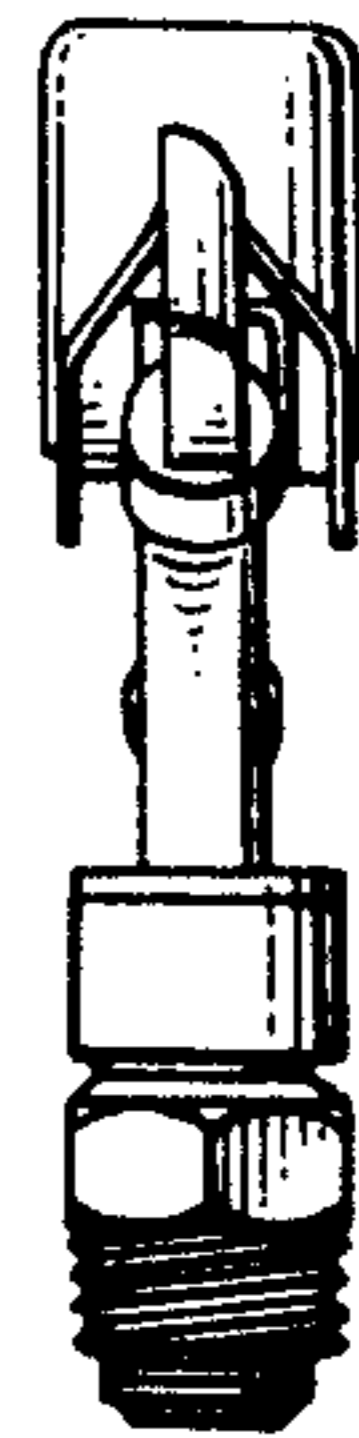

*Fig. 12*



*Fig. 11*

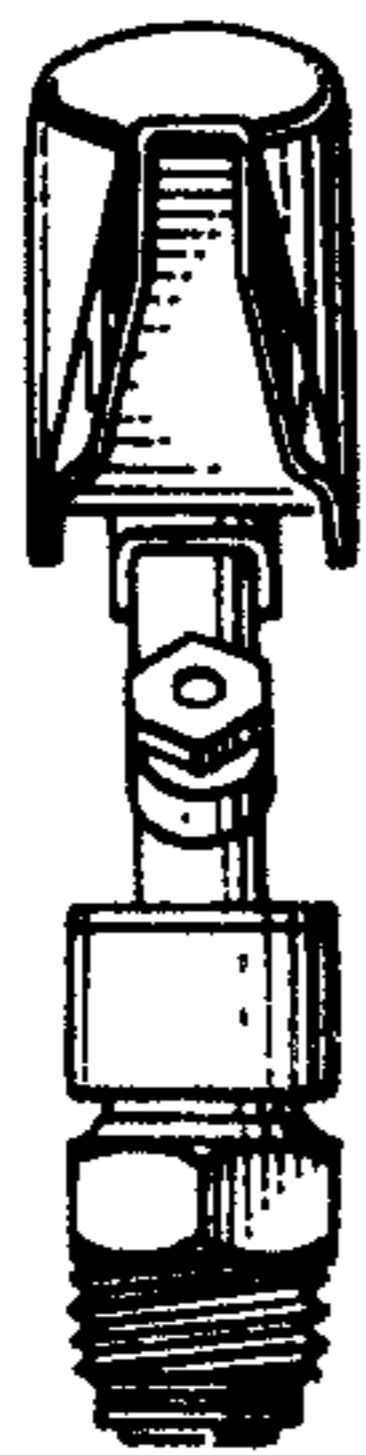

*Fig. 13*

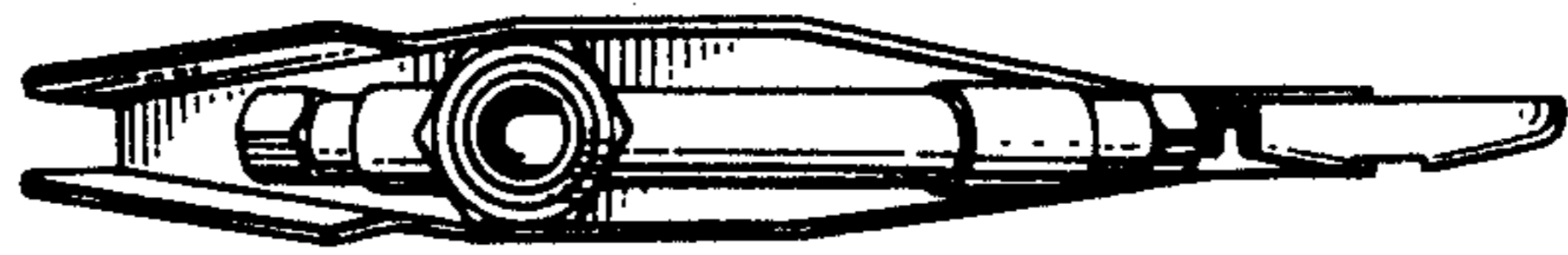

*Fig. 14*

