

United States Patent [19]

Shaw

[11] Patent Number: **Des. 276,421**

[45] Date of Patent: **** Nov. 20, 1984**

[54] **AUTOMOBILE TURN SIGNAL LEVER WITH TOGGLE SWITCHES**

[75] Inventor: **Mark L. Shaw, Fort Worth, Tex.**

[73] Assignee: **Specific Cruise Systems, Inc., Ft. Worth, Tex.**

[**] Term: **14 Years**

[21] Appl. No.: **453,515**

[22] Filed: **Dec. 27, 1982**

[52] U.S. Cl. **D12/174**

[58] Field of Search **D12/174, 177, 155; 200/61.27, 61.54; 180/333, 78**

[56] **References Cited**

U.S. PATENT DOCUMENTS

D. 256,575 8/1980 Moore D12/174

2,593,337 4/1952 O'Brien 200/61.54
4,179,592 12/1979 Nitsch 200/61.54

Primary Examiner—James M. Gandy
Attorney, Agent, or Firm—James E. Bradley

[57] CLAIM

The ornamental design for an automobile turn signal lever with toggle switches, as shown and described.

DESCRIPTION

FIG. 1 is a perspective view of an automobile turn signal lever with toggle switches embodying my new design.

FIG. 2 is an end elevation view thereof.

FIG. 3 is a perspective view thereof as seen from the side opposite the side shown in FIG. 1 and from the bottom.

FIG. 4 is a front elevation view thereof.

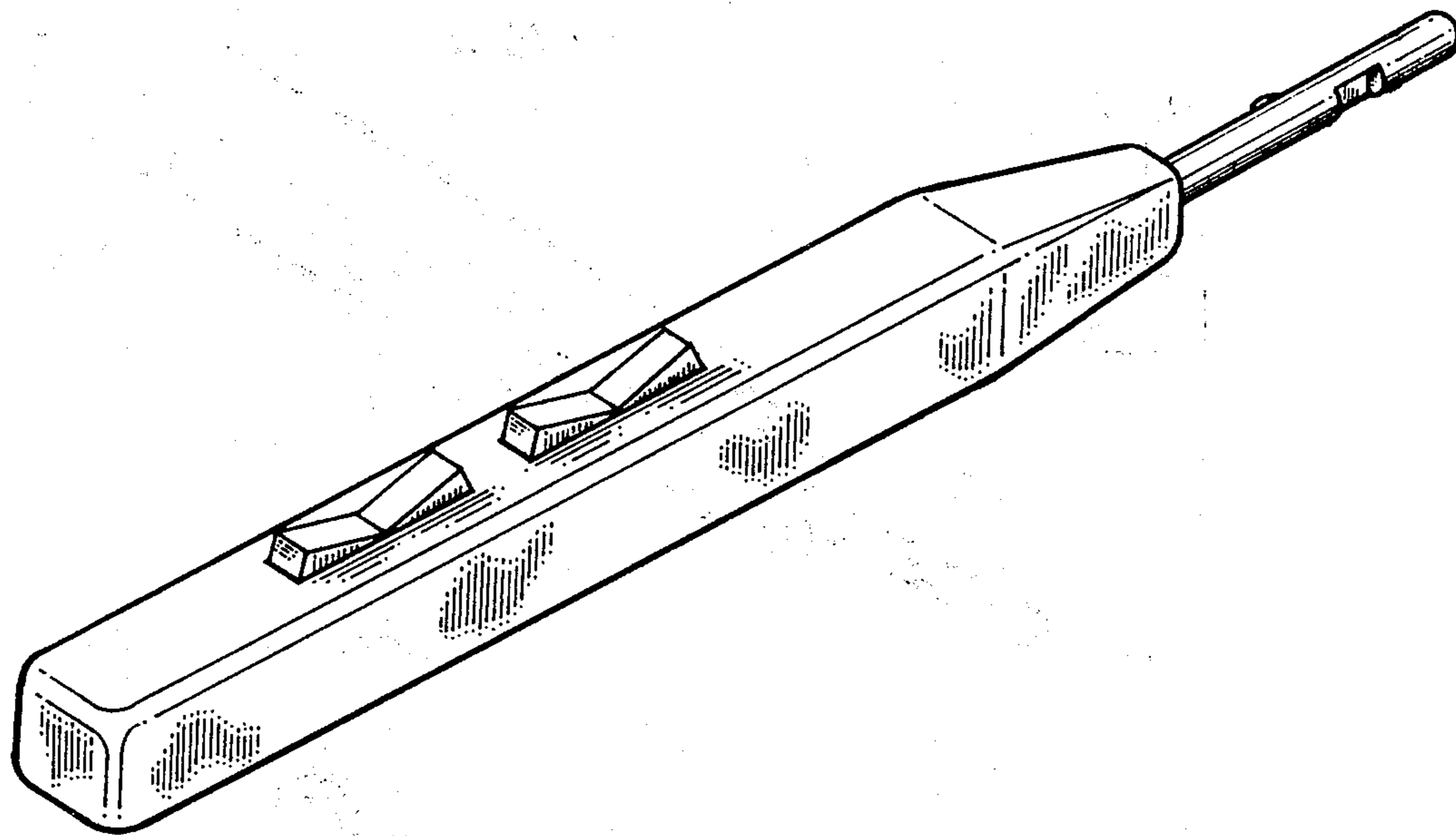

FIG. 1

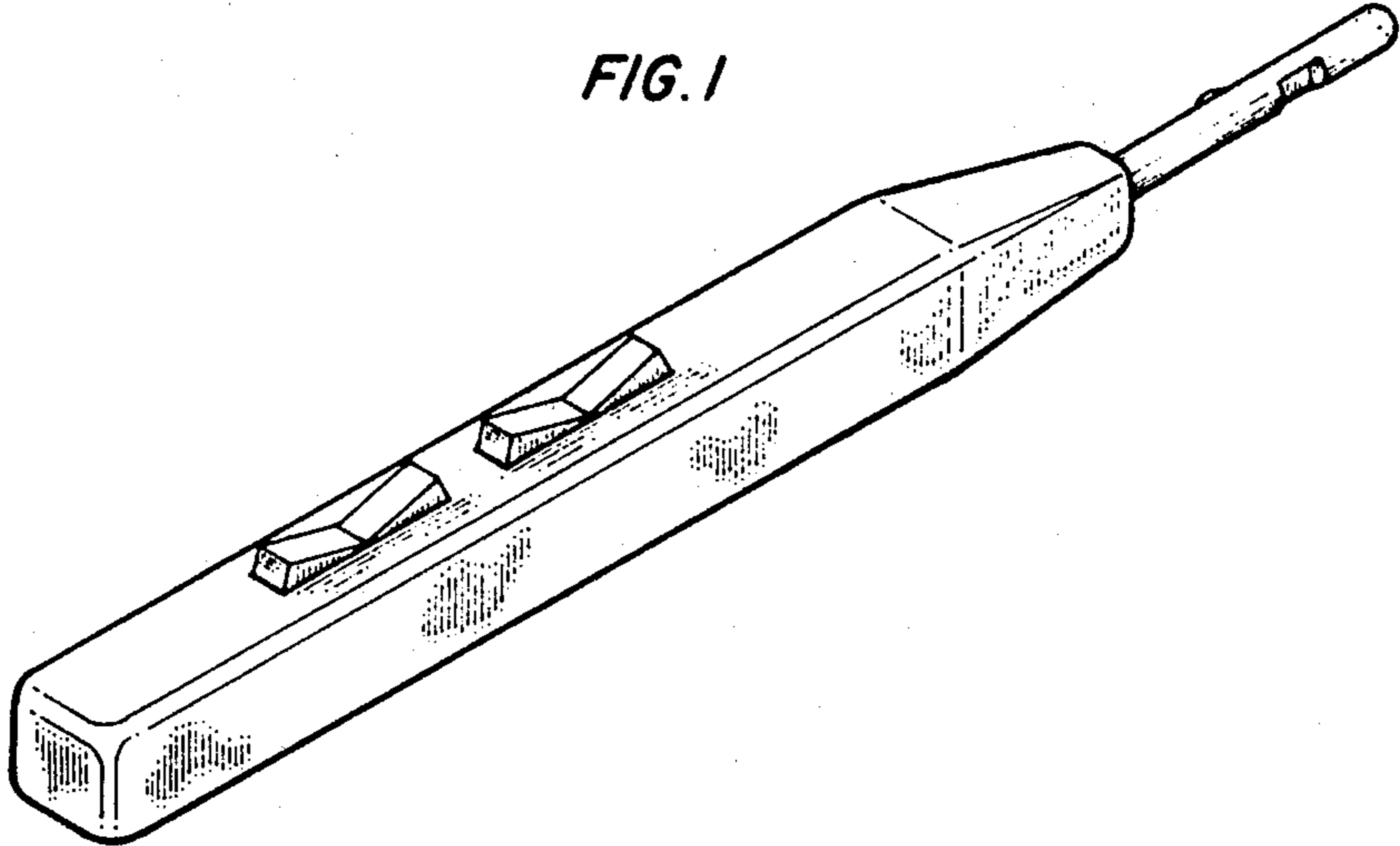

FIG. 2



FIG. 3

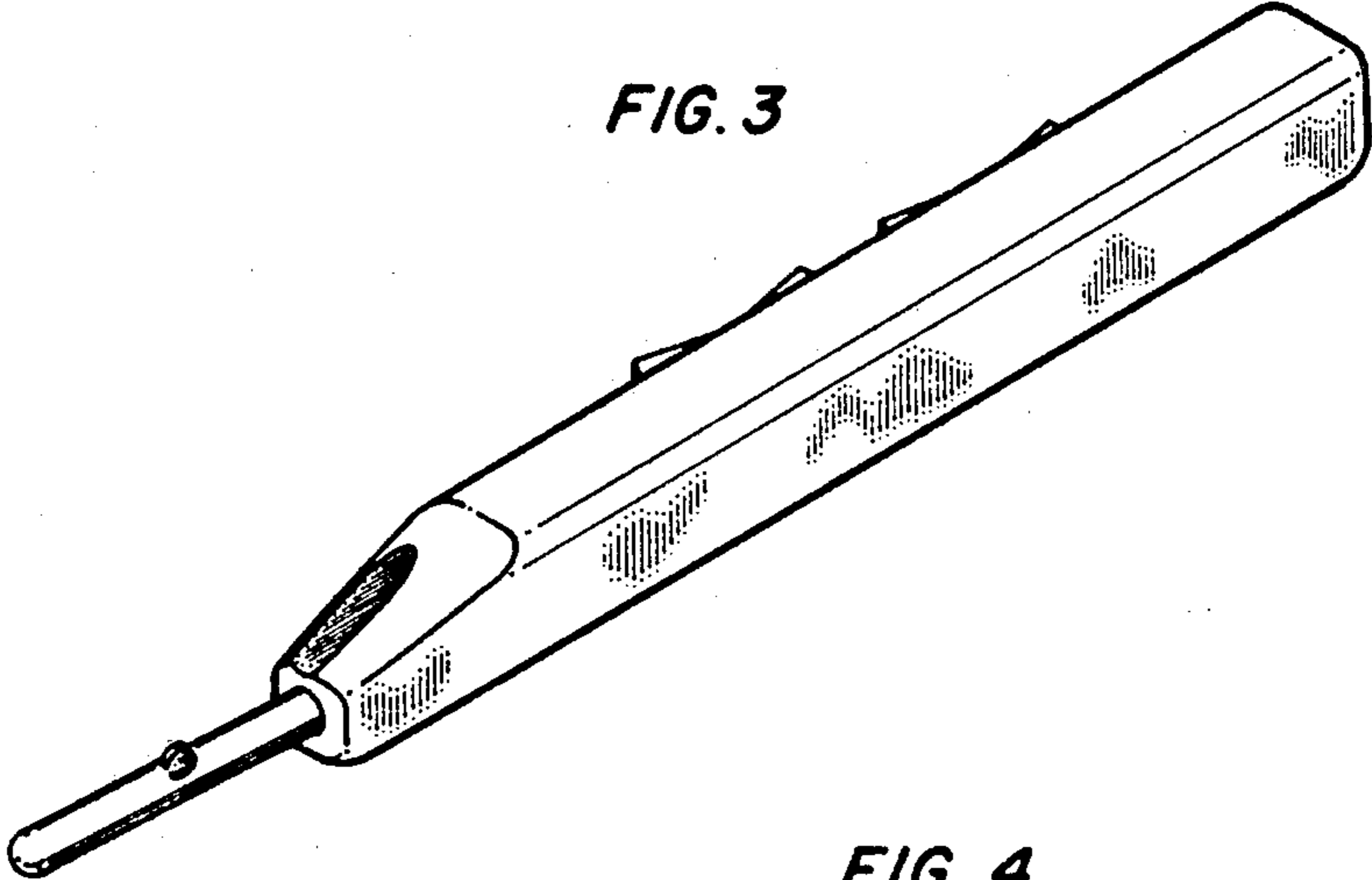

FIG. 4

