

[54] CANOPY

[75] Inventor: Charles M. Baffo, Wilton, Conn.

[73] Assignee: Mobil Oil Corporation, New York, N.Y.

[**] Term: 14 Years

[21] Appl. No.: 413,323

[22] Filed: Aug. 31, 1982

[52] U.S. Cl. D25/56; D25/1; D25/19

[58] Field of Search D25/1, 18, 19, 22, 23, D25/56; 52/66

[56] References Cited

U.S. PATENT DOCUMENTS

D. 194,095	11/1962	Little	D25/23
D. 217,288	4/1970	Noyes	D25/56 X
D. 241,632	9/1976	Noyes	D25/56
2,959,826	11/1960	Larsen et al.	D25/56 X

Primary Examiner—A. Hugo Word
Attorney, Agent, or Firm—Alexander J. McKillop;
Michael G. Gilman; Charles J. Speciale

[57] CLAIM

The ornamental design for a canopy, as described above and shown in the accompanying drawings.

DESCRIPTION

FIG. 1 is a perspective view of a canopy showing my new design;
FIG. 2 is a front elevational view thereof;
FIG. 3 is an elevational view of each side thereof;
FIG. 4 is a cross-sectional view taken along line 4—4 of FIG. 2 with the lower portion of the canopy support being cut away; and
FIG. 5 is a top plan view thereof.

The broken line disclosure of a gasoline pump in FIG. 1 is for illustrative purposes only to show that a gasoline pump may be positioned between one or more pairs of vertical columns, and forms no part of the claimed design.

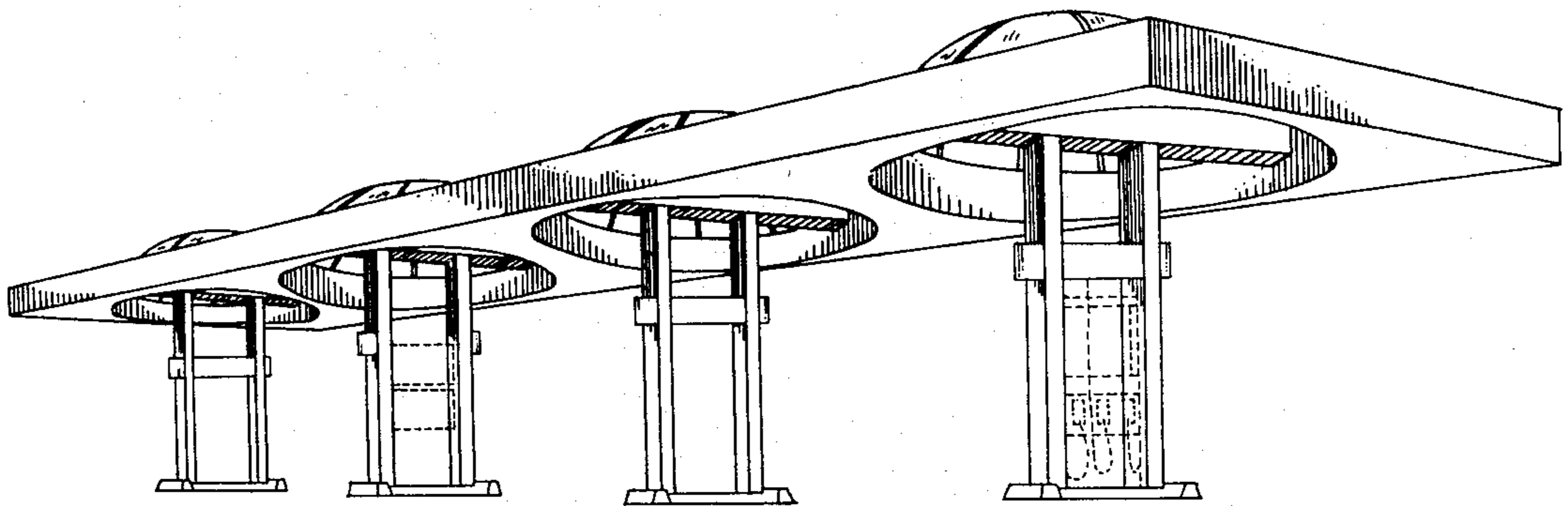

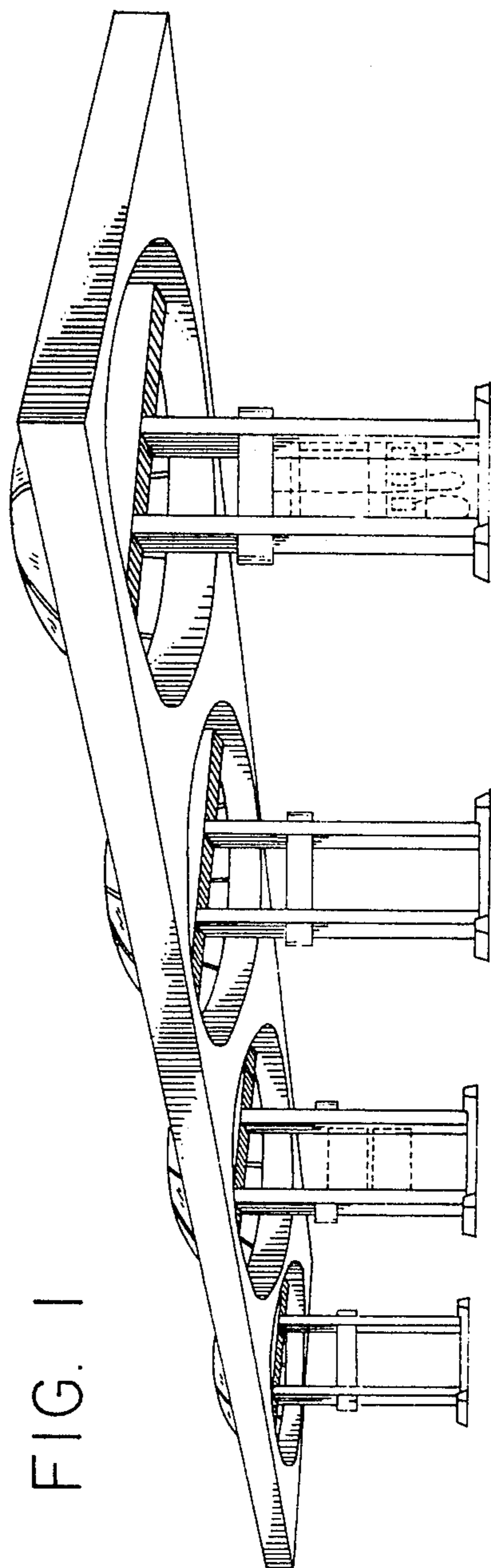

FIG. 1

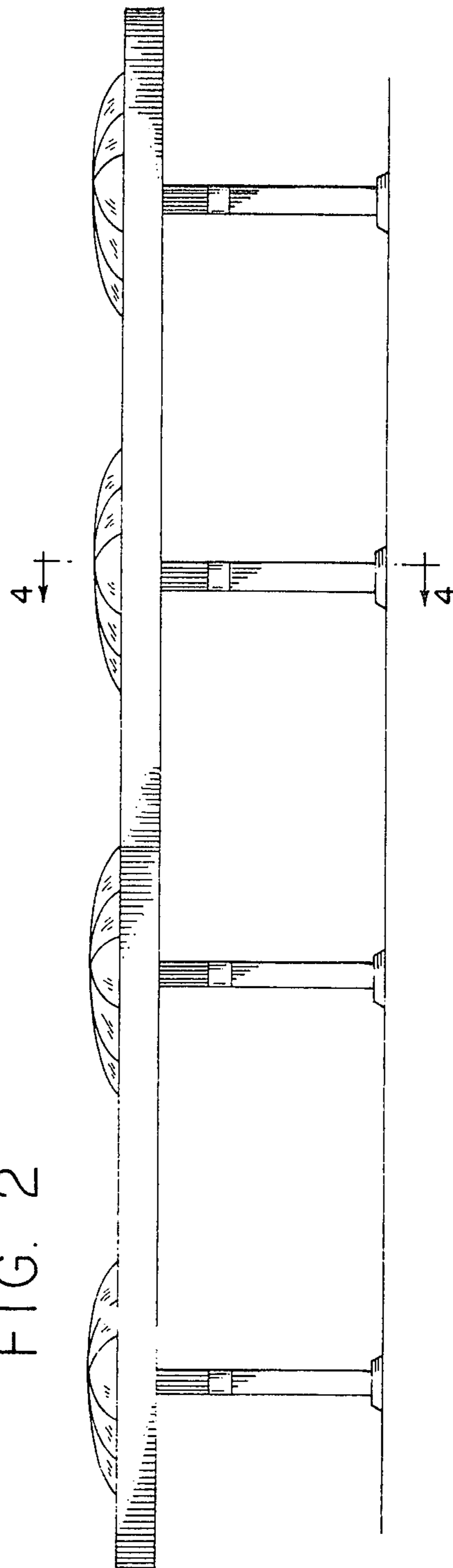

FIG. 2

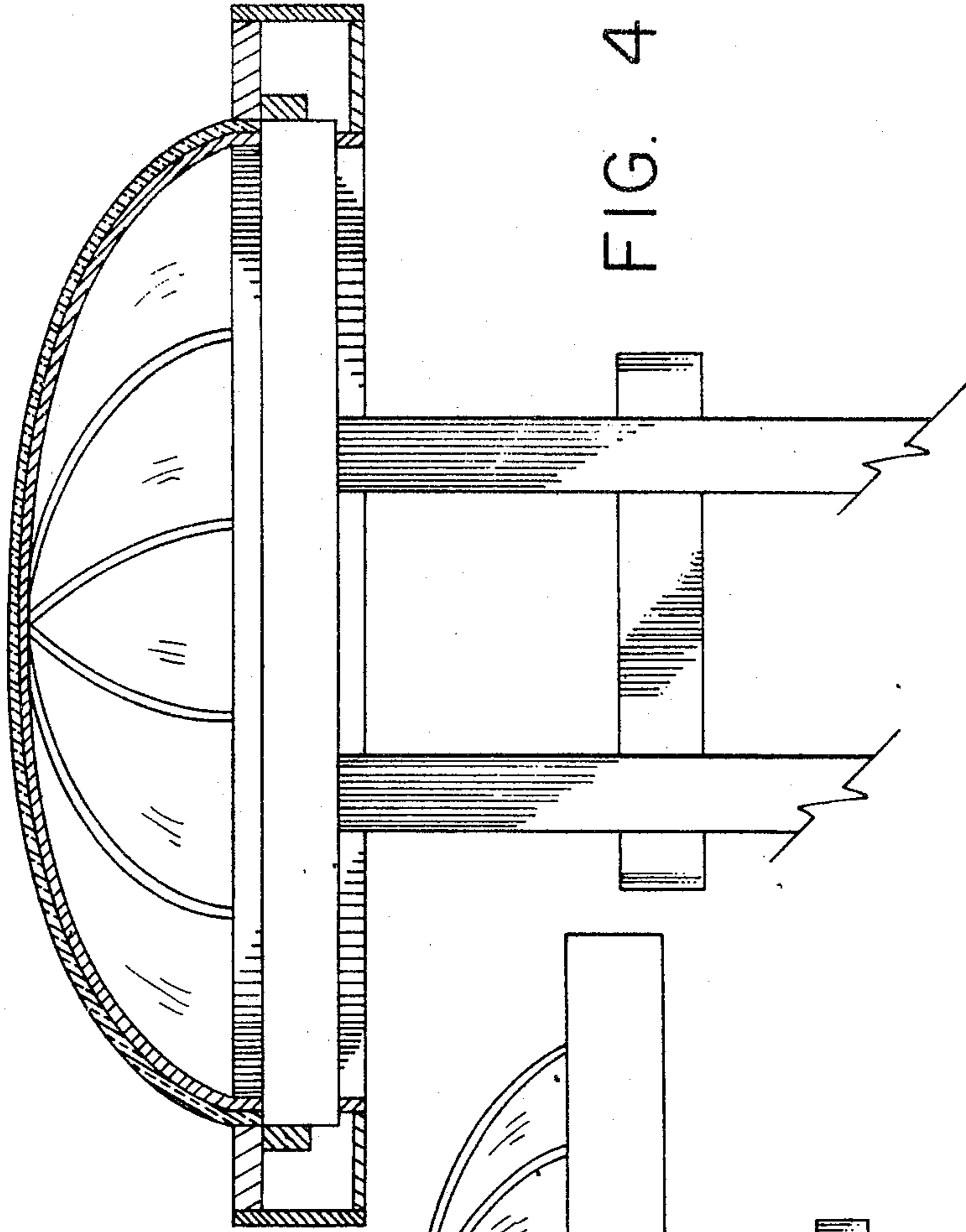

FIG. 4

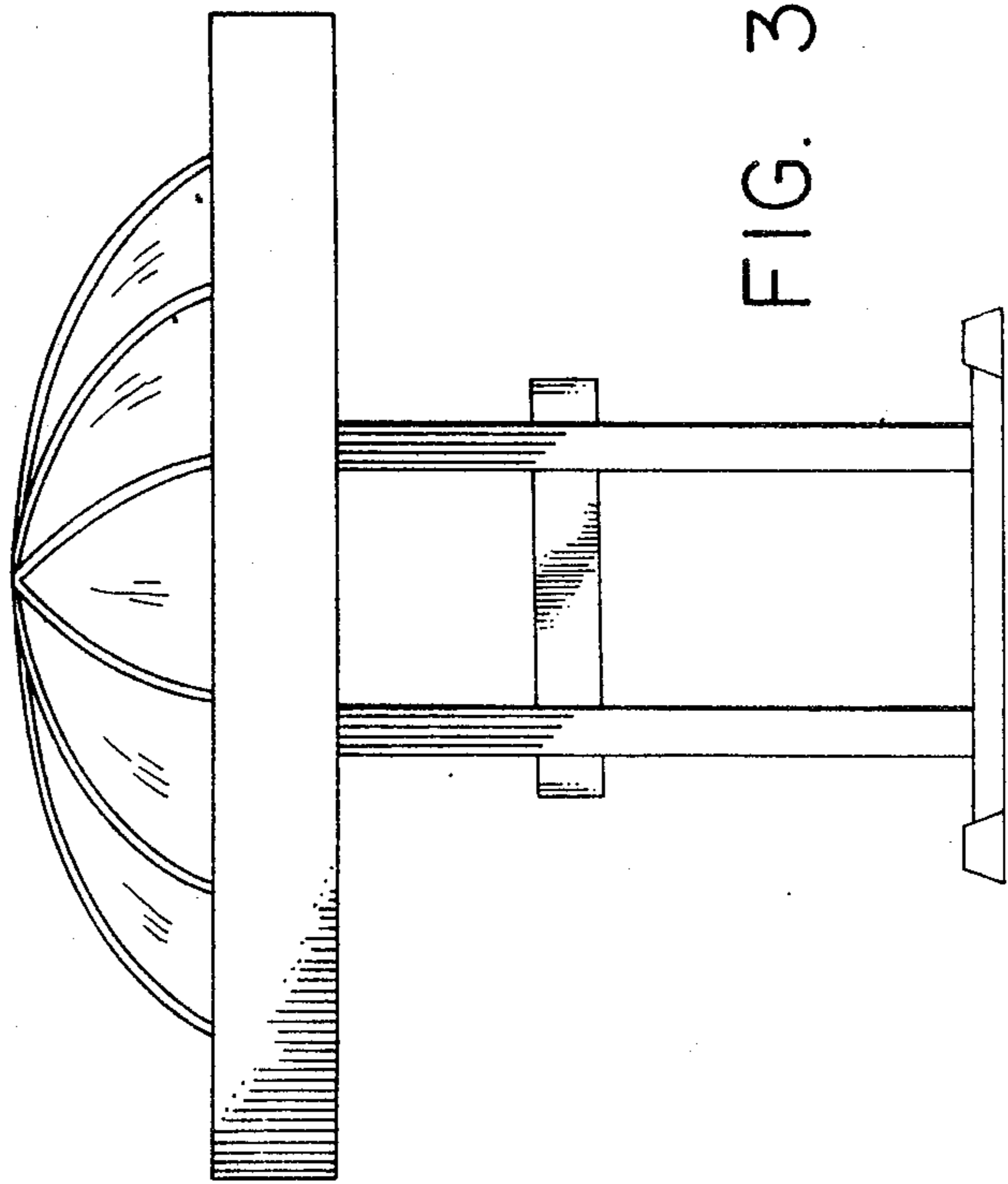

FIG. 3

FIG. 5

