

[54] COMBINED MOTOR VEHICULAR CASSETTE PLAYER AND RADIO

[75] Inventor: Hiroshi Yoshida, Tokyo, Japan

[73] Assignee: Clarion Corporation, Tokyo, Japan

[**] Term: 14 Years

[21] Appl. No.: 343,299

[22] Filed: Jan. 27, 1982

[52] U.S. Cl. D14/5; D14/7; D14/68; D14/72

[58] Field of Search D14/1, 5-7, D14/68, 70-76, 95, 99

[56] References Cited

U.S. PATENT DOCUMENTS

D. 261,136 10/1981 Yamada et al. D14/5

OTHER PUBLICATIONS

Best Products '80 Buyer's Bk., ©'79, p. 325, Item "K", Emerson M-2660 Model.

Primary Examiner—Jane E. Corrigan
Attorney, Agent, or Firm—George B. Oujevolk

[57] CLAIM

The ornamental design for a combined motor vehicular cassette player and radio, substantially as shown.

DESCRIPTION

FIG. 1 is a front, top and right side perspective view of a combined motor vehicular cassette player and radio showing my new design;
FIG. 2 is a front elevational view;
FIG. 3 is a rear elevational view;
FIG. 4 is a left side elevational view;
FIG. 5 is a right side elevational view;
FIG. 6 is a top plan view; and
FIG. 7 is a bottom plan view.

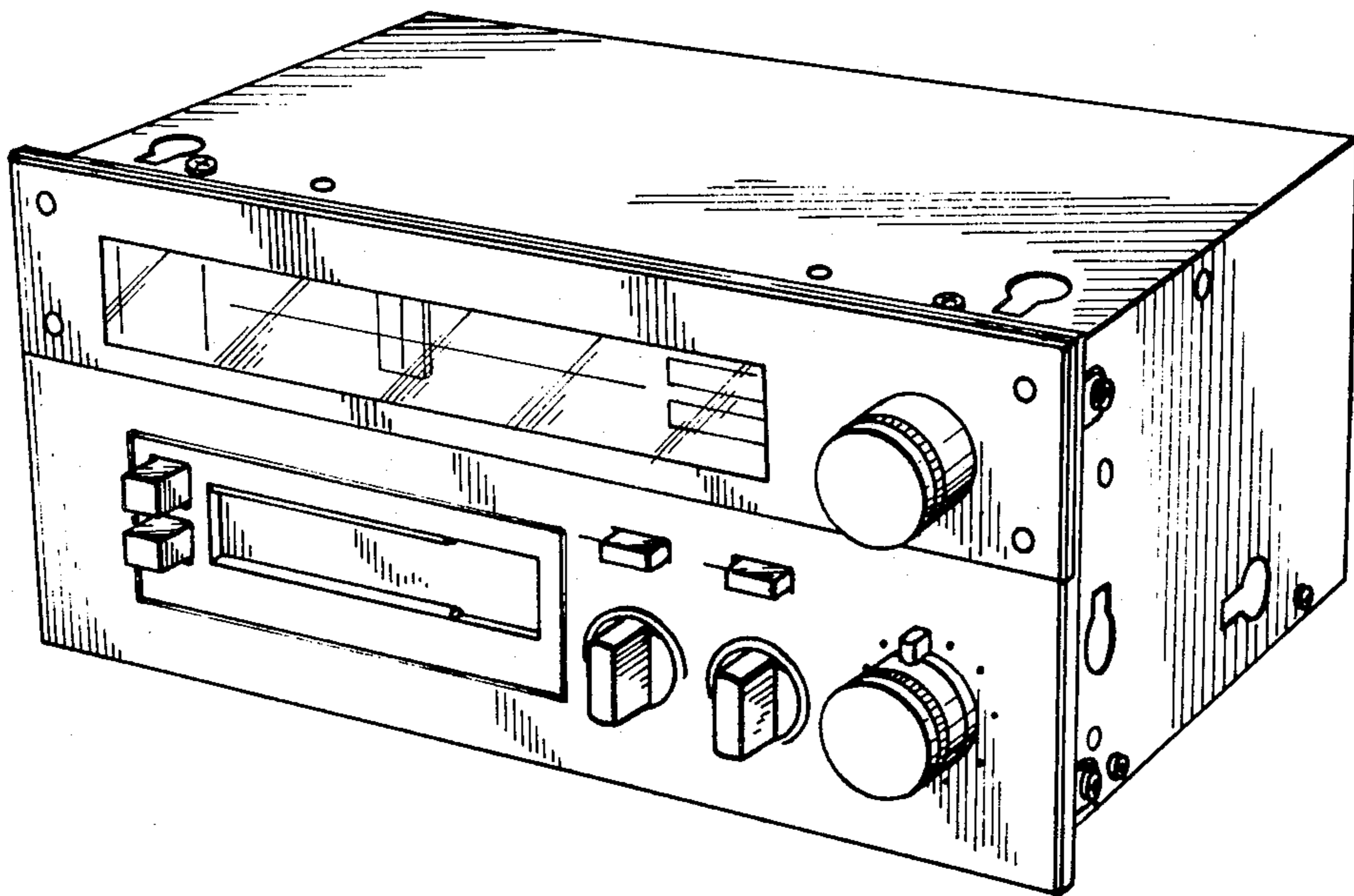

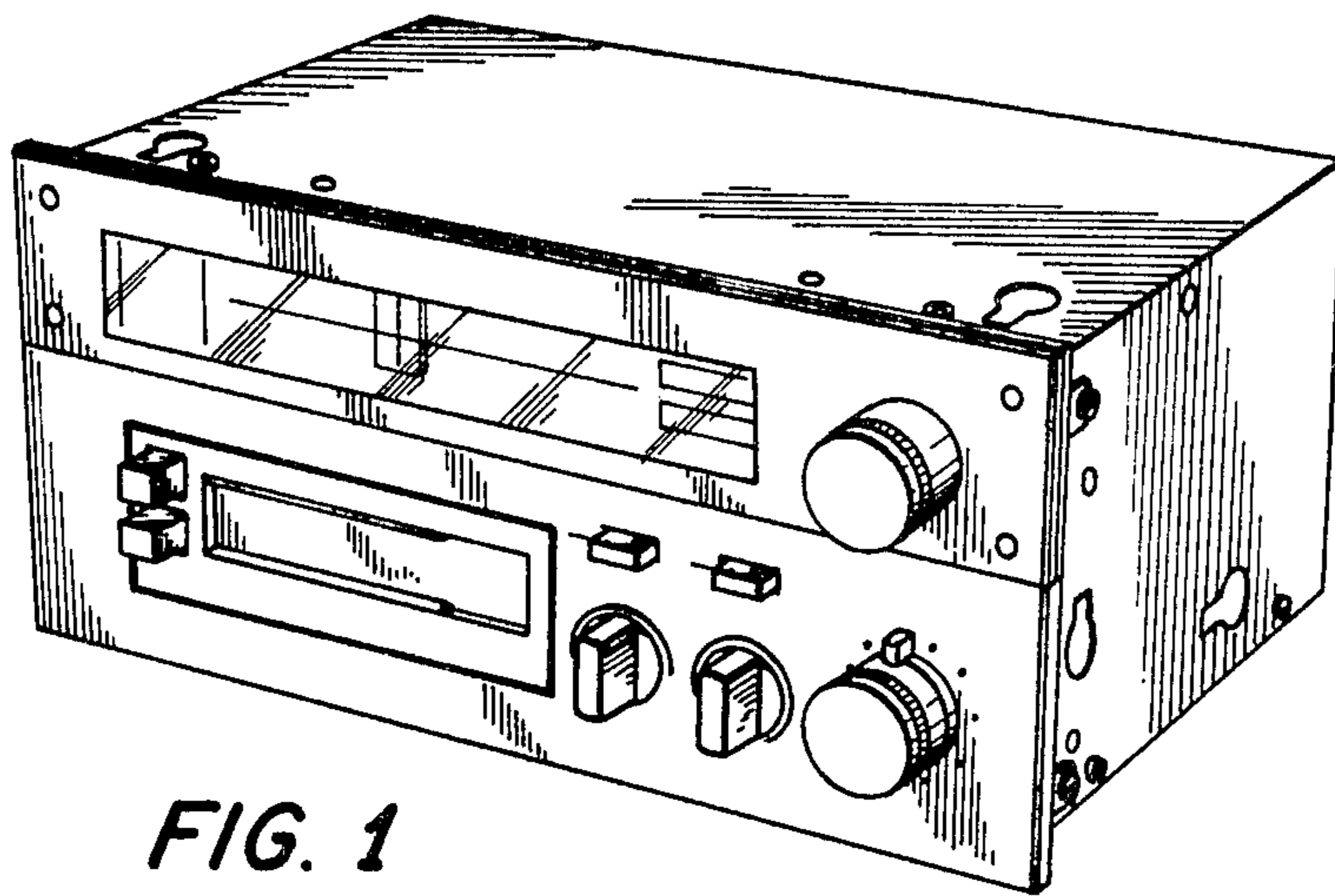

FIG. 1

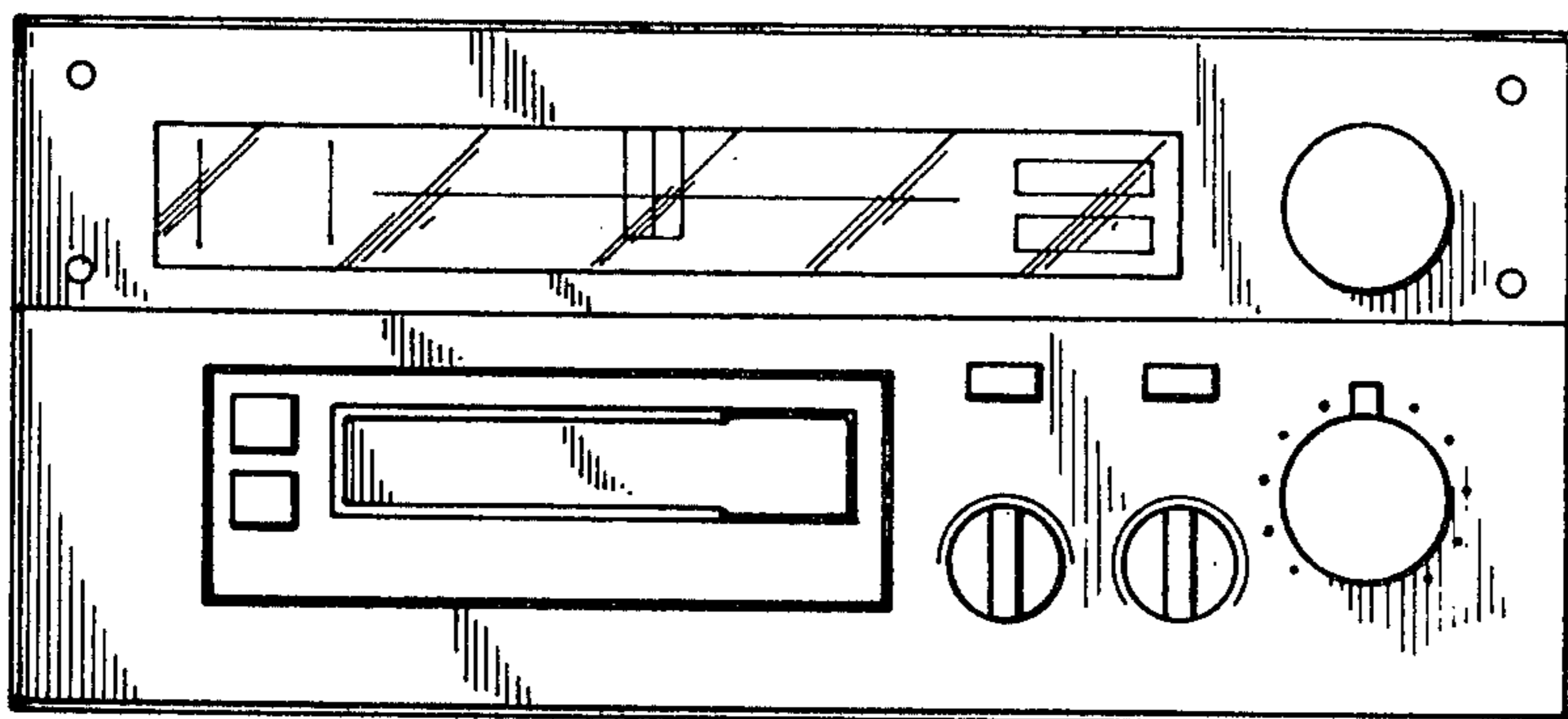

FIG. 2

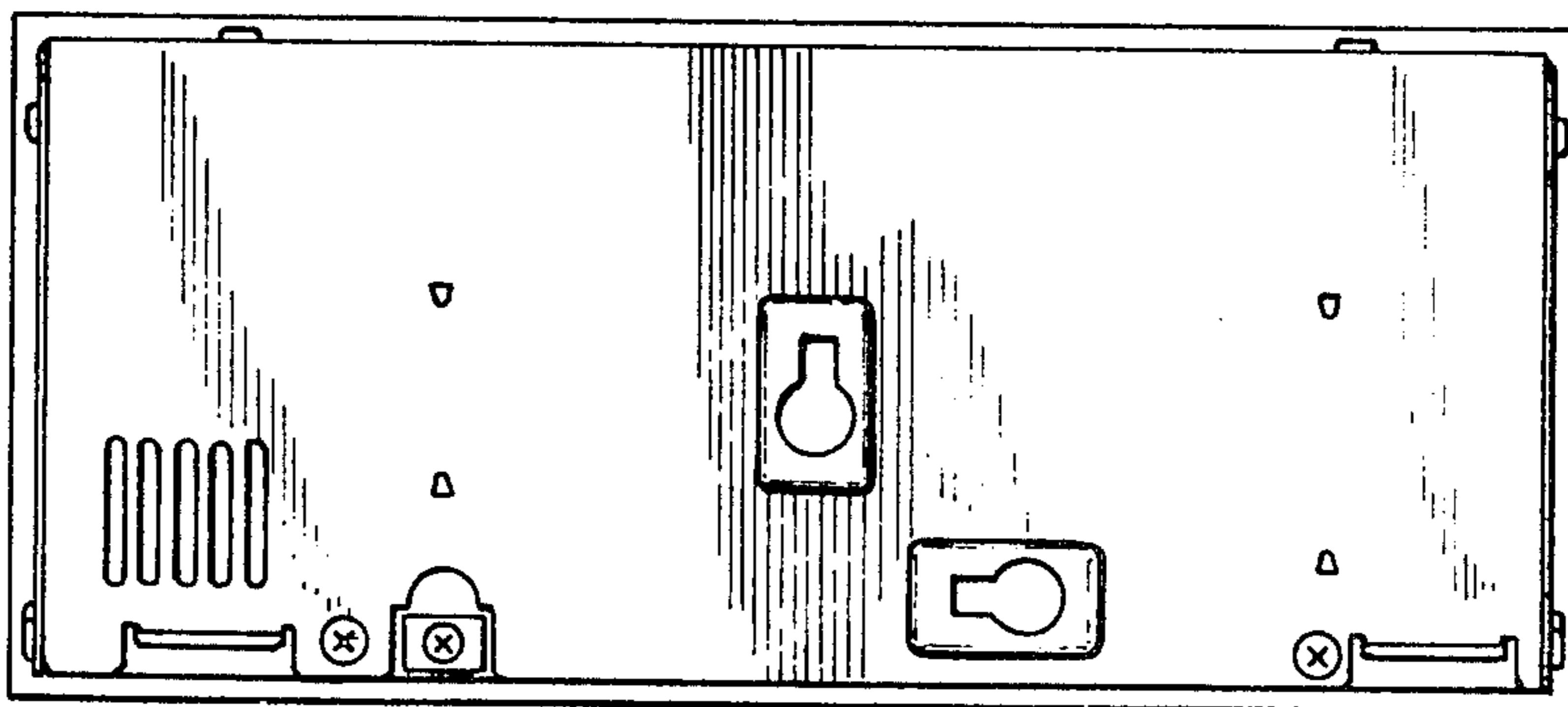

FIG. 3

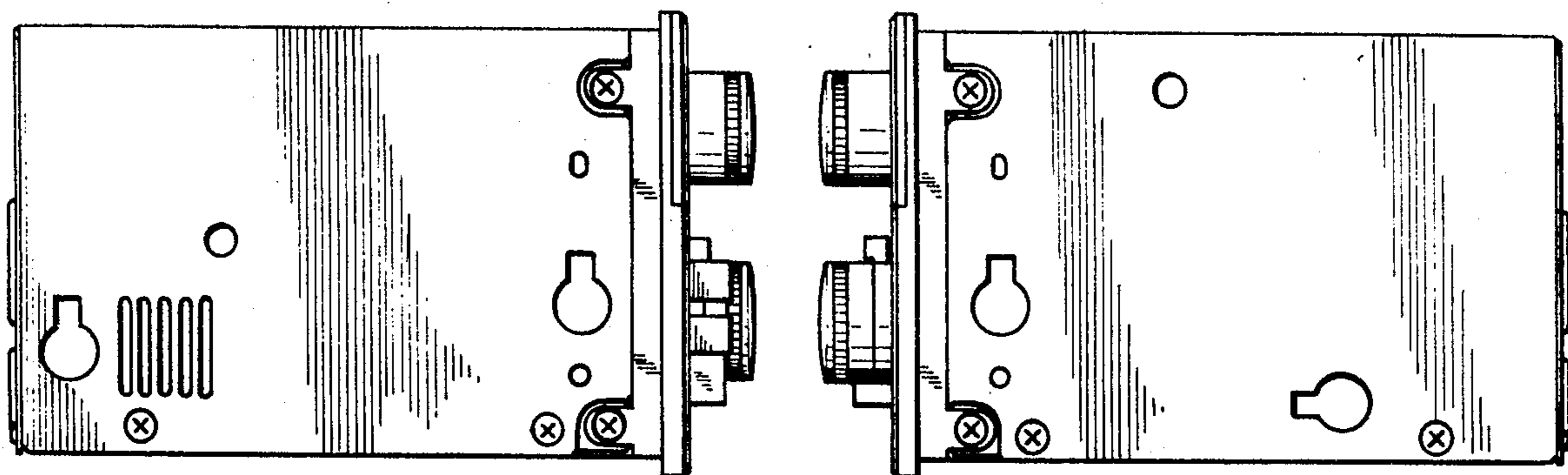

FIG. 4

FIG. 5

FIG. 6

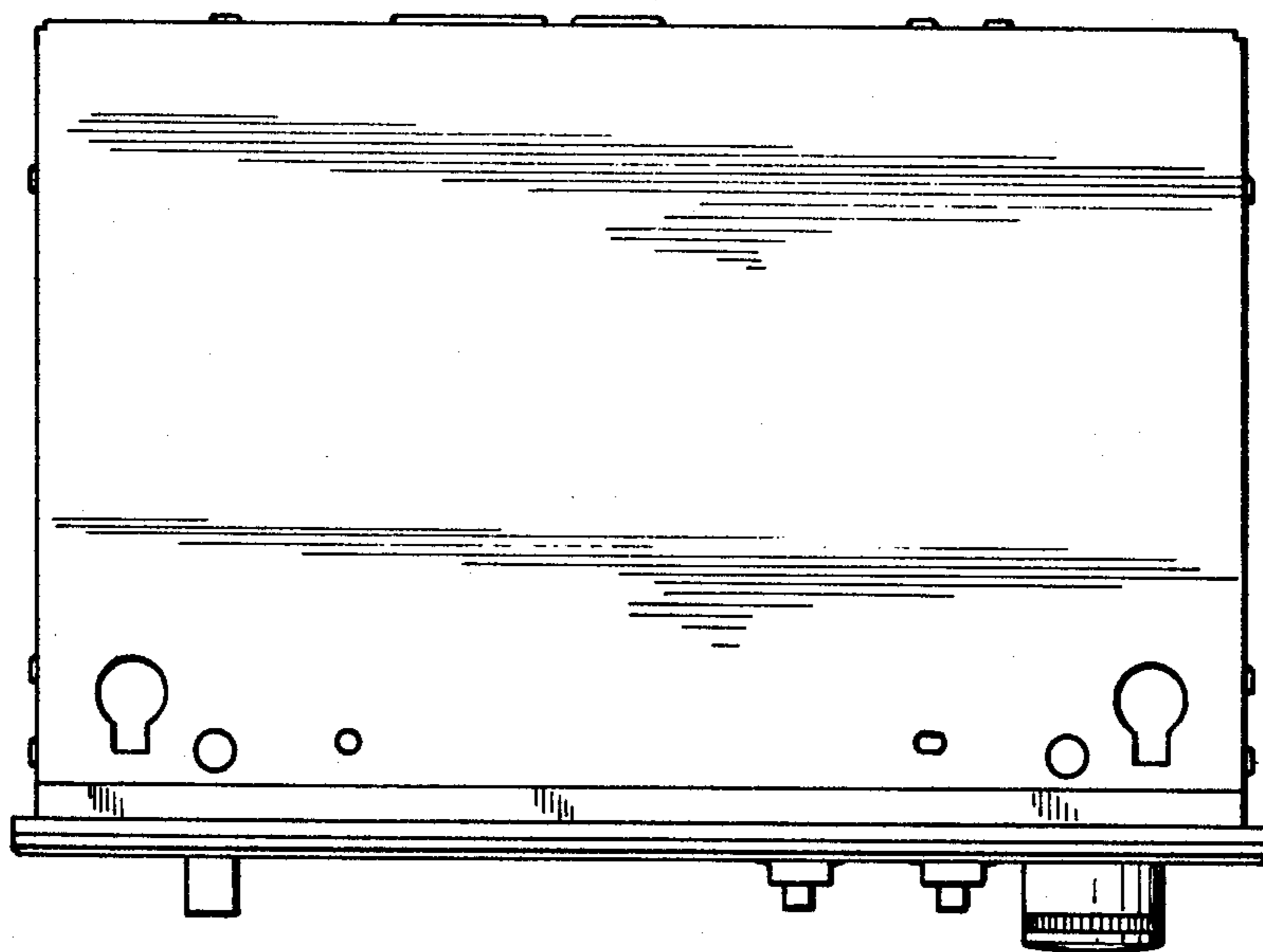

FIG. 7

