

# United States Patent [19]

Heiman et al.

[11] Patent Number: **Des. 276,331**

[45] Date of Patent: **\*\* Nov. 13, 1984**

[54] **MOTORCYCLE LUGGAGE RACK**

[75] Inventors: **John A. Heiman, Waukesha, Wis.;**  
**Walter J. Murzin, Taylor, Mich.**

[73] Assignee: **Harley-Davidson Motor Co., Inc.,**  
**Milwaukee, Wis.**

[\*\*] Term: **14 Years**

[21] Appl. No.: **389,020**

[22] Filed: **Jun. 16, 1982**

[52] U.S. Cl. .... **D12/158**

[58] Field of Search ..... **D12/158; 224/32 A, 39,**  
**224/30 R**

[56]

## References Cited

### U.S. PATENT DOCUMENTS

D. 271,389 11/1983 Turkington et al. .... D12/158

### OTHER PUBLICATIONS

Cycles Inc. Parts & Accessories Catalog, p. 9, Cycle  
Rax, upper left side of page.

*Primary Examiner*—James M. Gandy

[57]

## CLAIM

The ornamental design for a motorcycle luggage rack,  
as shown.

## DESCRIPTION

FIG. 1 is a top plan view of a motorcycle luggage rack  
showing our new design;

FIG. 2 is a side elevation view thereof;

FIG. 3 is a front elevation view thereof;

FIG. 4 is a rear elevation view thereof; and,

FIG. 5 is a bottom plan view thereof.

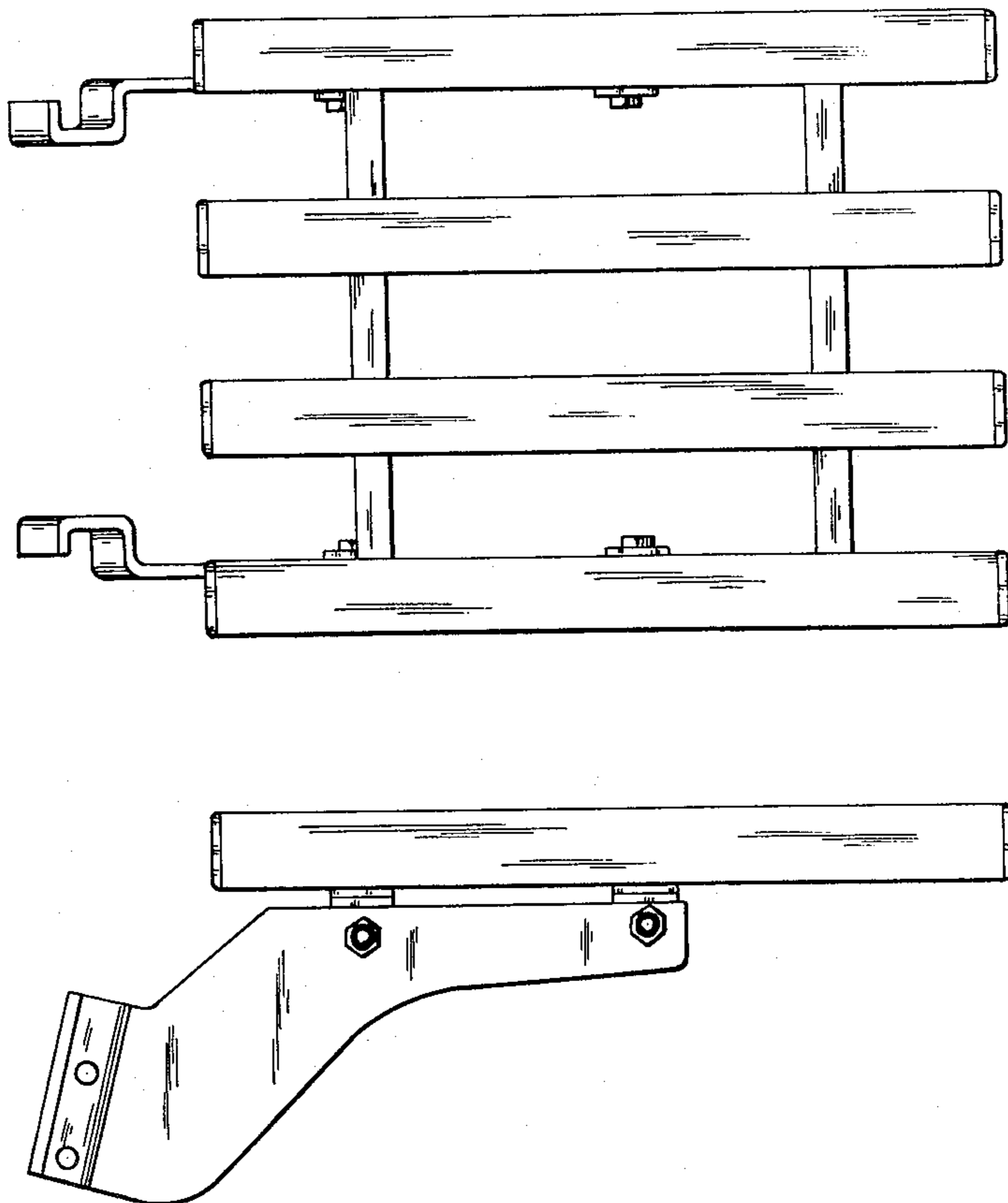

FIG.1

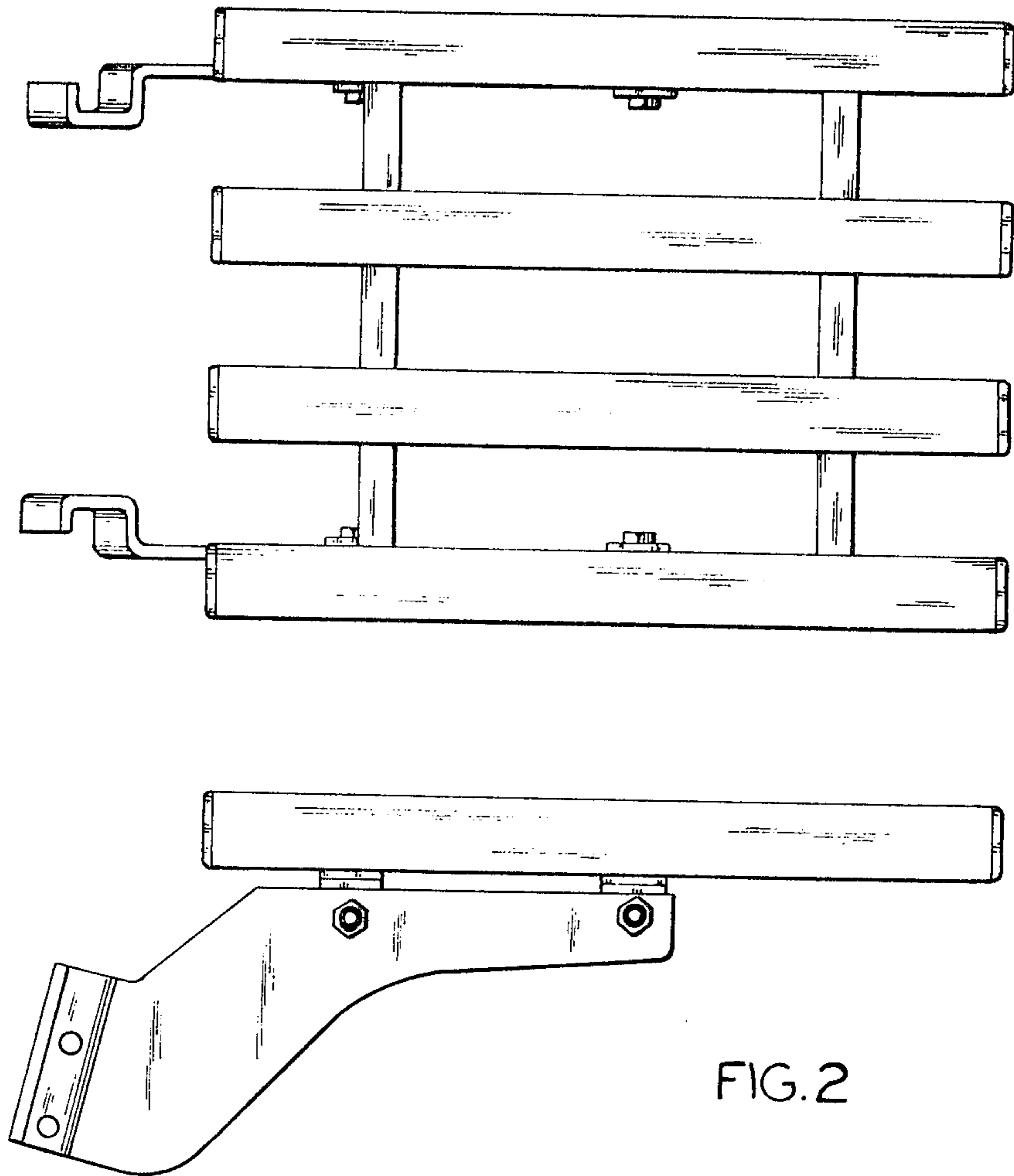

FIG.2

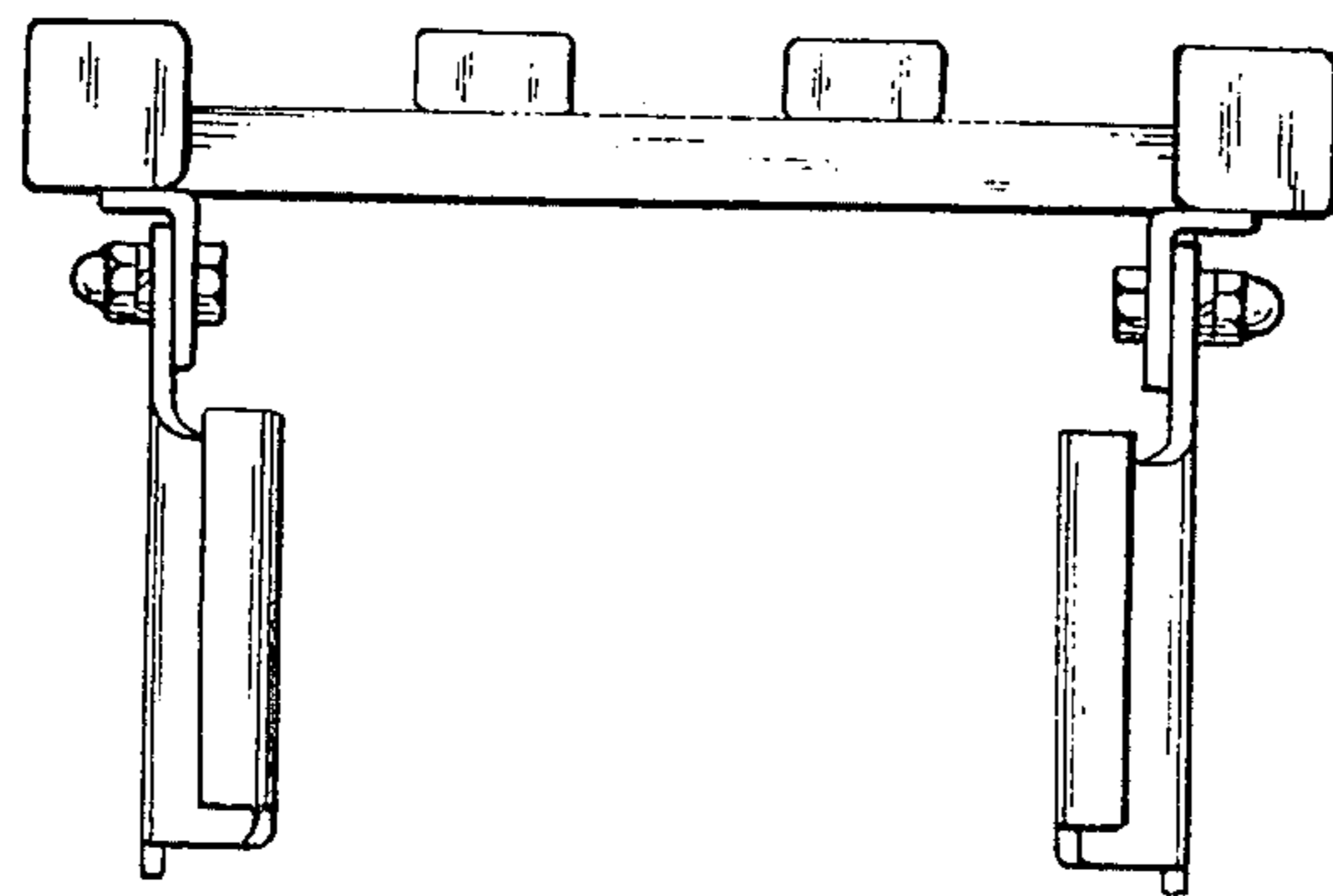

FIG.3

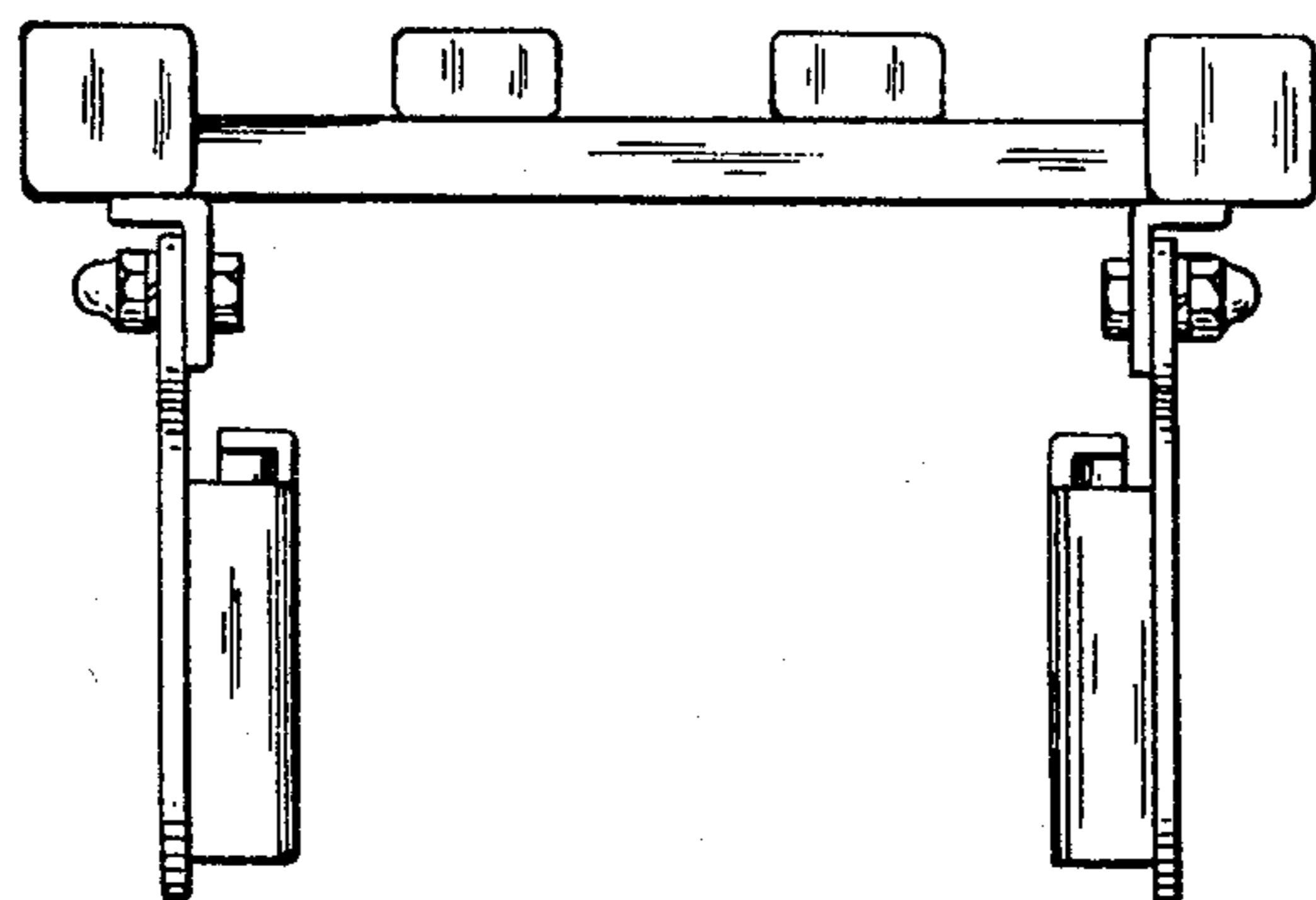

FIG. 4

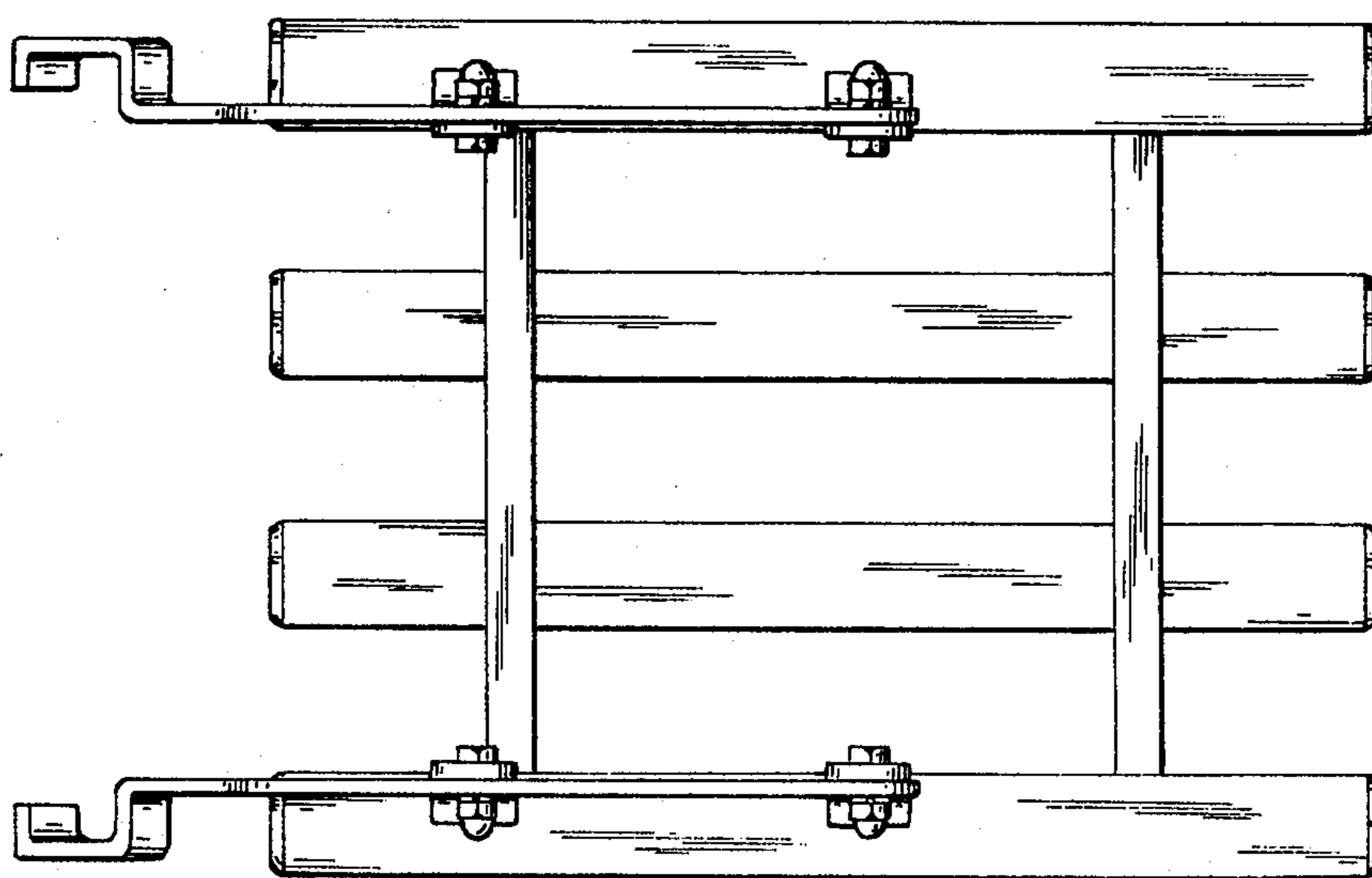

FIG. 5