

[54] **LOAD BODY**

[75] Inventor: **George G. Bell, Jr., Jackson, Miss.**
[73] Assignee: **Un-Common Carrier Corp., Jackson, Miss.**
[**] Term: **14 Years**
[21] Appl. No.: **320,195**
[22] Filed: **Nov. 6, 1981**
[52] U.S. Cl. **D12/96; D12/102**
[58] Field of Search **D12/96, 102; 280/63; 296/181, 183**

[56] **References Cited**
U.S. PATENT DOCUMENTS

D. 224,398 7/1972 Baugh et al. D12/102
D. 256,114 7/1980 Bell, Jr. D12/102

FOREIGN PATENT DOCUMENTS

1353575 1/1964 France 296/168

Primary Examiner—James M. Gandy
Attorney, Agent, or Firm—Harvey B. Jacobson

[57] **CLAIM**

The ornamental design for a load body, as shown and described.

DESCRIPTION

FIG. 1 is a perspective view of the load body with all of the gull wing doors in their open position showing my new design;
FIG. 2 is a top plan view thereof;
FIG. 3 is a side elevational view thereof the opposite side being substantially a mirror image of that shown;
FIG. 4 is a rear end elevational view thereof; and
FIG. 5 is a front end elevational view thereof.

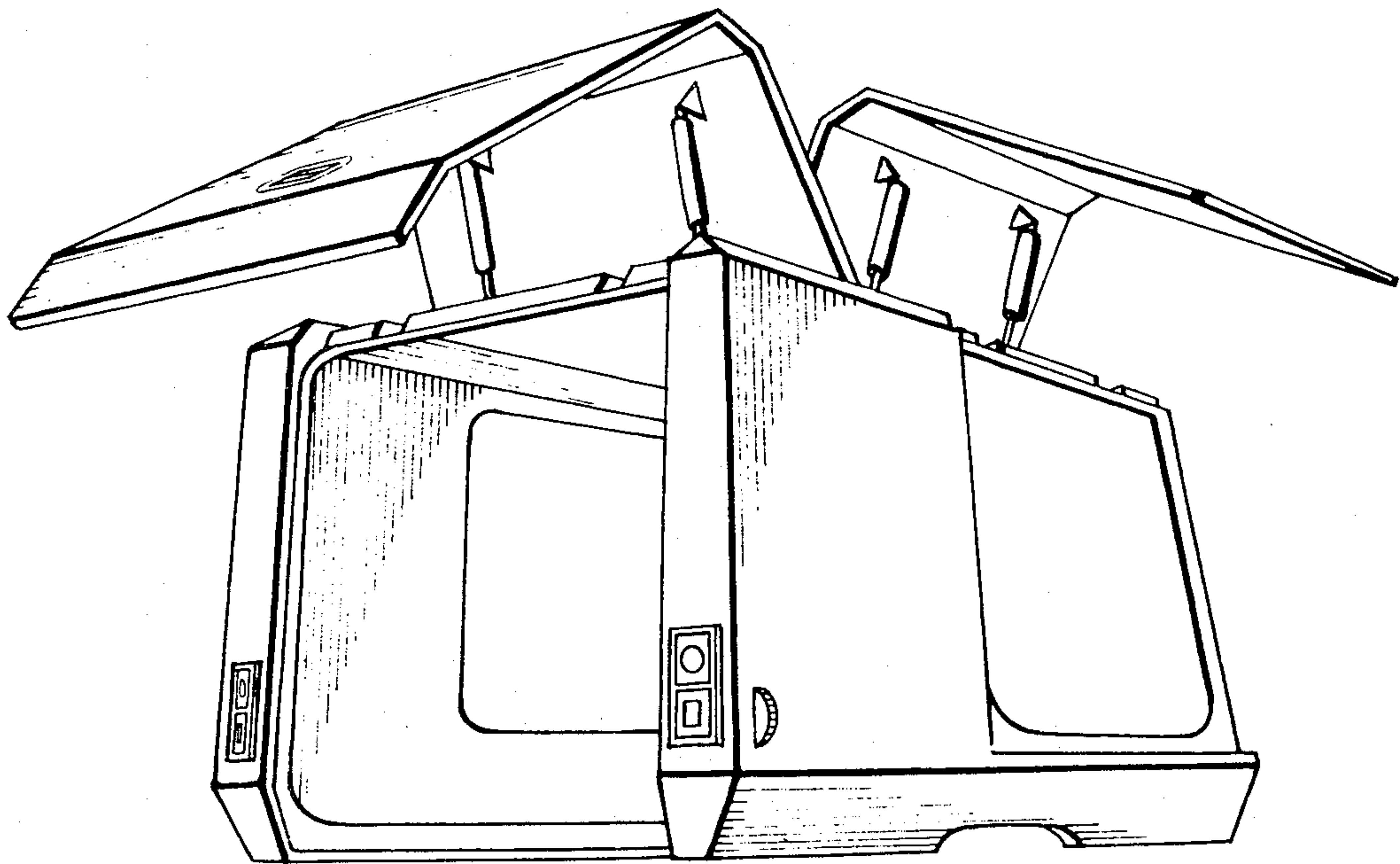

FIG. 1

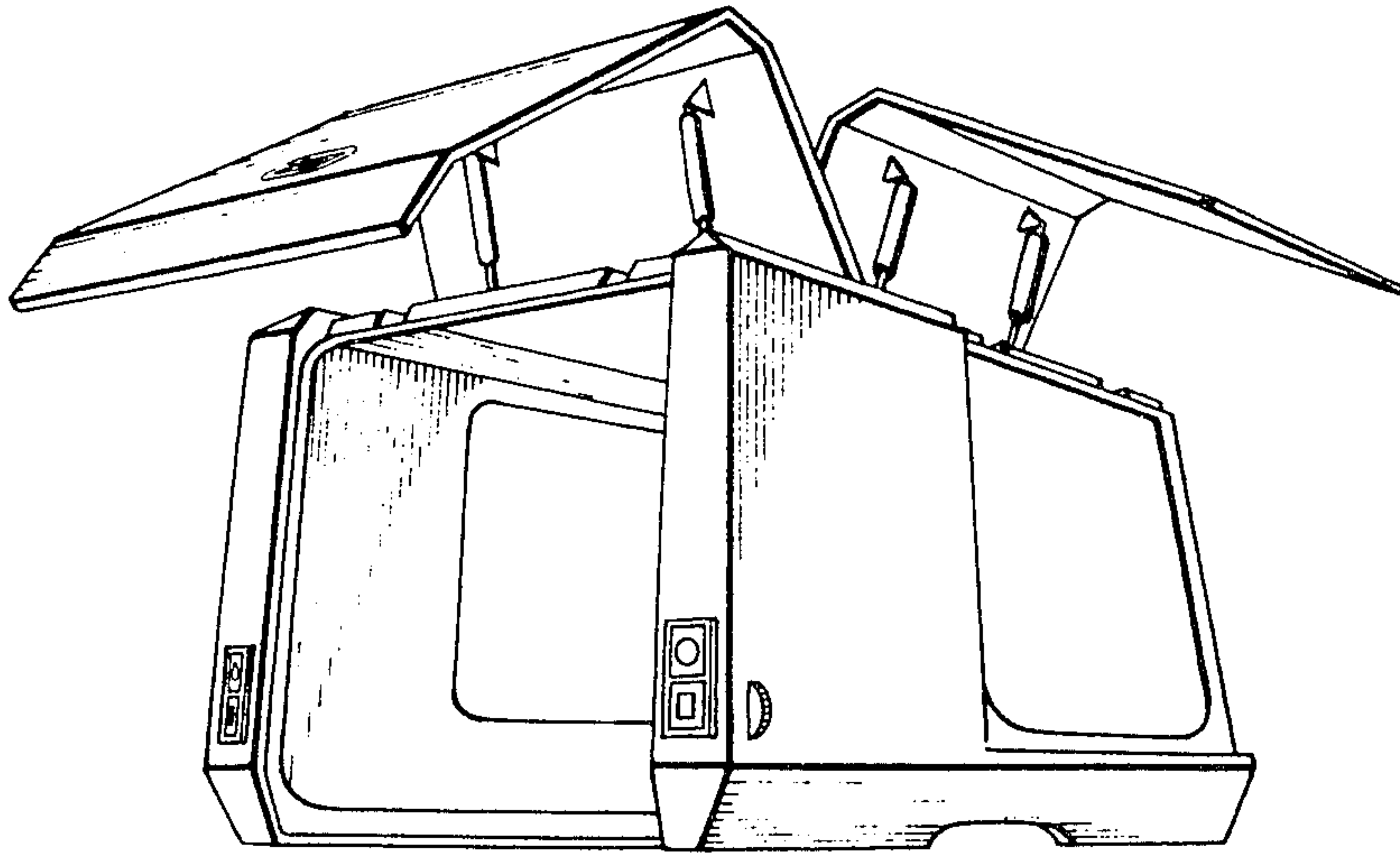

FIG. 2

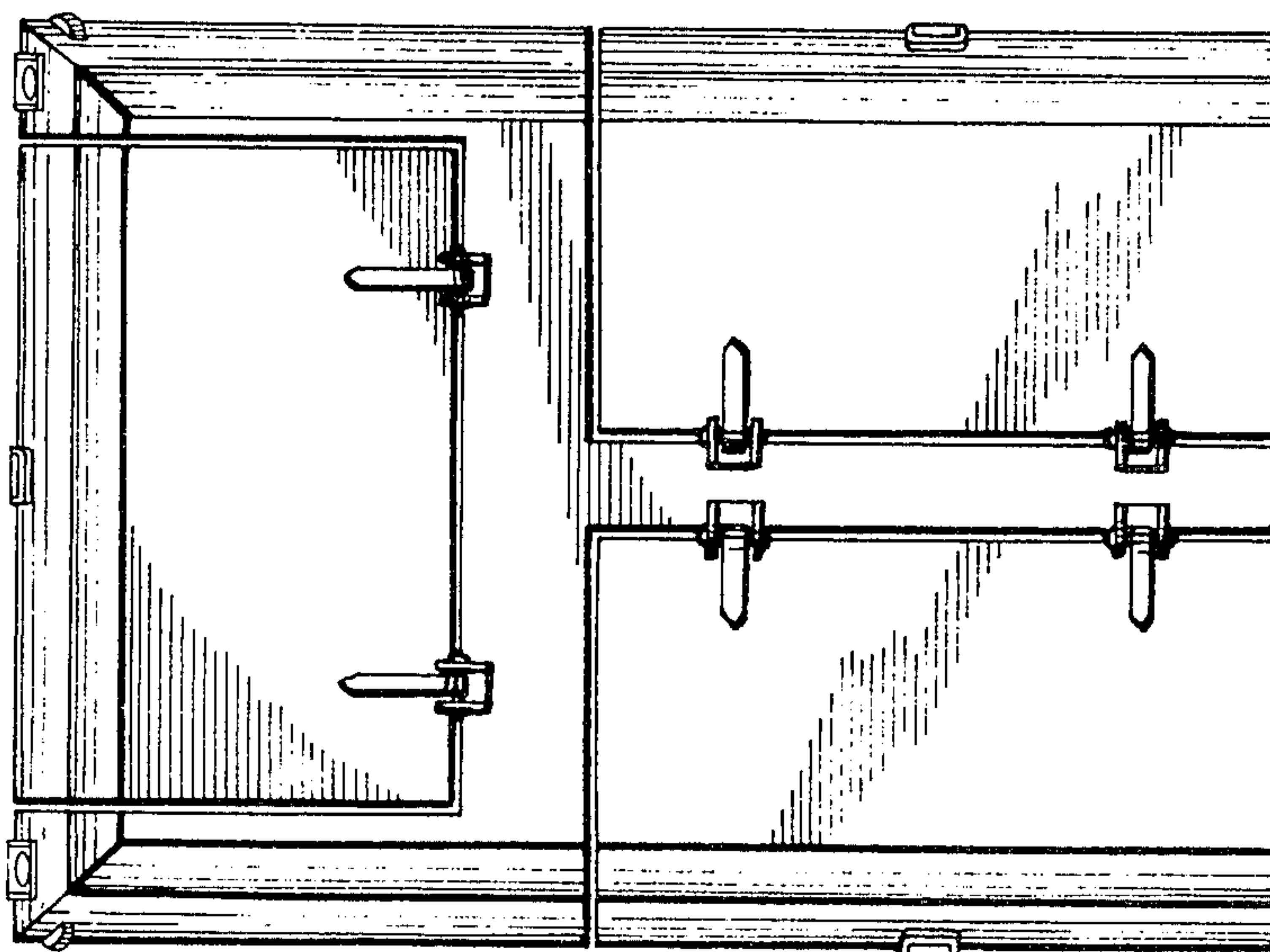

FIG. 3

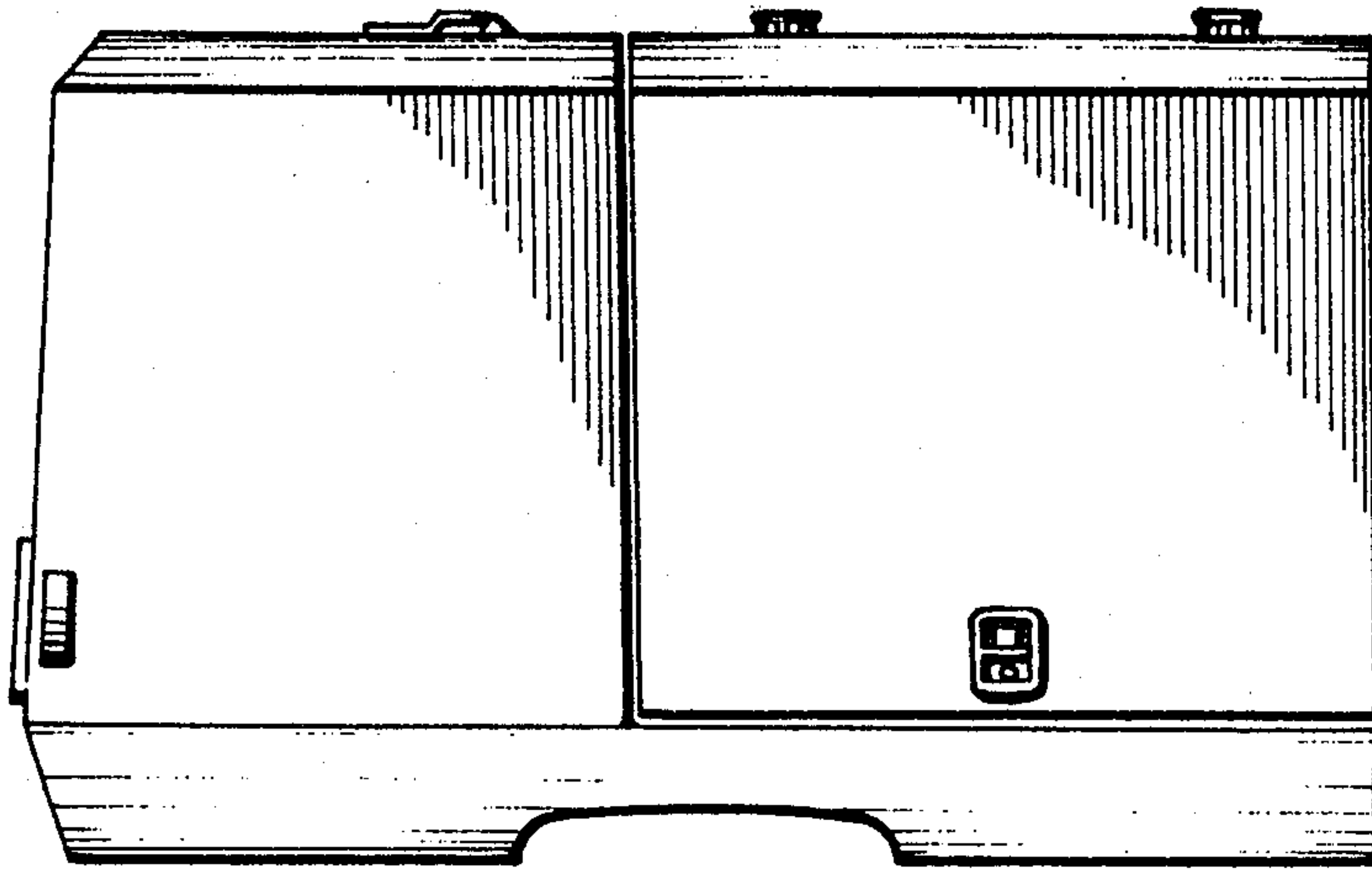

FIG. 4

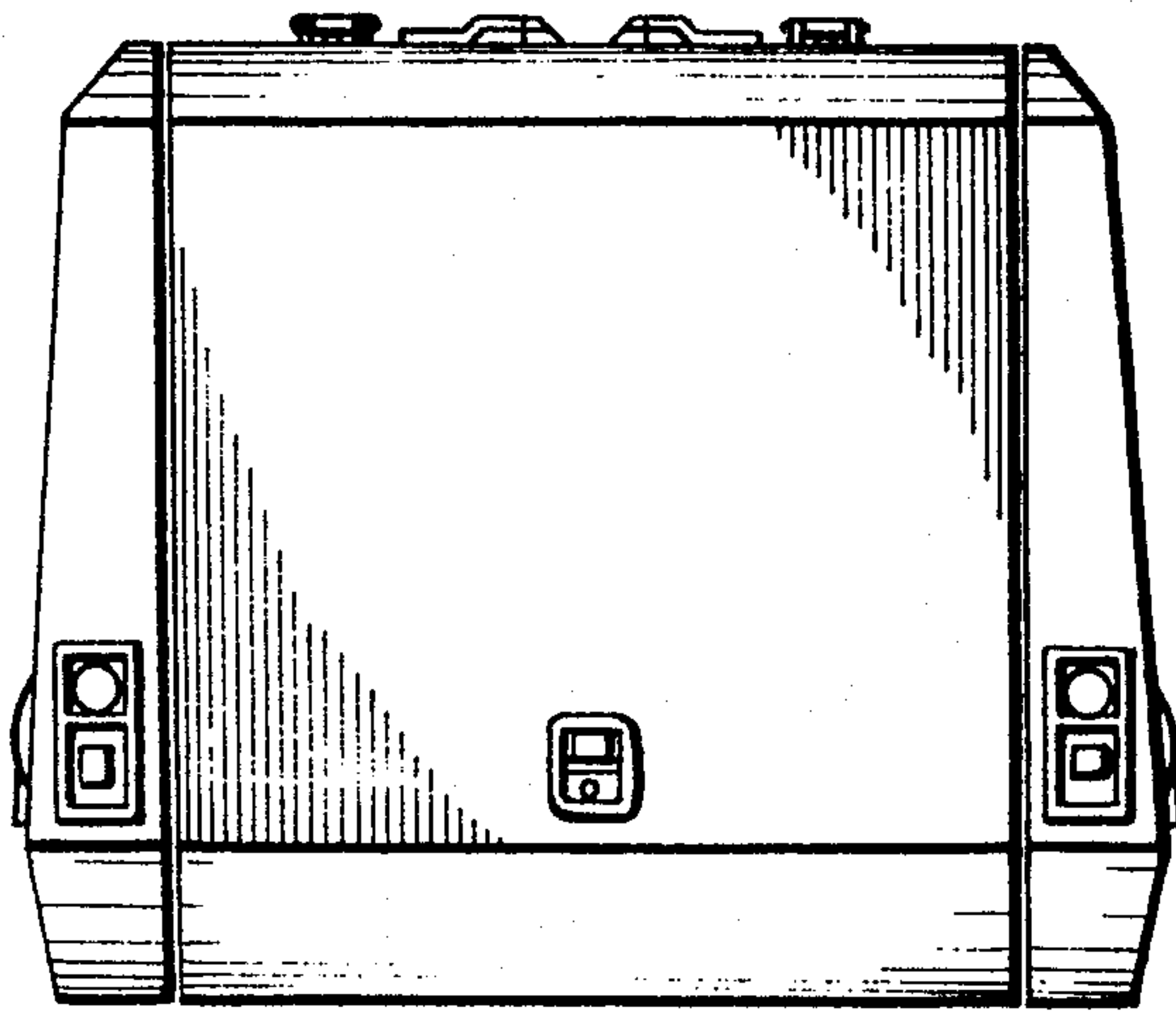

FIG. 5

