

[54] LUG PAIR UNIT FOR A PIPE CLAMP

[76] Inventor: James C. Morriss Jr., 140 Northwood, Nash, Tex. 75569

[**] Term: 14 Years

[21] Appl. No.: 352,942

[22] Filed: Feb. 26, 1982

[52] U.S. Cl. D8/396; D8/394

[58] Field of Search D8/382, 394, 395, 396; 24/20 R, 20 EE, 20 LS, 23 EE, 279; 285/420; 248/65, 68.1, 74.1, 74.3, 74.4

[56] References Cited

U.S. PATENT DOCUMENTS

2,853,762	9/1958	Smith	24/279
3,209,427	10/1965	Smith et al.	24/279
3,341,232	9/1967	Deakins	24/279
3,472,537	10/1969	Paterson	285/420
4,409,708	10/1983	Hauffe	24/279
4,413,388	11/1983	Akhtar-Khavari	24/279

FOREIGN PATENT DOCUMENTS

2103698 2/1983 United Kingdom 285/420

Primary Examiner—B. J. Bullock
Attorney, Agent, or Firm—Owen, Wickersham & Erickson

[57] CLAIM

The ornamental design for a lug pair unit for a pipe clamp, substantially as shown.

DESCRIPTION

FIG. 1 is a top plan view of a lug pair unit for a pipe clamp embodying my new design; the threaded portion of the bolt being shown broken away to indicate indeterminate length;

FIG. 2 is a front elevational view thereof, the portion of the attached band being shown in broken lines for illustrative purposes only;

FIG. 3 is a rear elevational view thereof;

FIG. 4 is a side elevational view taken from the right of FIG. 2;

FIG. 5 is a side elevational view taken from the left of FIG. 2;

FIG. 6 is a bottom plan view thereof.

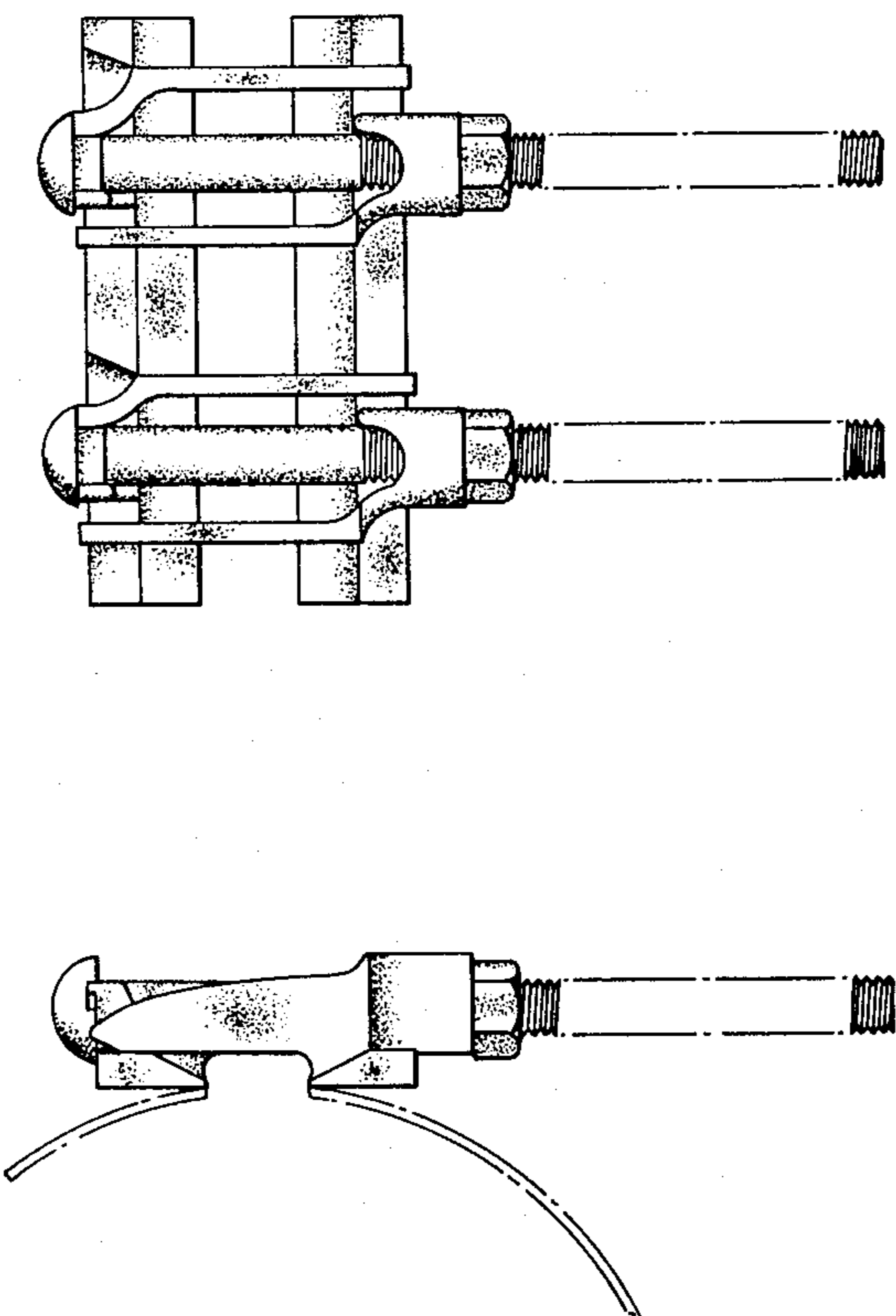

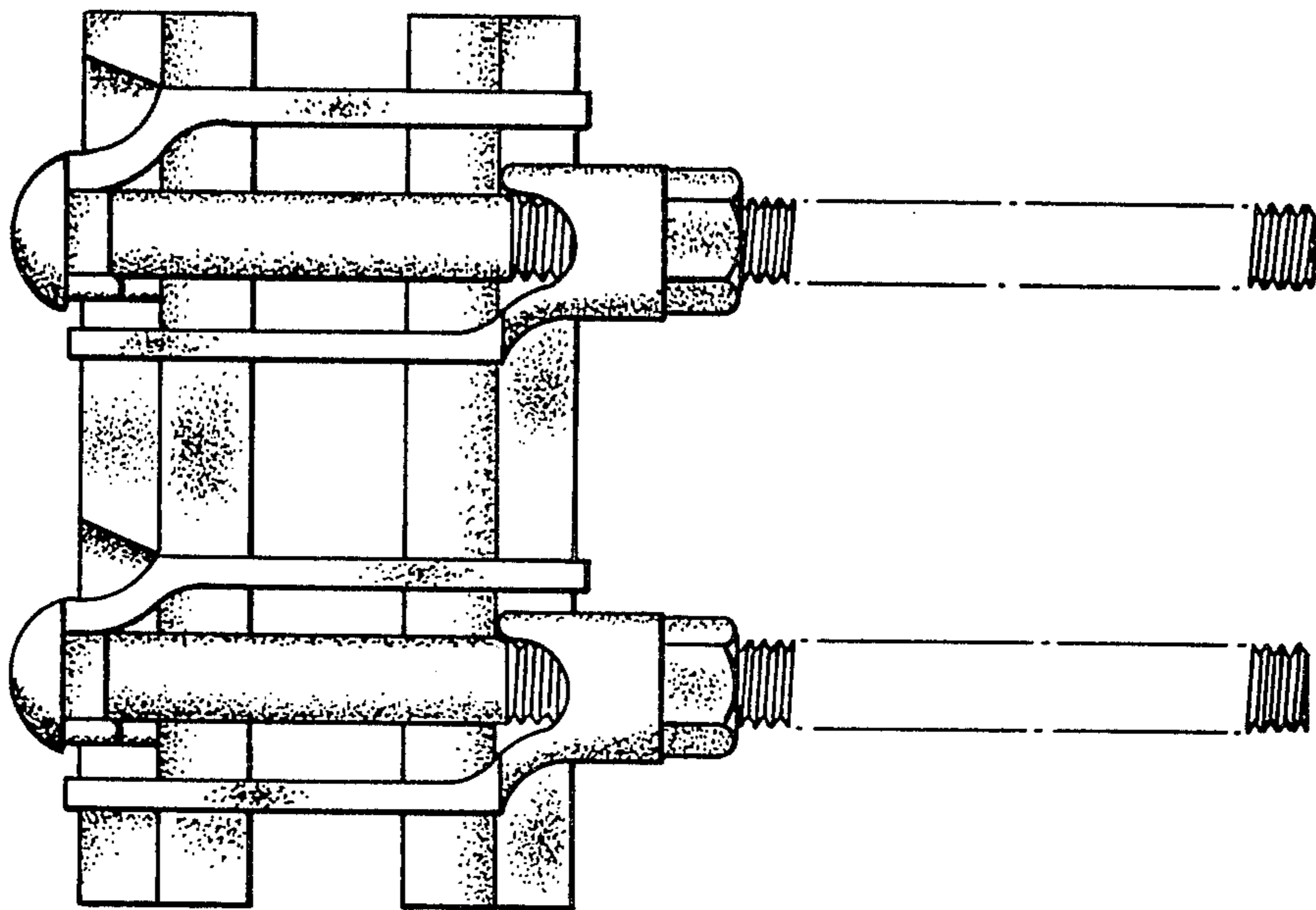

FIG _ 1

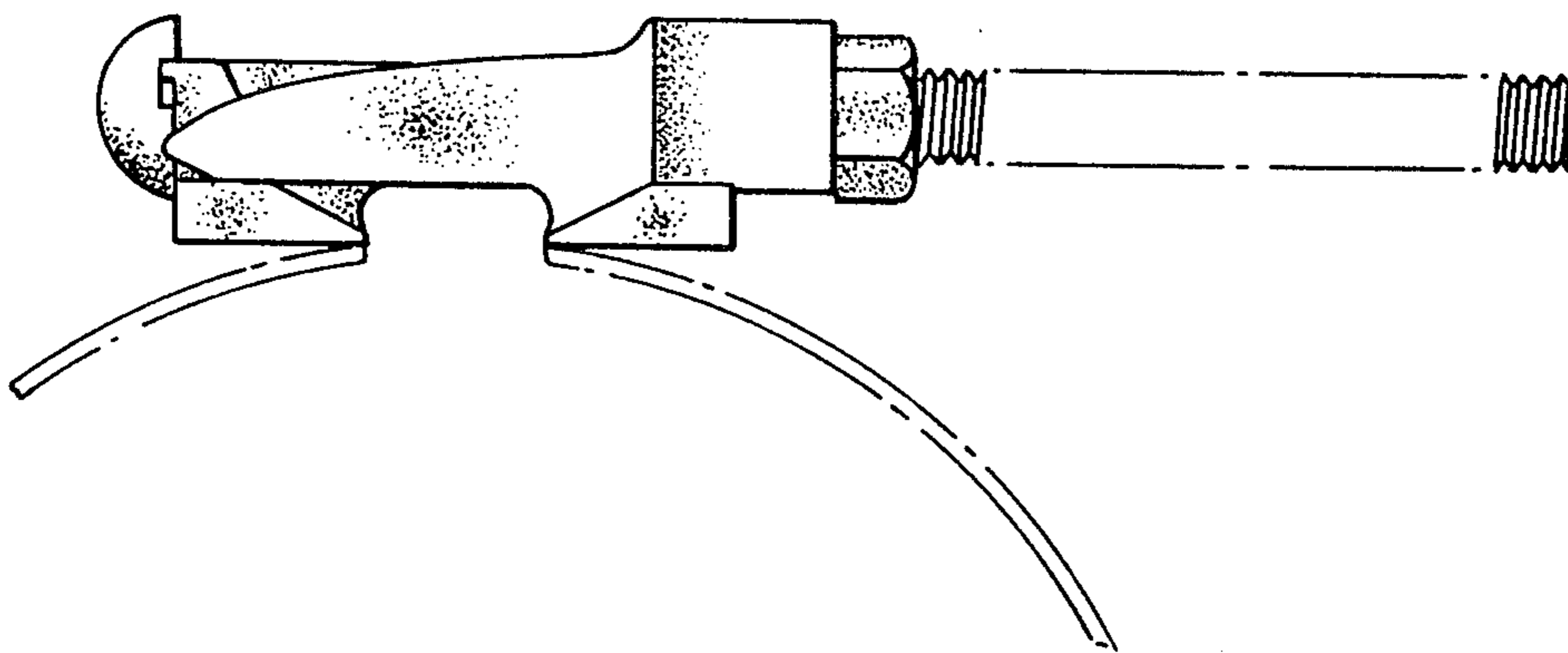

FIG _ 2

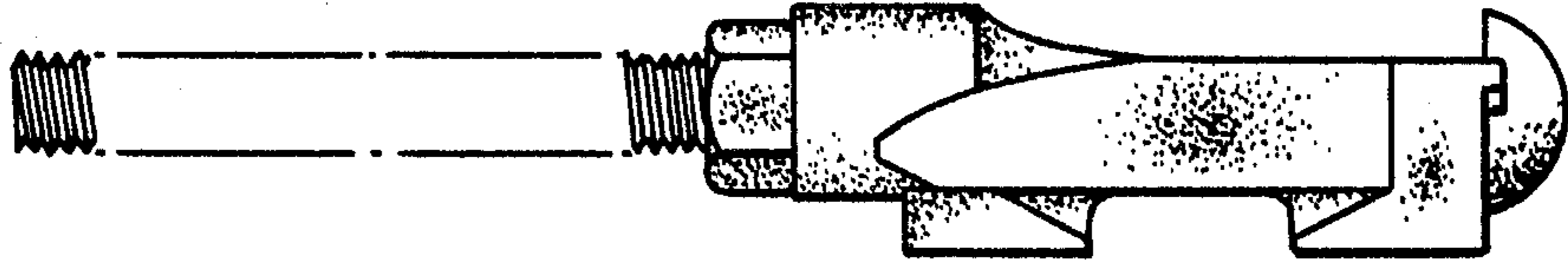

FIG _ 3

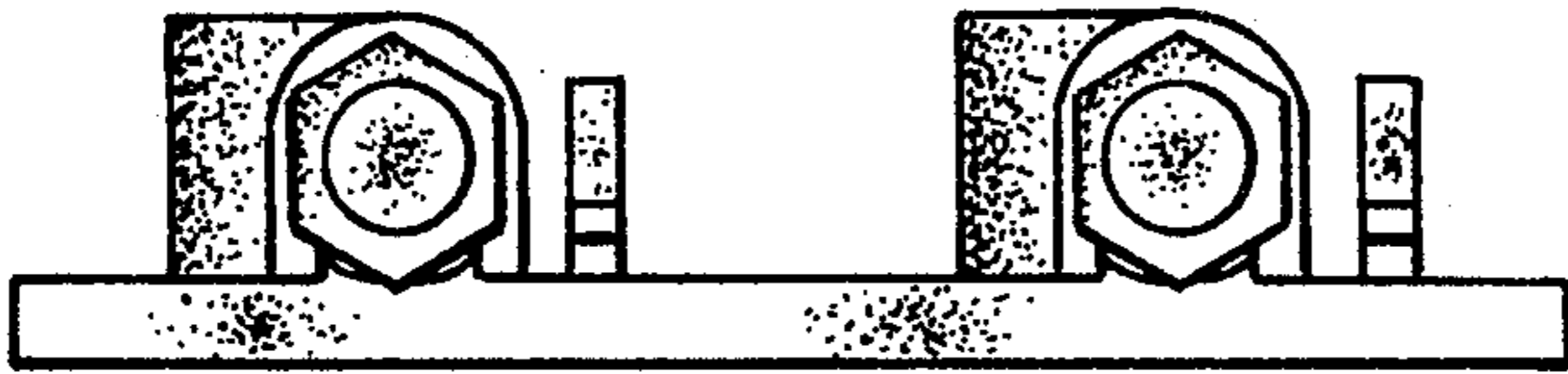

FIG _ 4



FIG _ 5

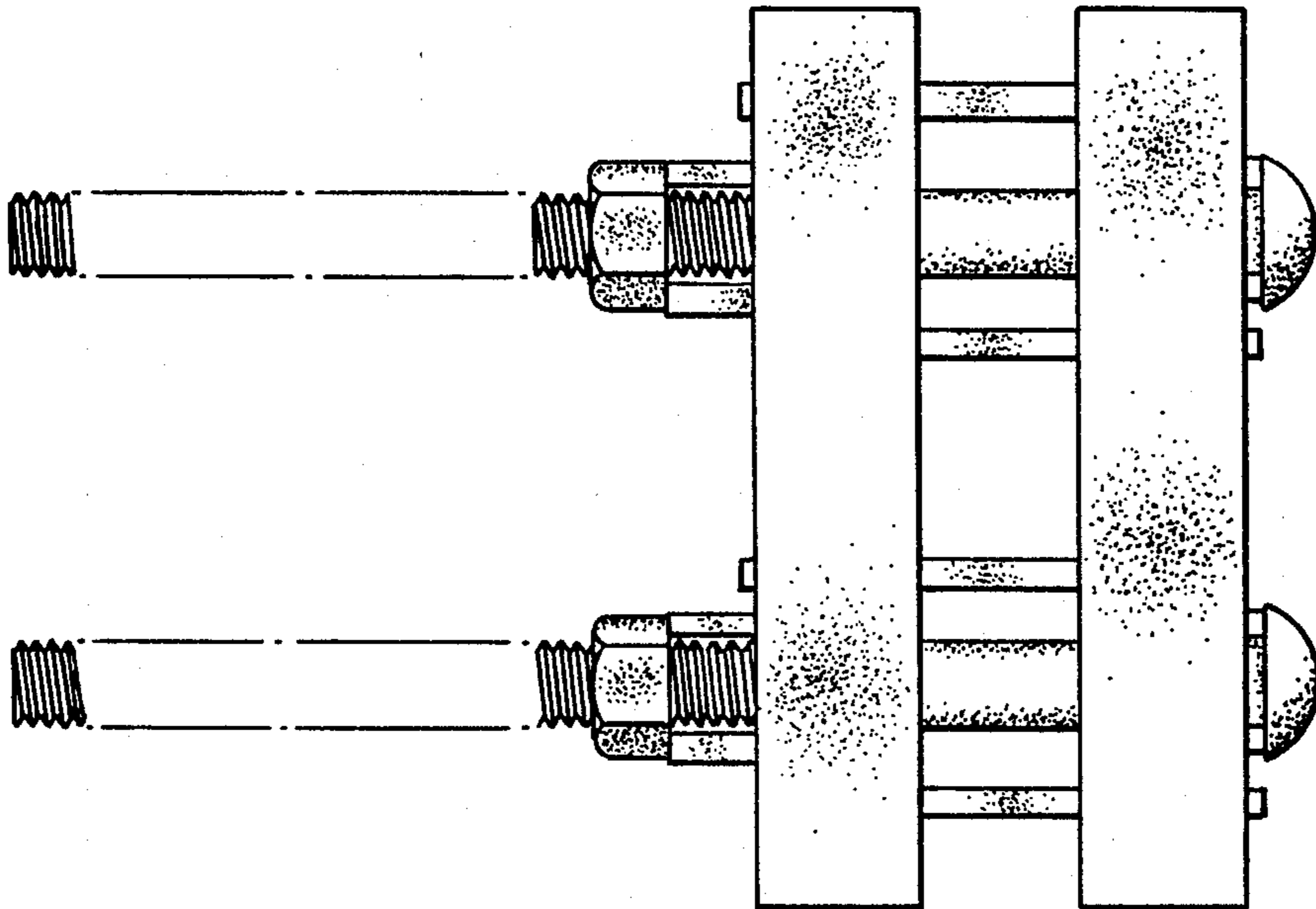

FIG _ 6