

[54] **VIDEO GAME CONTROL HOLDER**

[76] **Inventor: Kevin M. Schuster, 11662 Lampson Ave., Garden Grove, Calif. 92640**

[**] **Term: 14 Years**

[21] **Appl. No.: 325,099**

[22] **Filed: Nov. 27, 1981**

[52] **U.S. Cl. D6/512; D6/466**

[58] **Field of Search D6/85, 181; D21/19, D21/108; D34/54, 55; 223/46**

[56] **References Cited**

U.S. PATENT DOCUMENTS

D. 33,204 9/1900 Pyle D21/19
3,590,499 7/1971 Rinehuls D21/108 X

3,754,692 8/1973 Sanders 223/46

Primary Examiner—Bernard Ansher
Assistant Examiner—Carmen H. Vales
Attorney, Agent, or Firm—Hubbard & Stetina

[57] **CLAIM**

The ornamental design for a video game control holder, as shown and described.

DESCRIPTION

FIG. 1 is a top perspective view of the video game control holder showing my new design; FIG. 2 is a front elevational view thereof; and FIG. 3 is a top plan view thereof; FIG. 4 is a side elevational view thereof. The broken lines depicted in FIGS. 2 and 4 in the drawings are for illustrative purposes only.

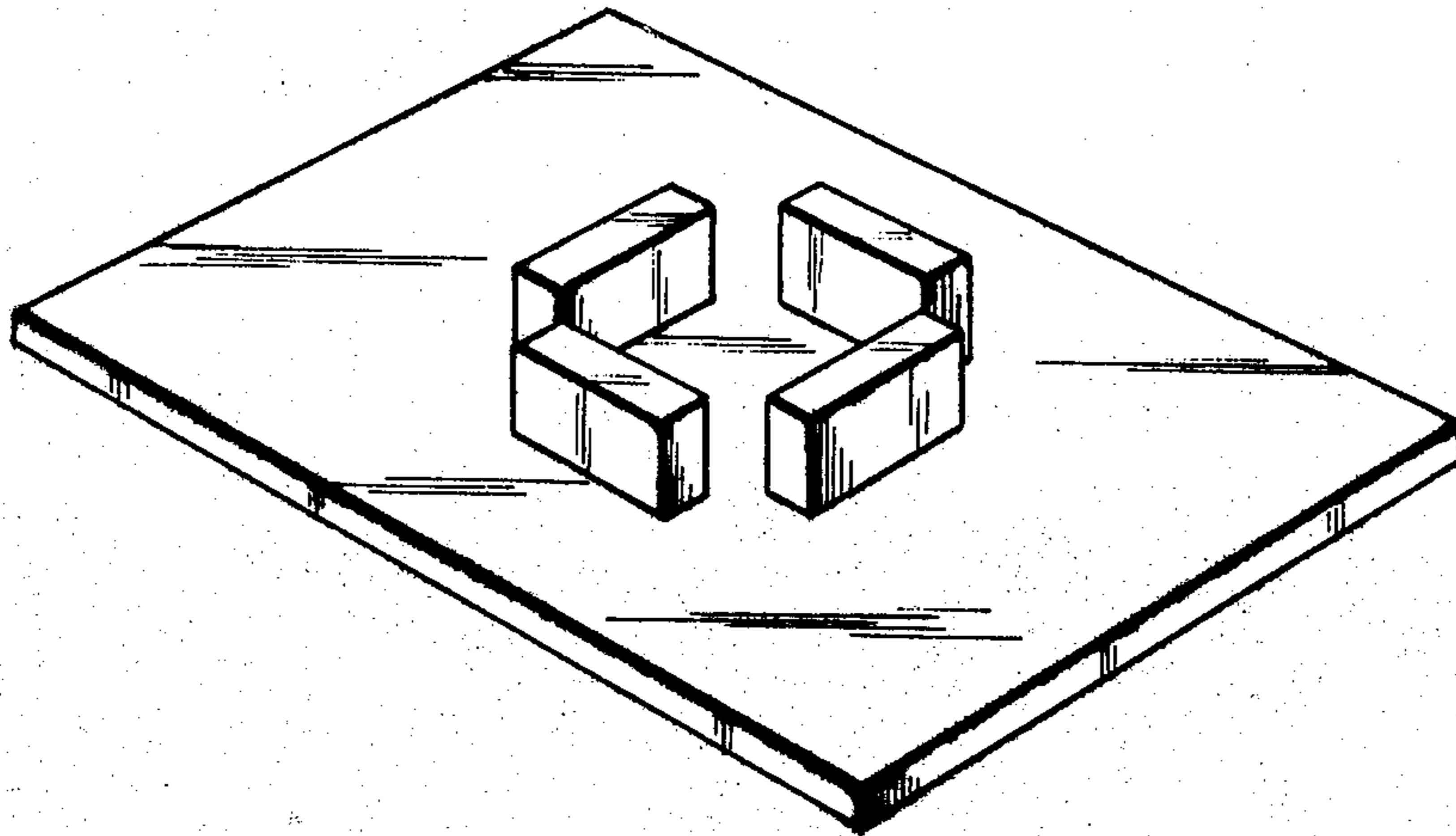

Fig. 1

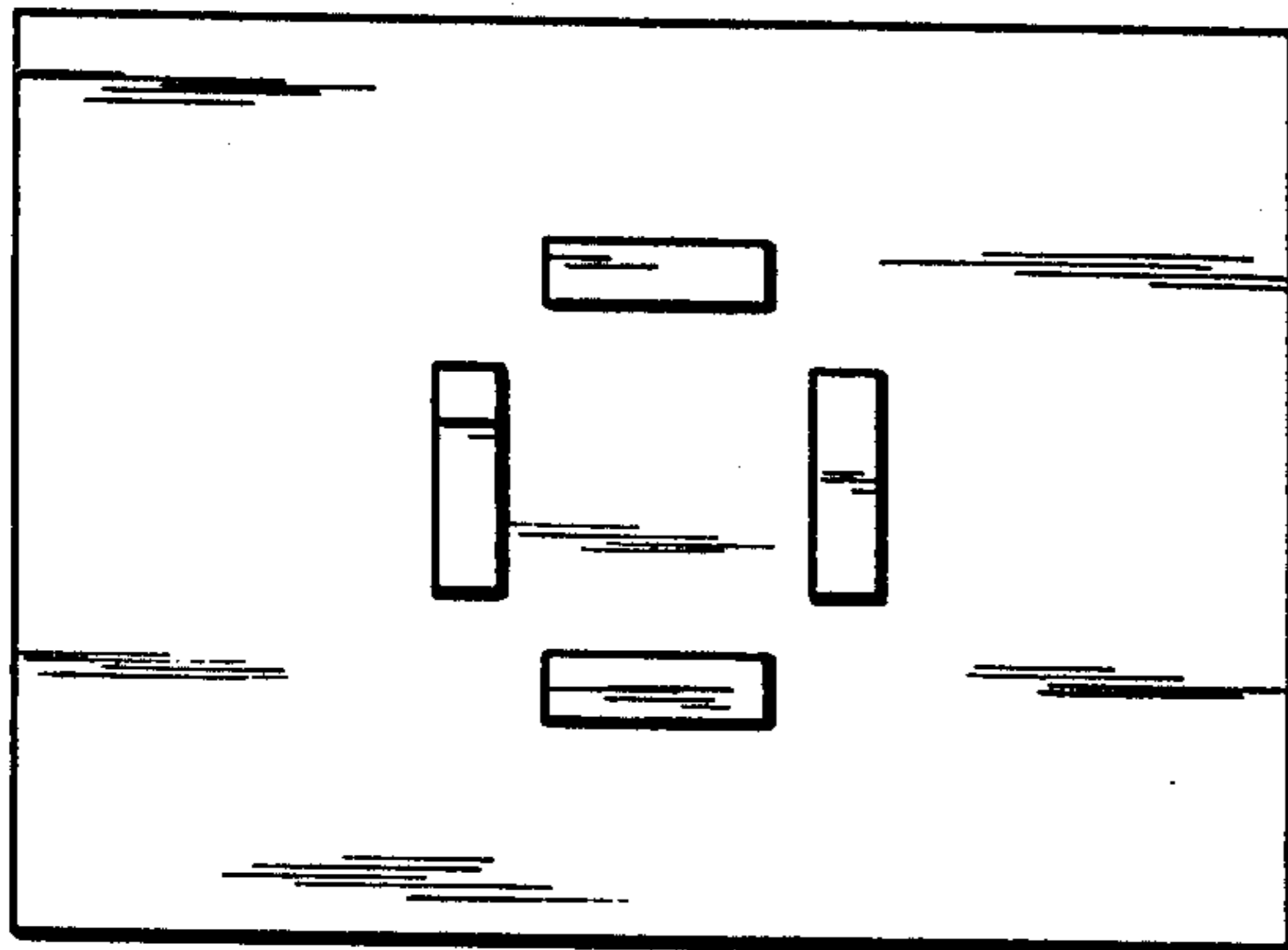
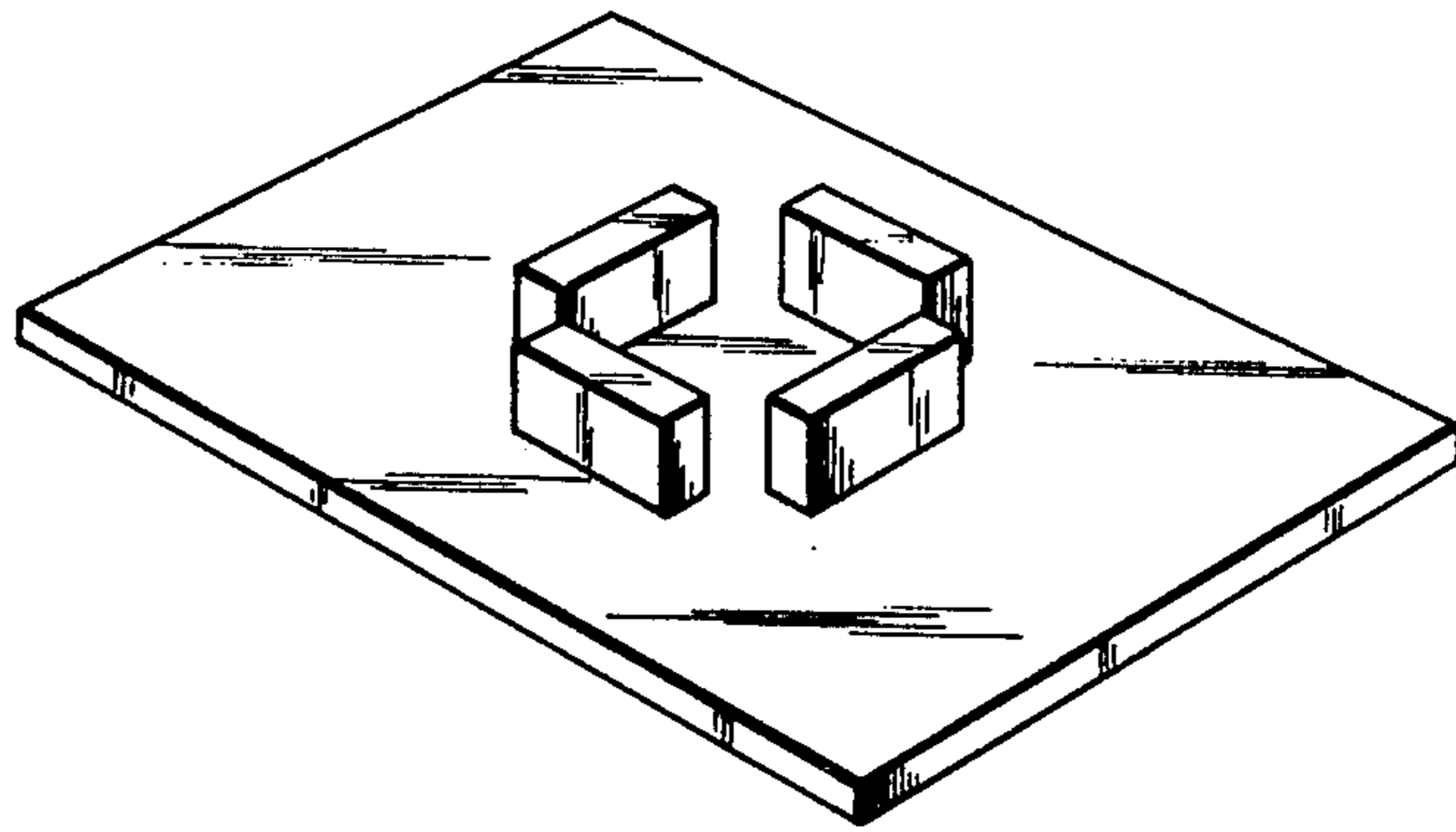

Fig. 3

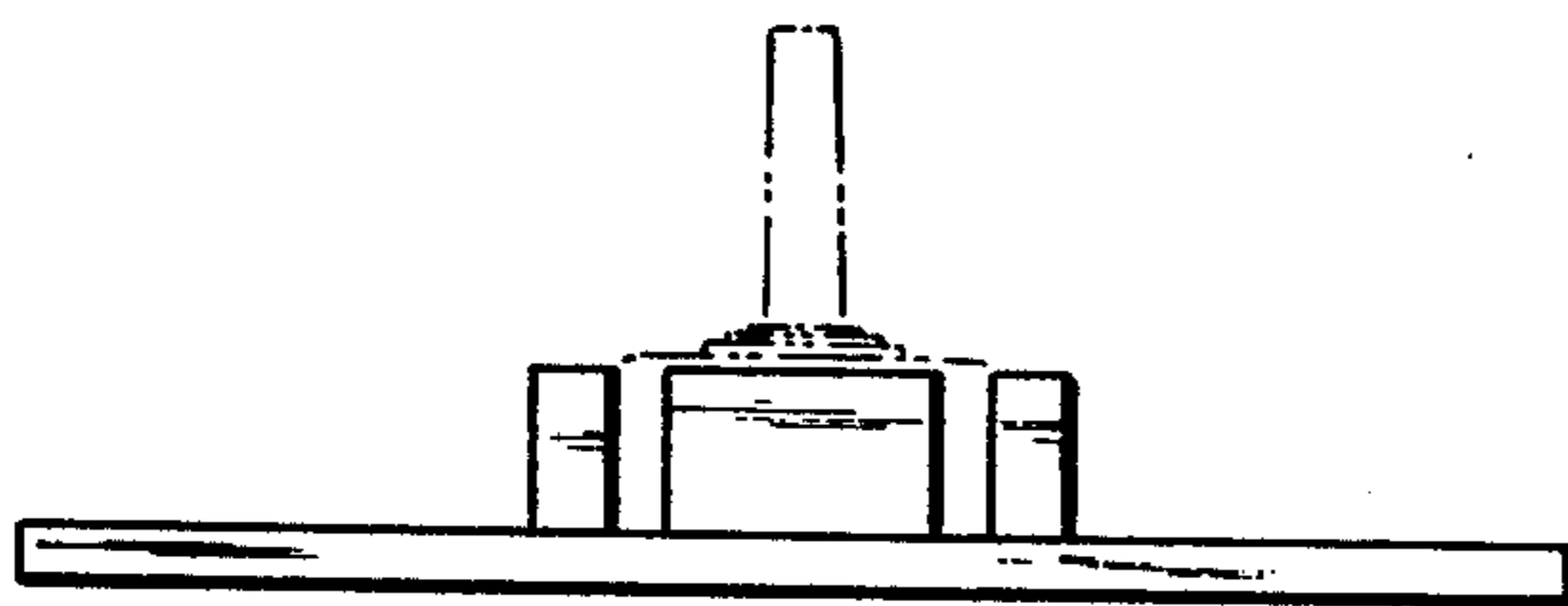

Fig. 2

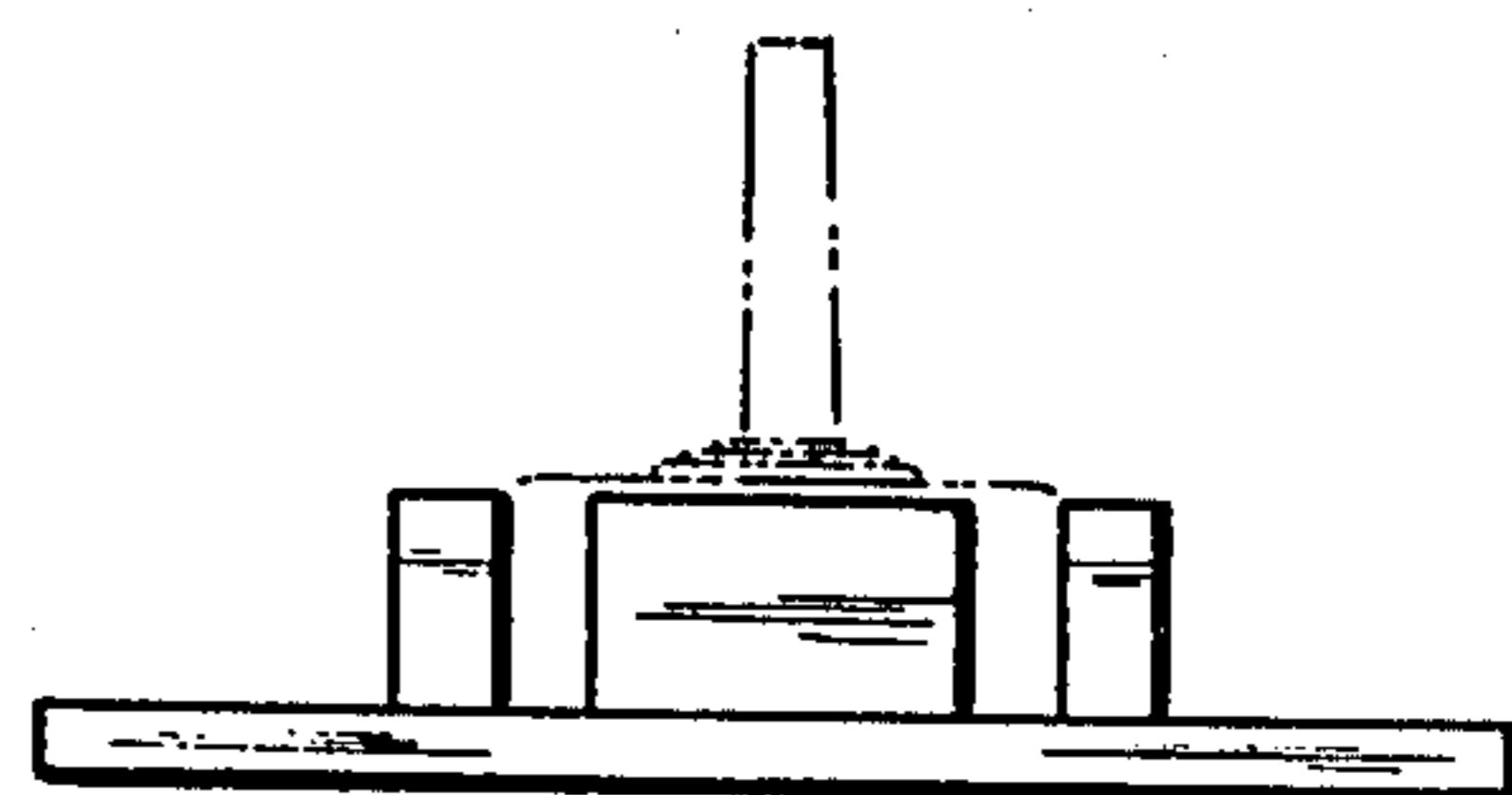

Fig. 4