

United States Patent [19]

Tuggle et al.

[11] Patent Number: **Des. 276,160**

[45] Date of Patent: **** Oct. 30, 1984**

[54] **INTERNAL COMBUSTION ENGINE POWER UNIT**

3,252,452 5/1966 Burkett et al. 123/56 BA

[75] Inventors: **Lloyd H. Tuggle**, Shreveport; **Ronald C. Loyd**, Keithville; **Charles A. Fain**, Shreveport, all of La.

[73] Assignee: **Emerson Electric Co.**, Shreveport, La.

[**] Term: **14 Years**

[21] Appl. No.: **397,988**

[22] Filed: **Jul. 14, 1982**

[52] U.S. Cl. **D15/1**

[58] Field of Search **D15/1, 3; 123/56 B, 123/56 BC, 56 BA, 41.66, 41.67, 41.7, 195 C, 198 E, 41.74, 41.82, 41.83, 41.69**

[56] **References Cited**

U.S. PATENT DOCUMENTS

D. 169,943	6/1953	Mall et al.	D15/1
D. 175,136	7/1955	Stevens	D15/1
D. 224,811	9/1972	Burkett et al.	D15/1
D. 227,177	6/1973	Cookson	D15/1

OTHER PUBLICATIONS

Implement & Tractor, Mar. 21, 1979, p. 11, Kawasaki Engines.

Primary Examiner—Wallace R. Burke

Assistant Examiner—Lynn Wilder

Attorney, Agent, or Firm—Hubbard, Thurman, Turner & Tucker

[57] CLAIM

The ornamental design for an internal combustion engine power unit, as shown and described.

DESCRIPTION

FIG. 1 is a front perspective view of an internal combustion engine power unit showing our new design; FIG. 2 is a rear perspective view thereof; FIG. 3 is a left side elevational view thereof; FIG. 4 is a rear elevational view thereof; FIG. 5 is a right side elevational view thereof; FIG. 6 is a front elevational view thereof; FIG. 7 is a top plan view thereof; and FIG. 8 is a bottom plan view thereof.

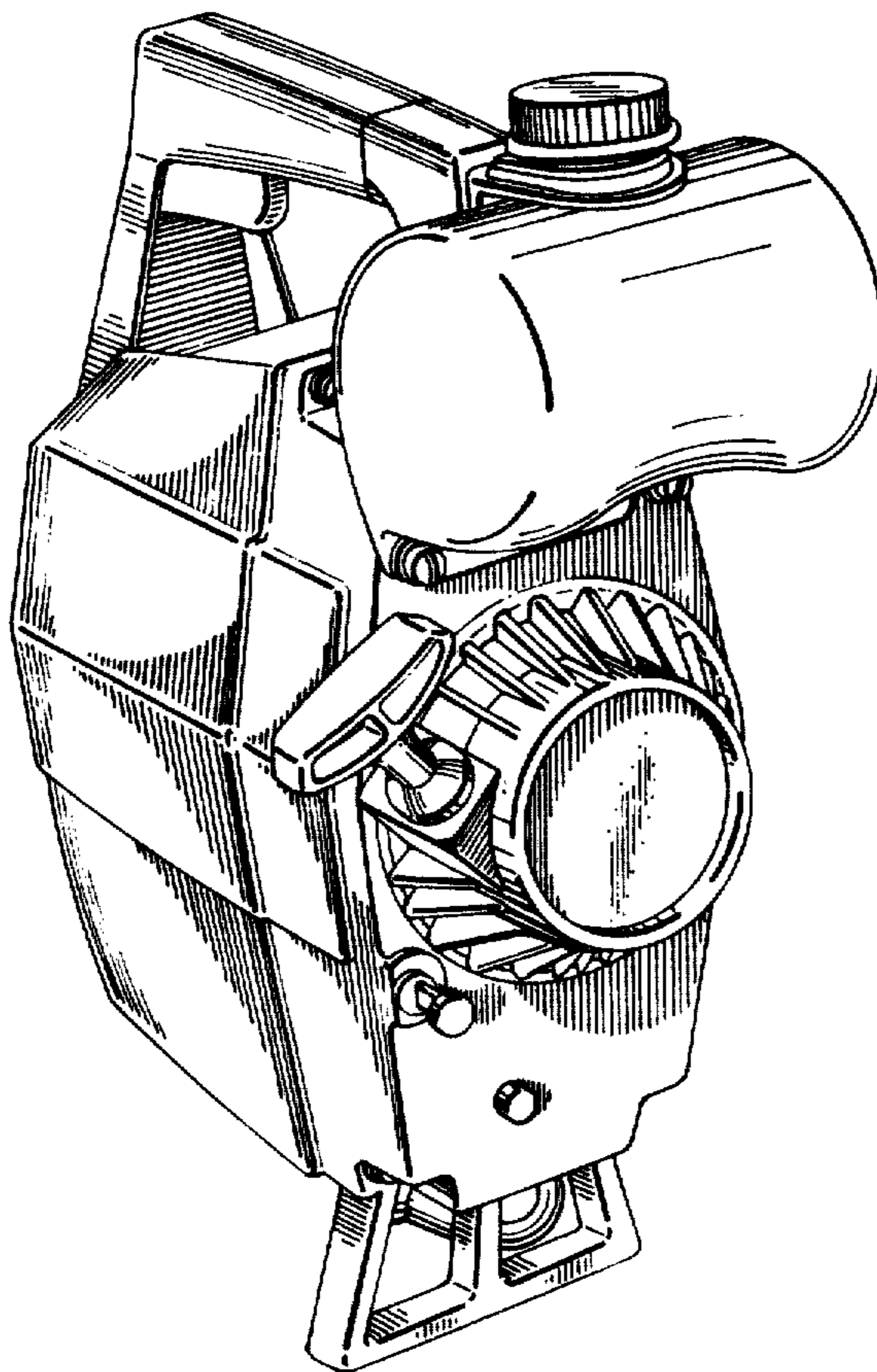

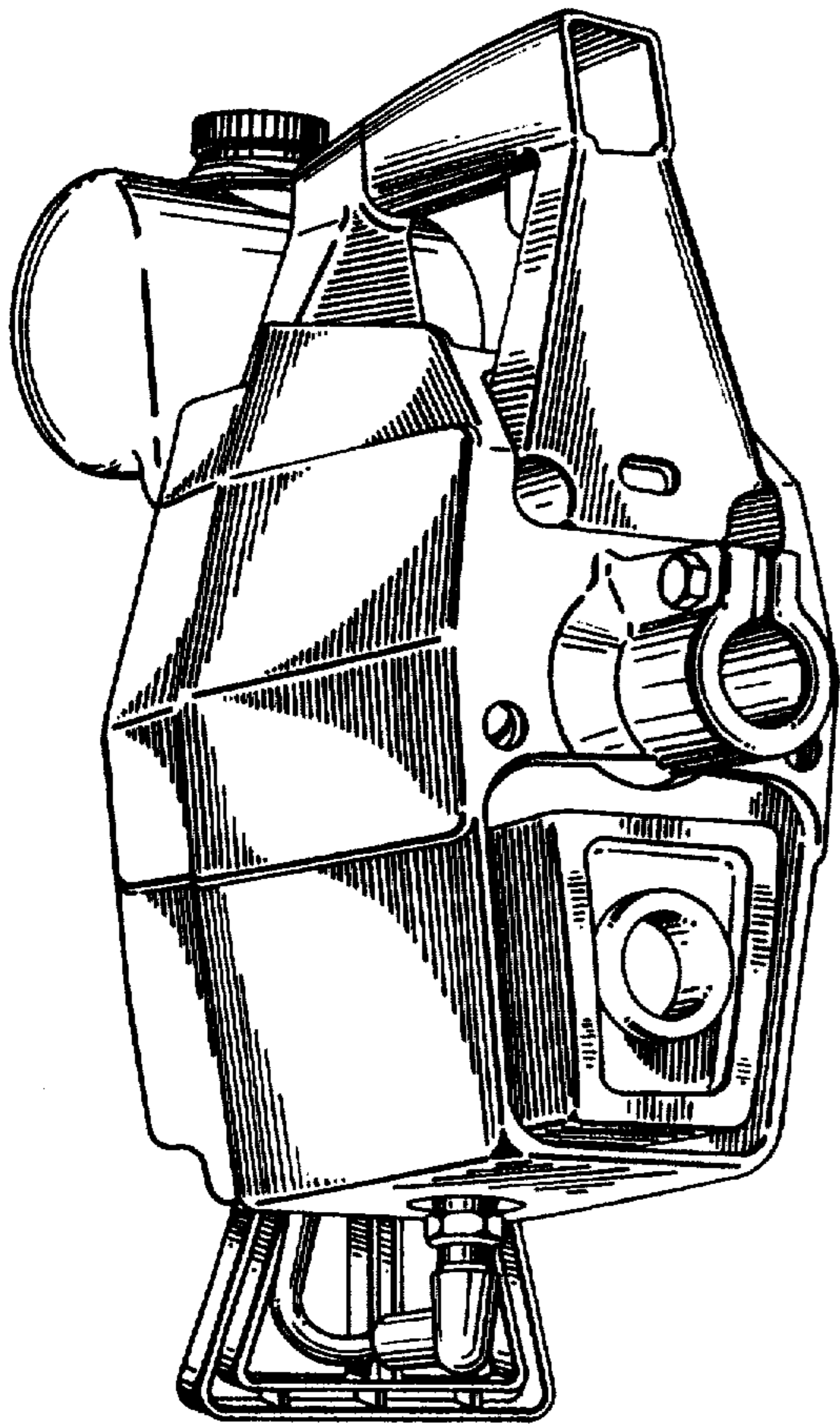

FIG. 1

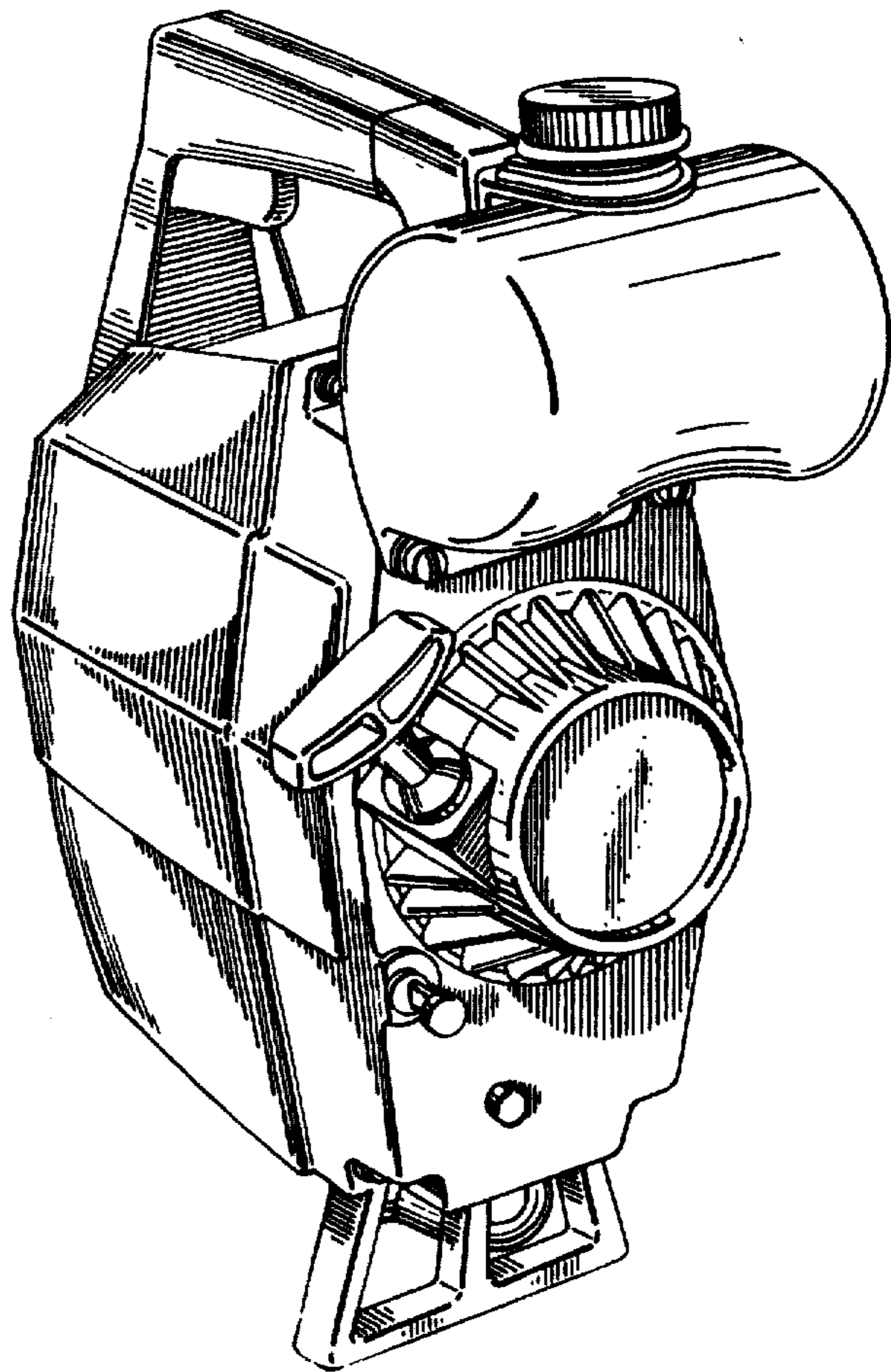

FIG. 2

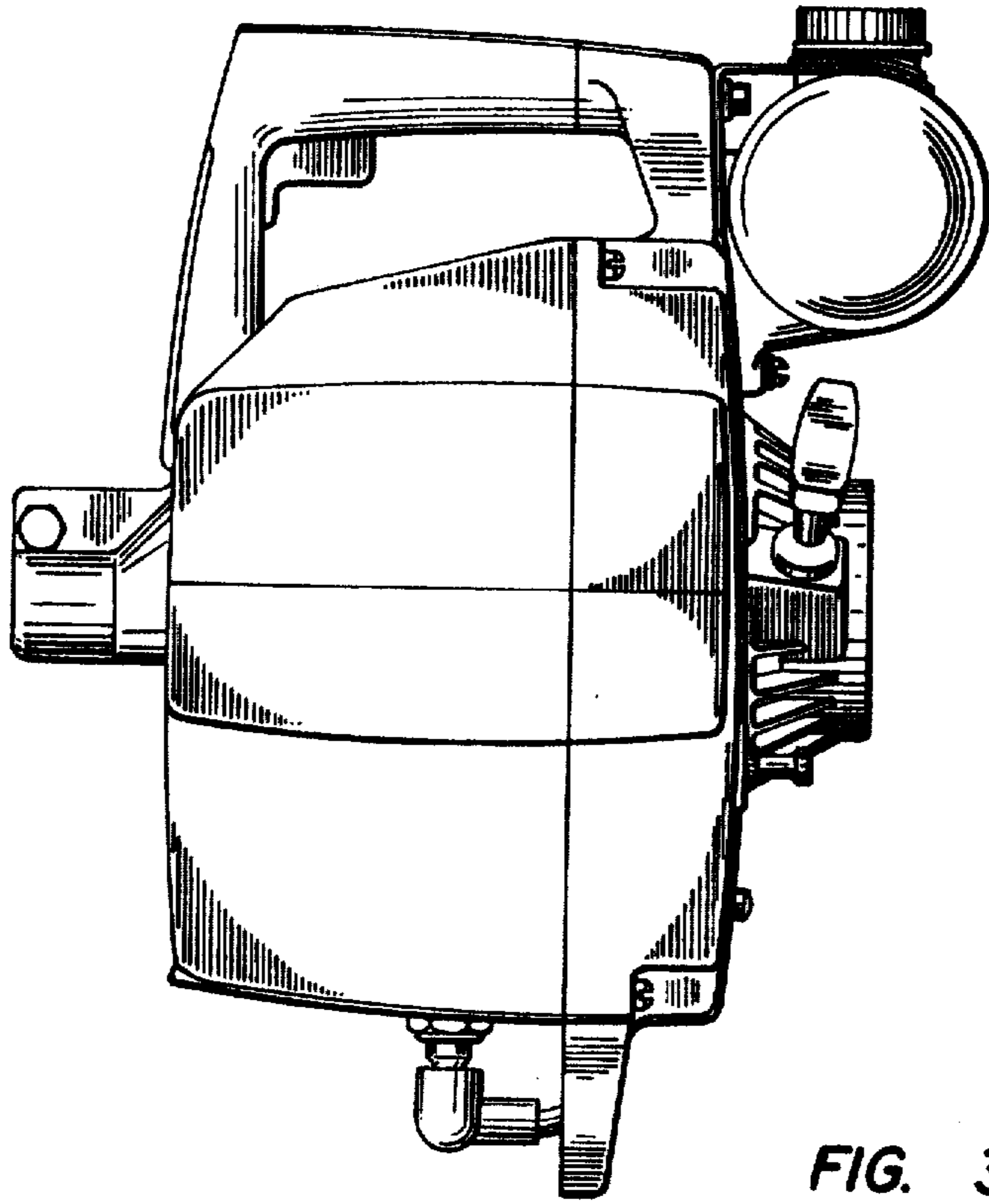

FIG. 3

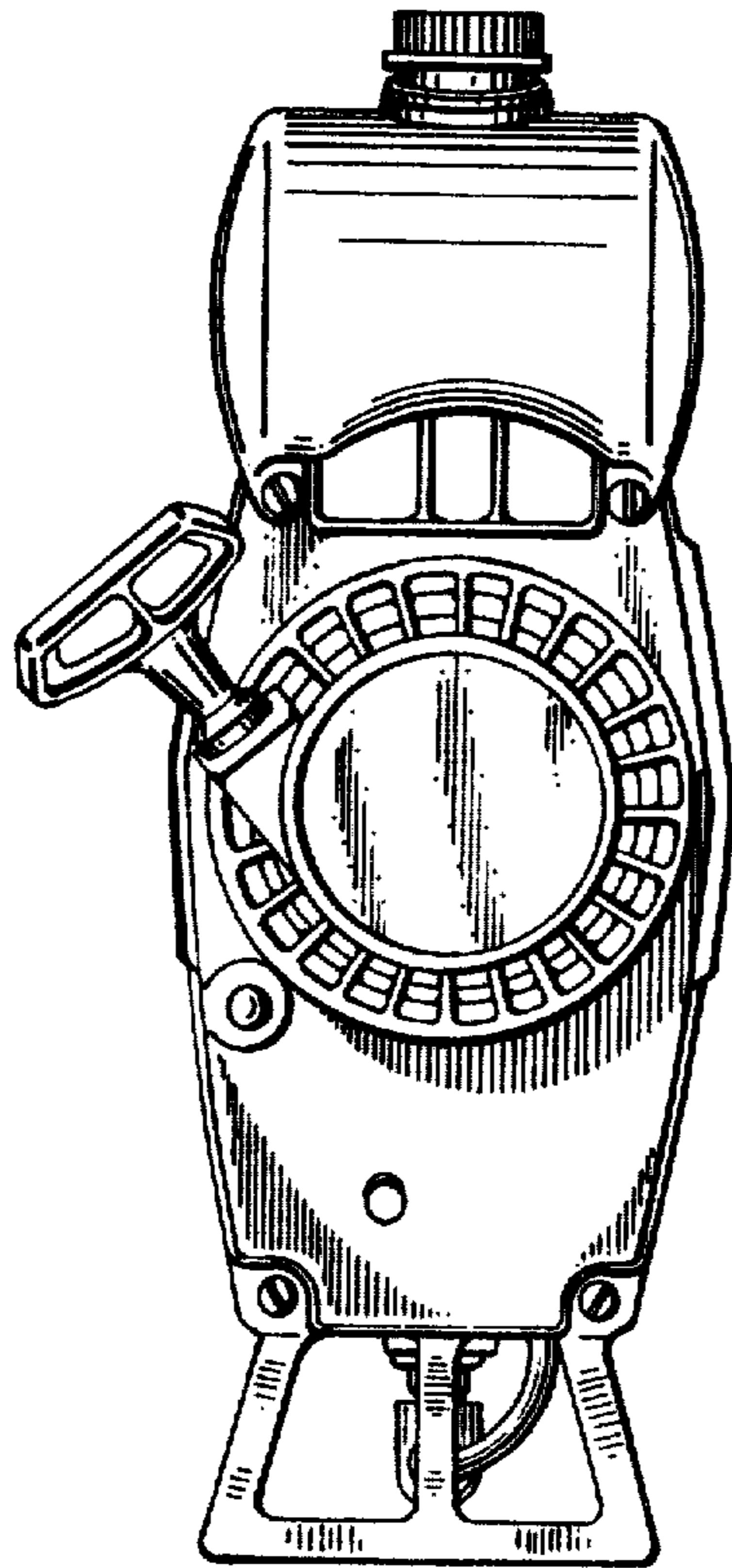

FIG. 4

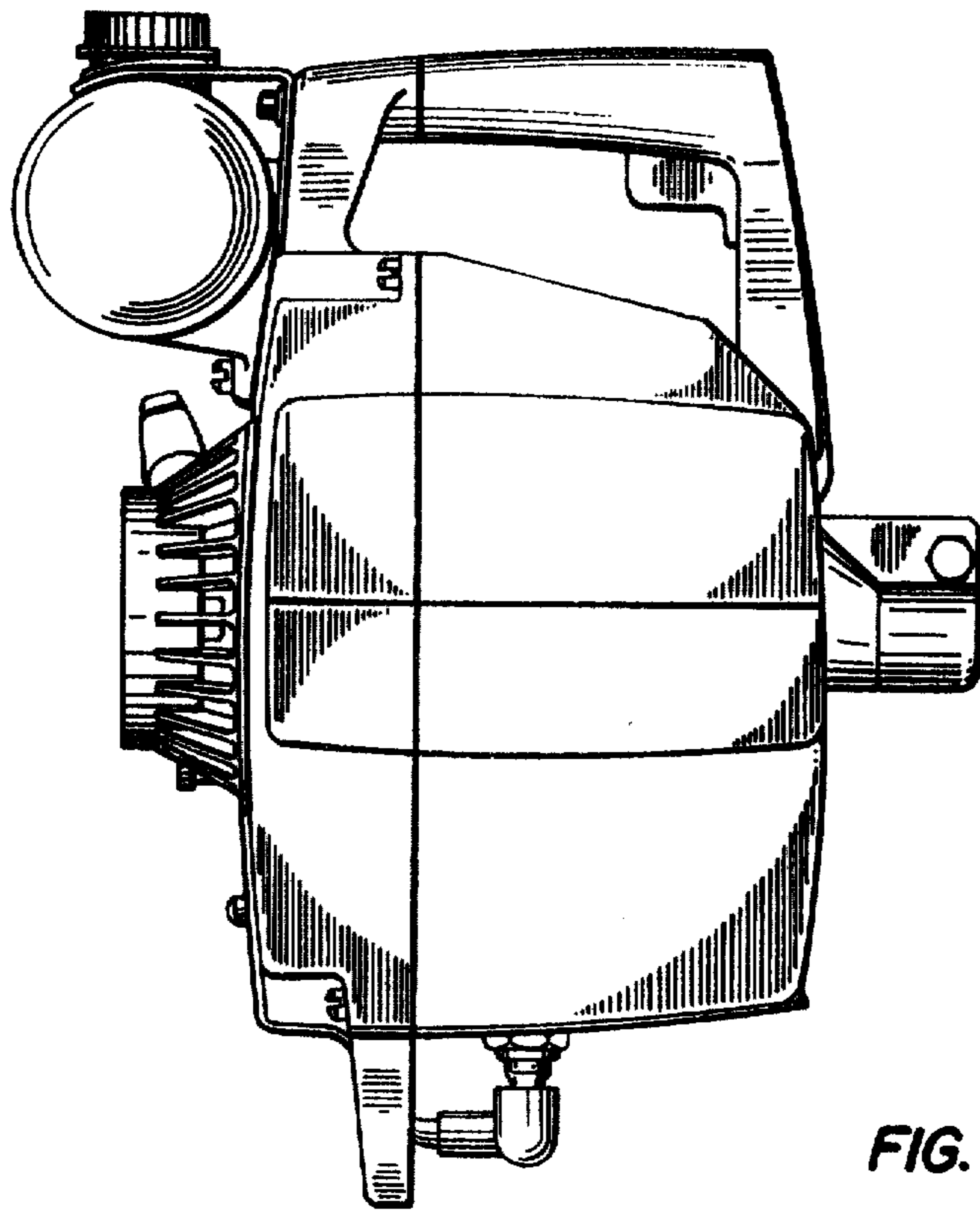

FIG. 5

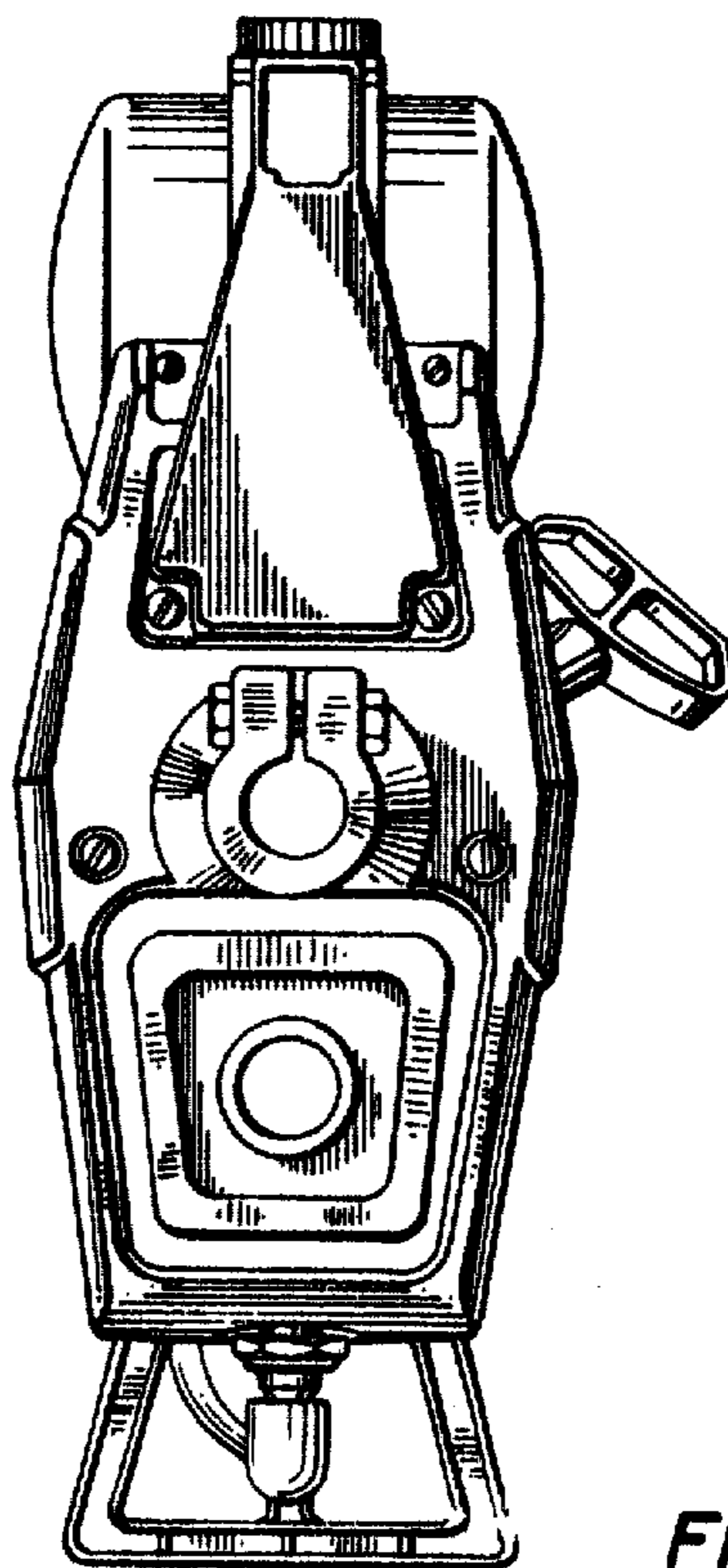

FIG. 6

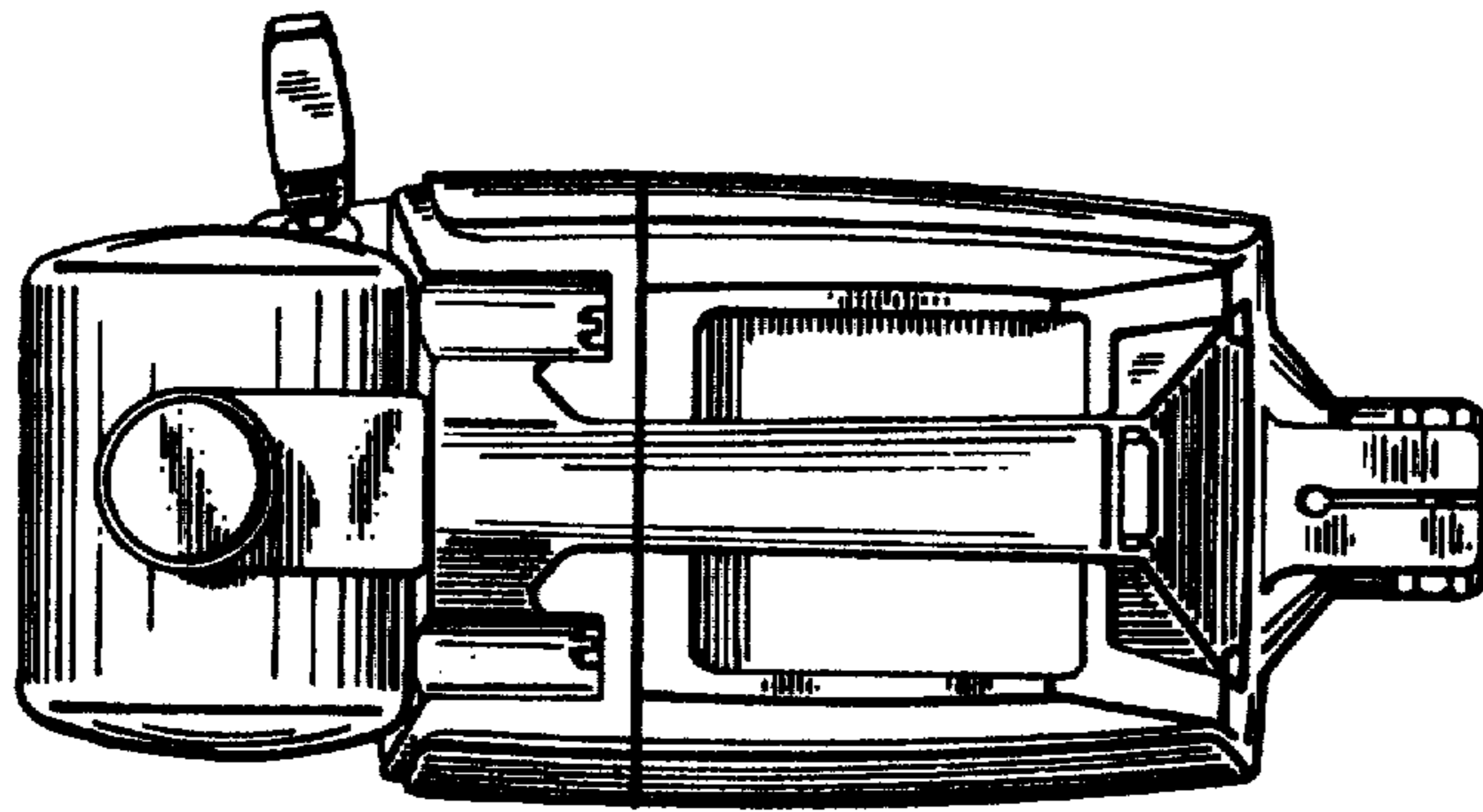

FIG. 7

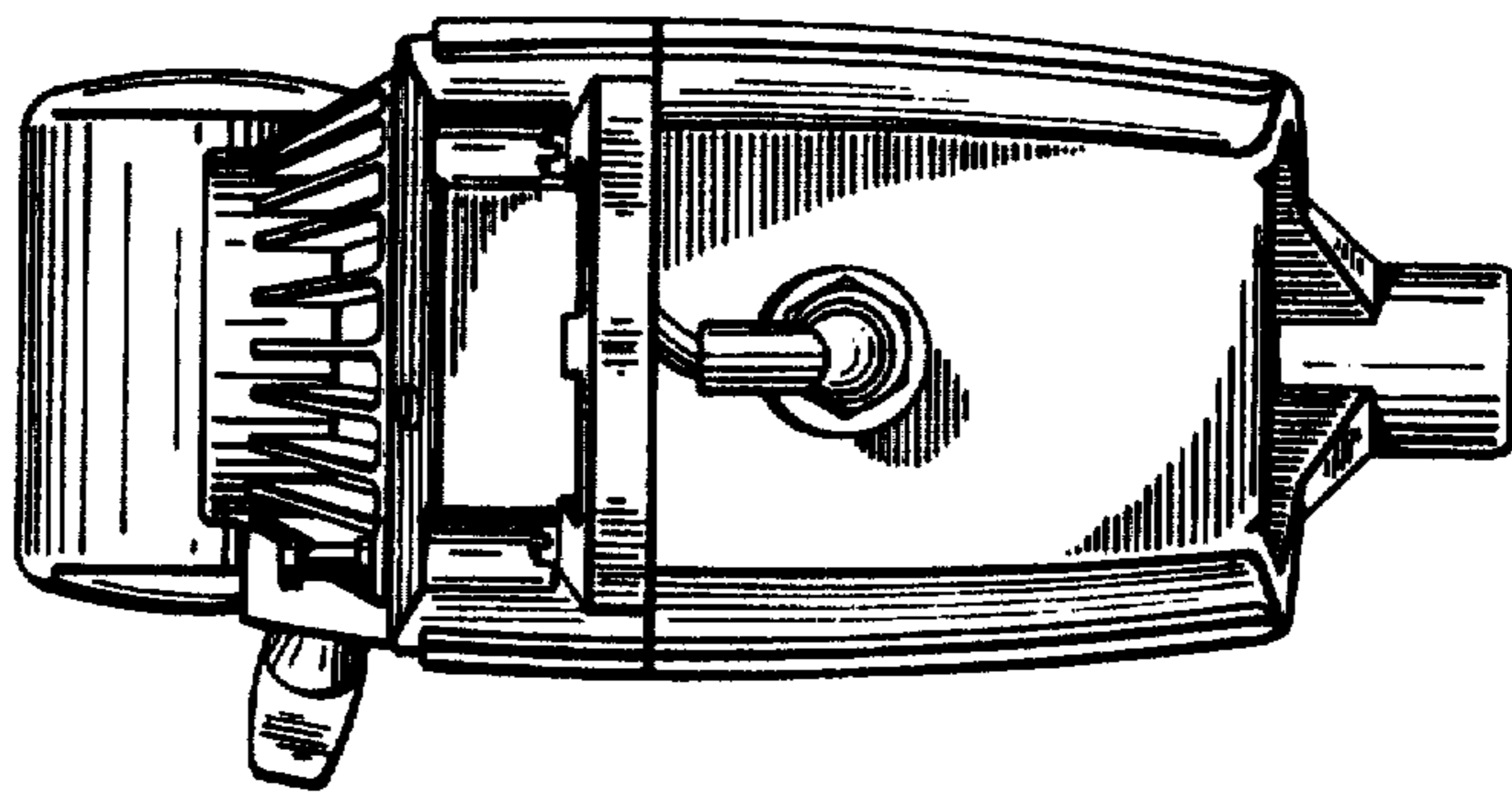

FIG. 8