

[54] BOAT

[75] Inventor: Juichi Arima, King County, Wash.

[73] Assignee: Arima Marine International, Inc.,
Seattle, Wash.

[**] Term: 14 Years

[21] Appl. No.: 336,569

[22] Filed: Jan. 4, 1982

[52] U.S. Cl. D12/314; D12/300

[58] Field of Search D12/300, 314

[56] References Cited

U.S. PATENT DOCUMENTS

D. 202,591	10/1965	Lowe	D12/300
D. 214,101	5/1969	Simpkins	D12/314
D. 221,808	9/1971	Simpkins	D12/314
D. 236,333	8/1975	Livingstone	D12/314

OTHER PUBLICATIONS

AMF Crestliner Boats Catalog, p. 27, boat at top of page.

Cruisers/Rally 1978 Boat Catalog, p. 3, Barnegat 22' Series boat in drawing at right of page.

Fiberform 1976 Catalog, p. 31, 17' bowrider boat at bottom of page.

Reinell Boat/1979 Catalog, p. 15, L2101 boat at bottom left of page.

Primary Examiner—Alan P. Douglas

Attorney, Agent, or Firm—Seed and Berry

[57] CLAIM

The ornamental design for a boat, substantially as shown and described.

DESCRIPTION

FIG. 1 is a perspective view of a boat illustrating the design of this invention.

FIG. 2 is a rear elevation view of the boat.

FIG. 3 is a side elevation view of the boat.

FIG. 4 is a top plan view of the boat.

FIG. 5 is a bottom plan view of the boat.

FIG. 6 is a front elevational view of the boat.

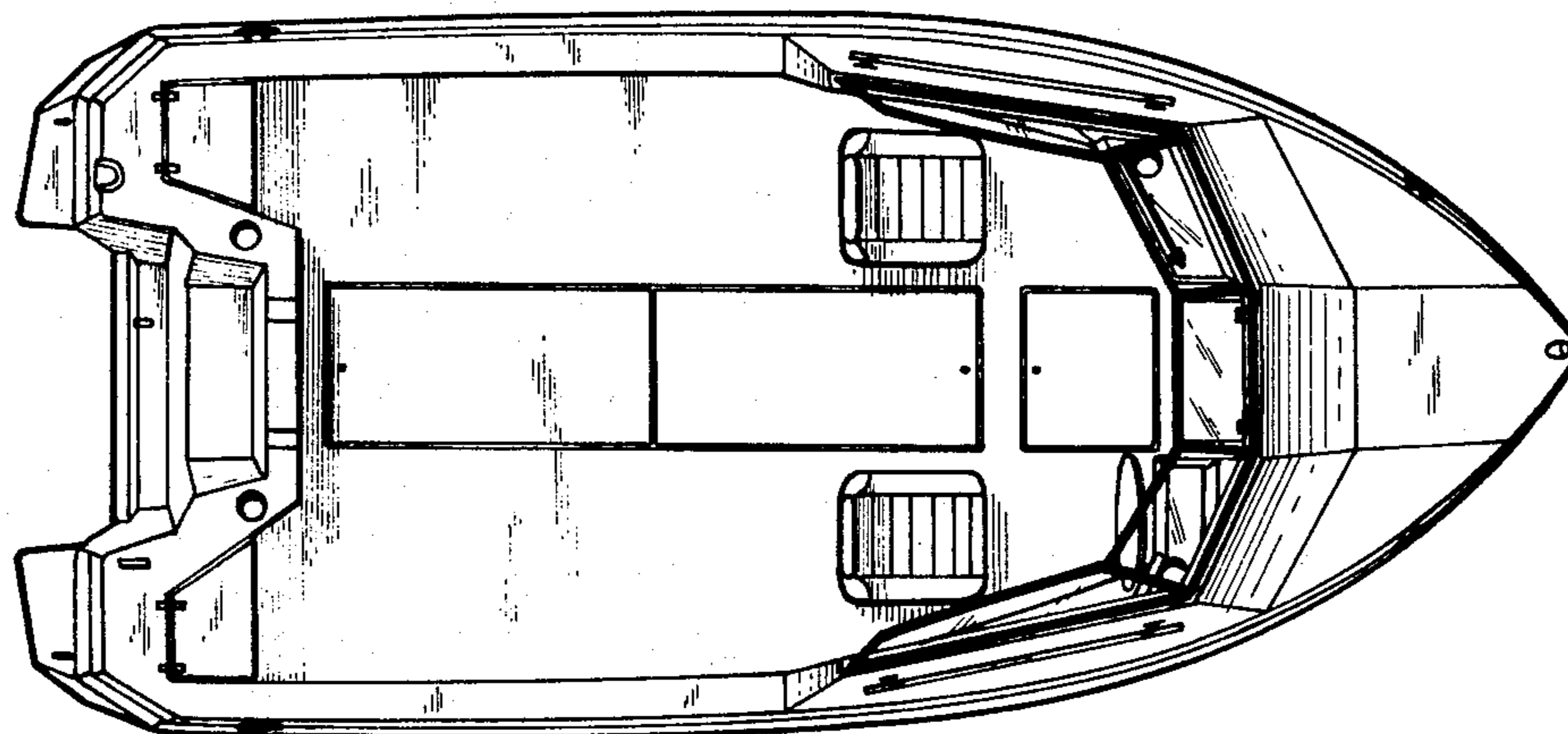
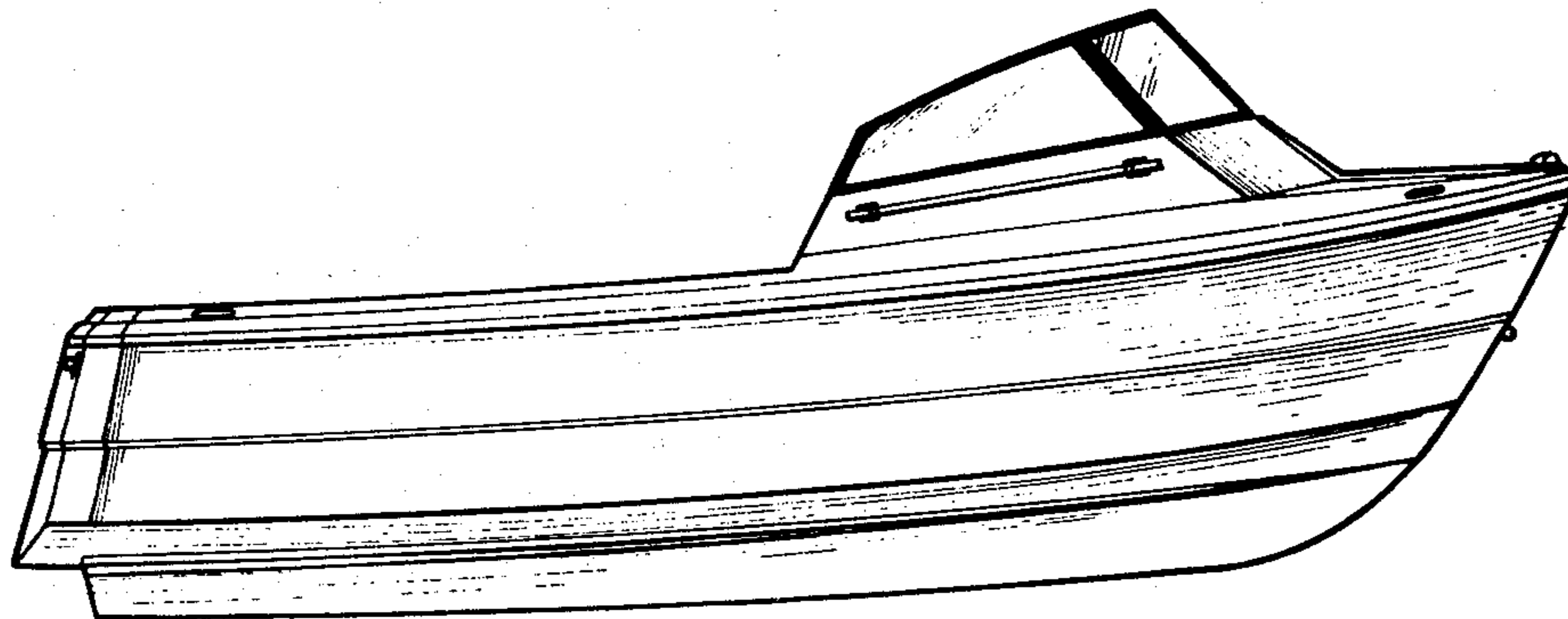

FIG. 1

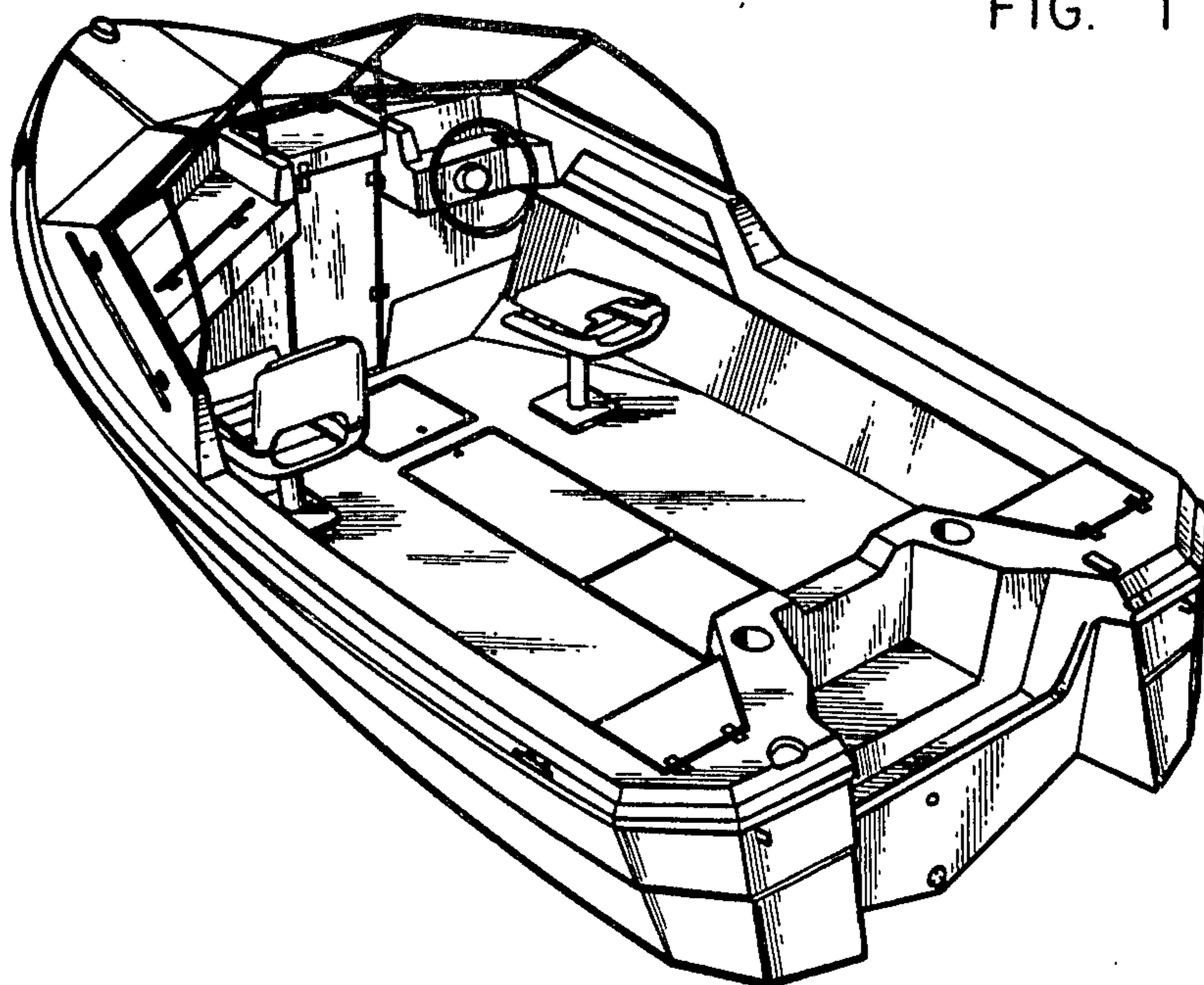

FIG. 2

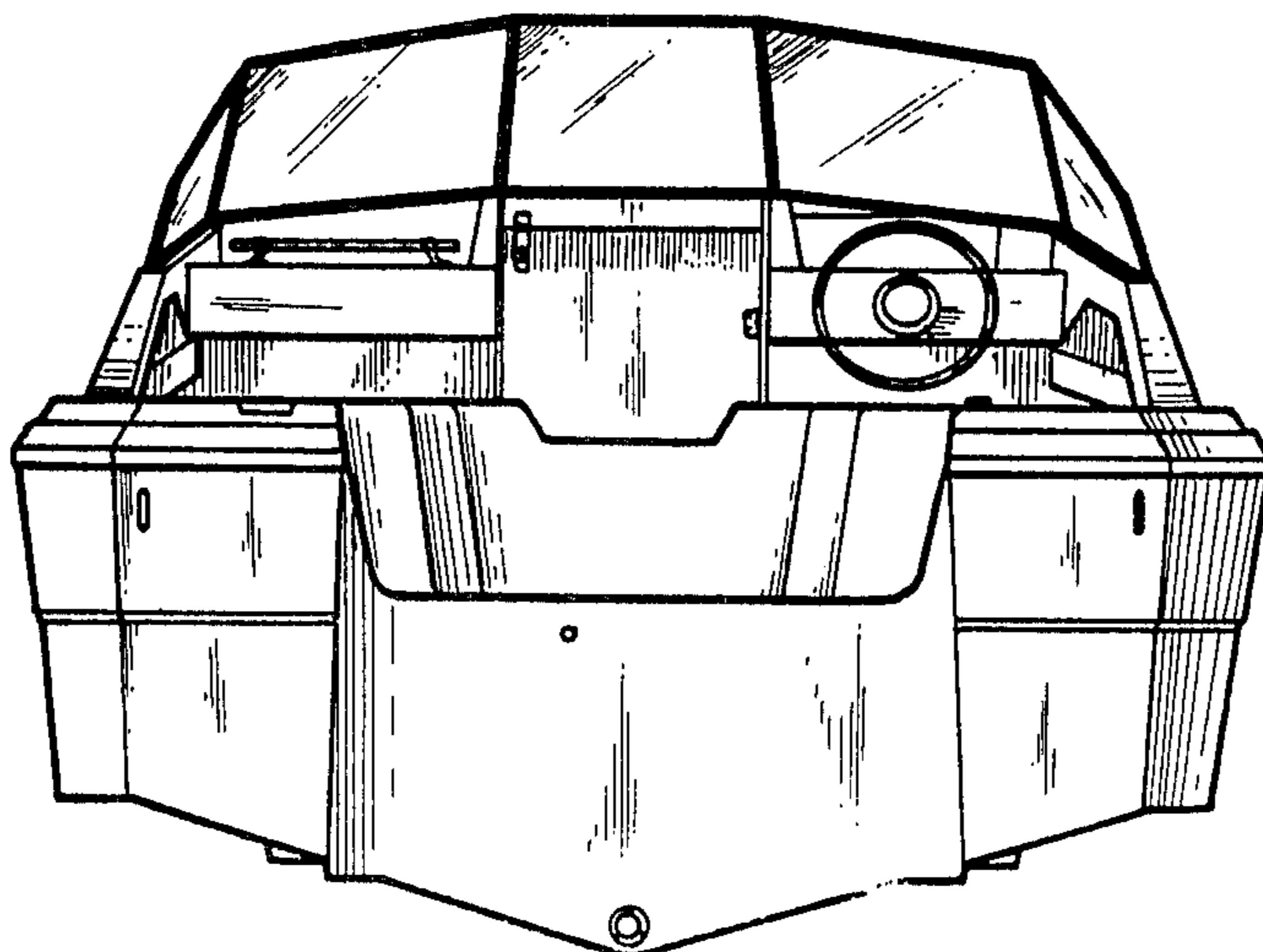

FIG. 3



FIG. 4

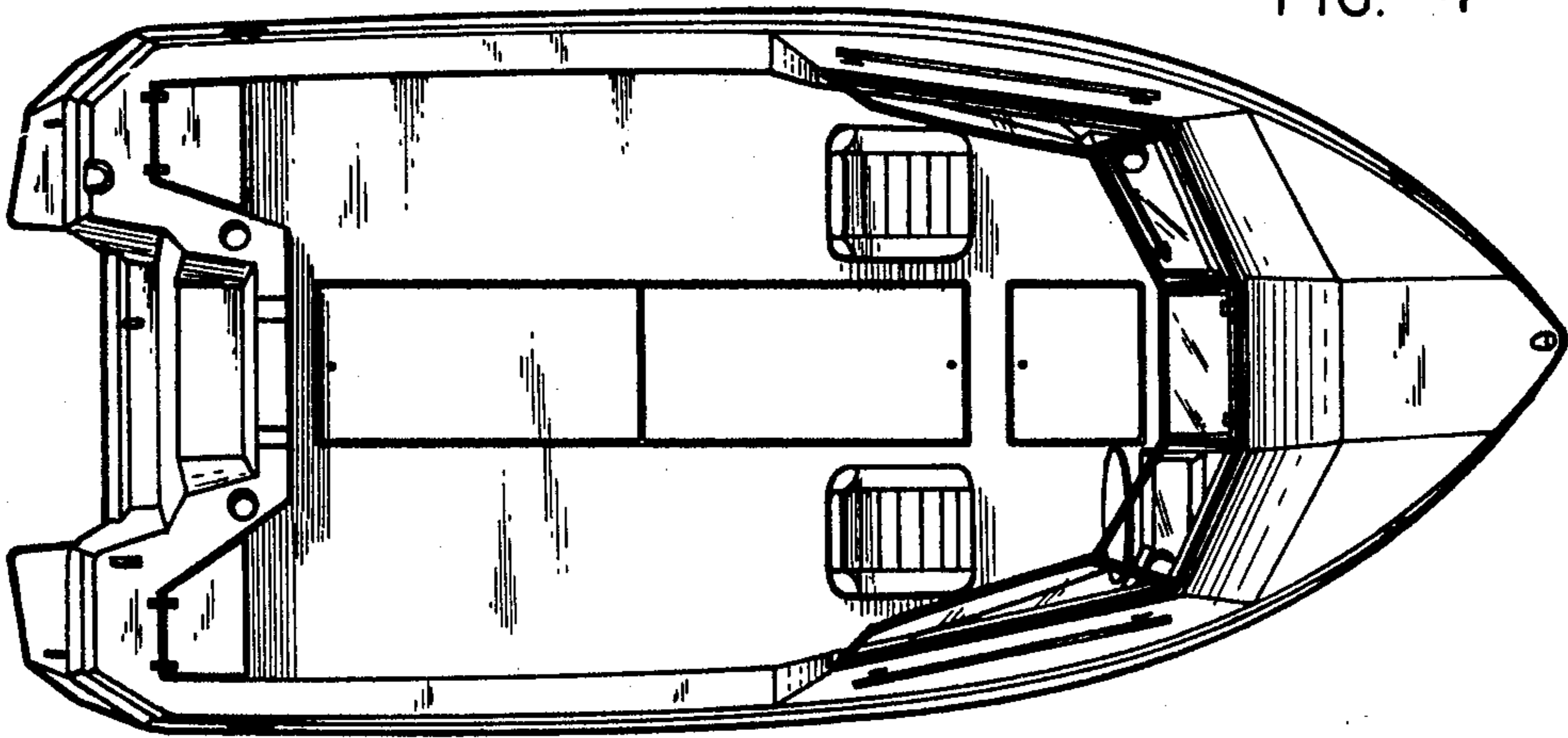
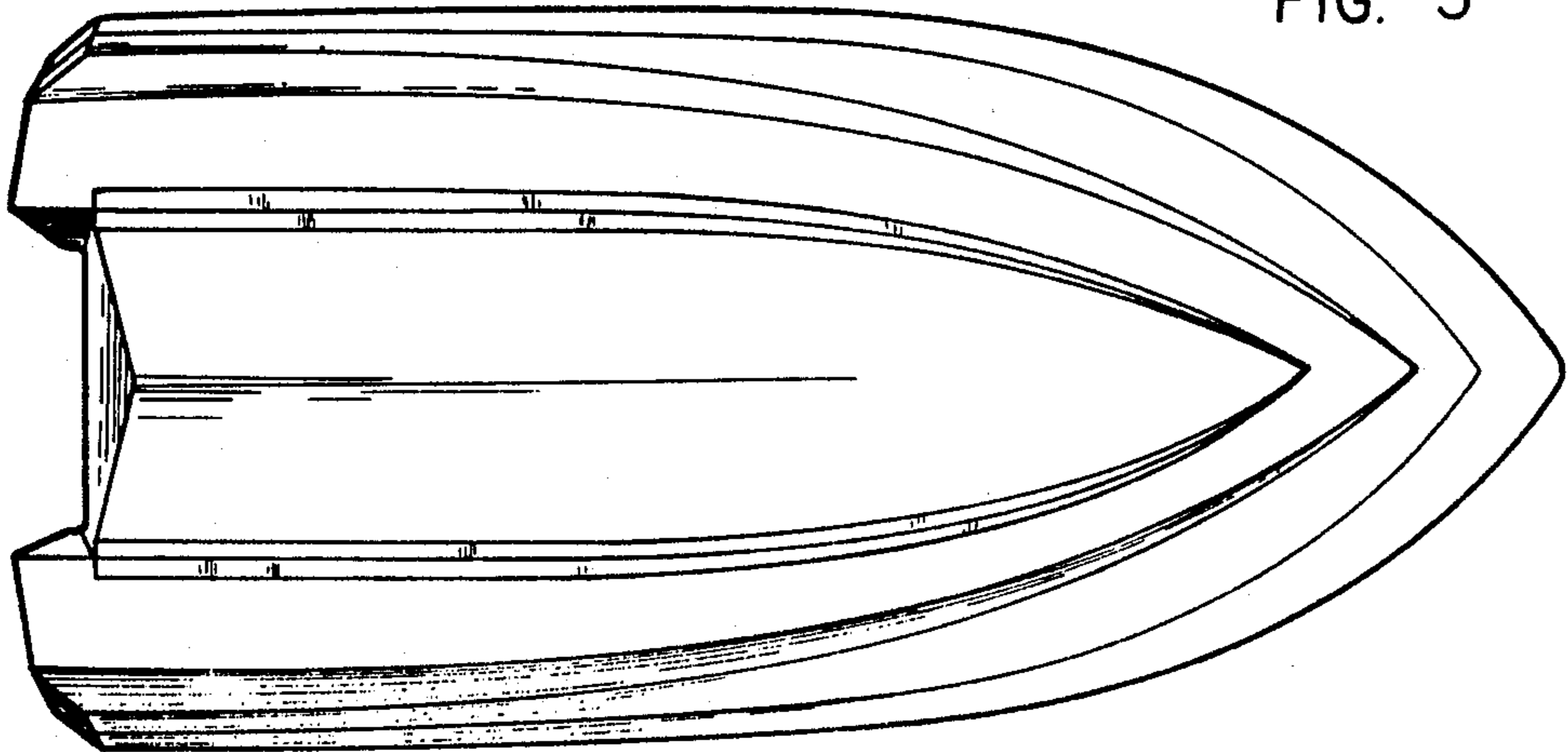

FIG. 5



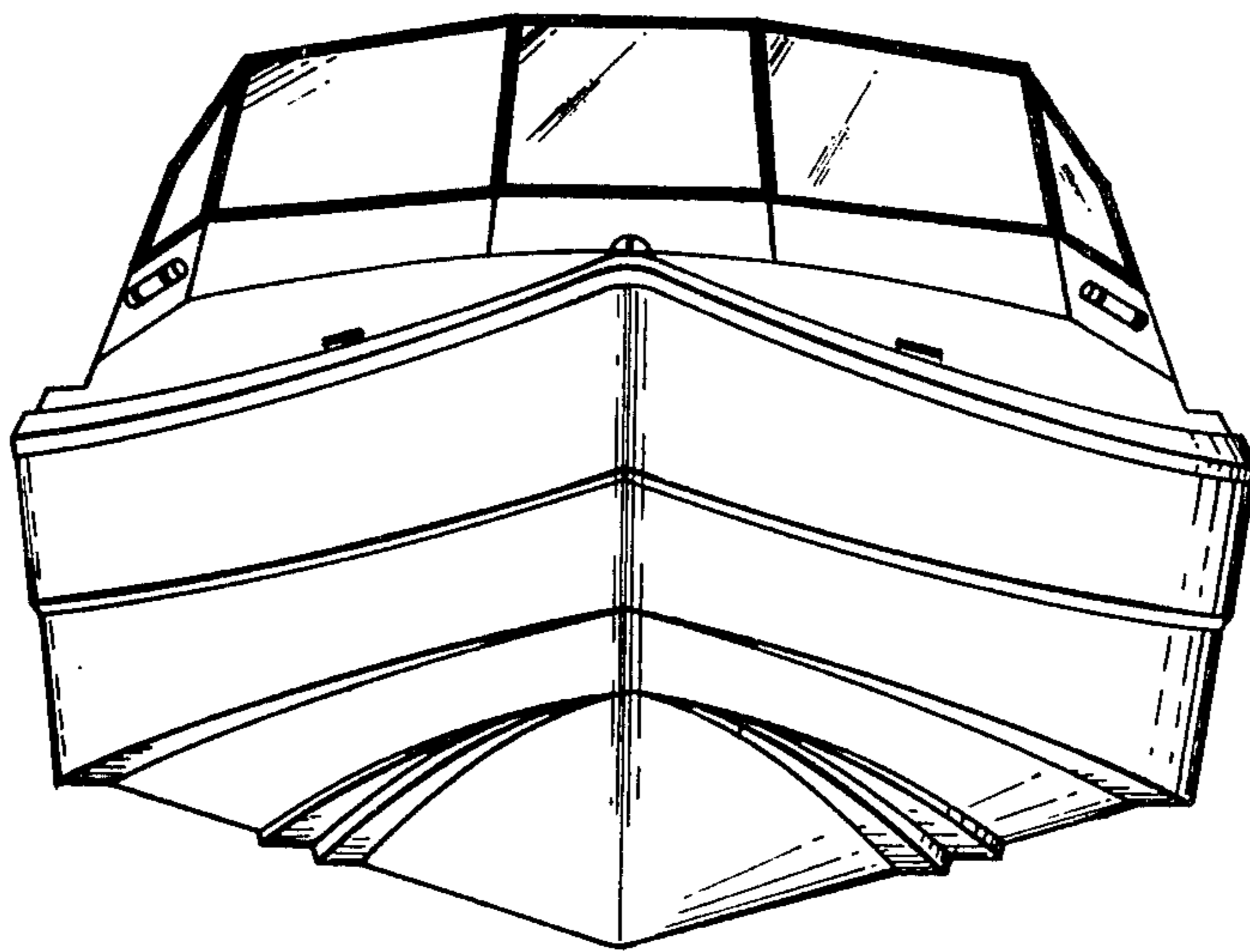

FIG. 6