

United States Patent [19]

Ito et al.

[11] Patent Number: **Des. 276,035**

[45] Date of Patent: **** Oct. 23, 1984**

[54] **MOTOR TRICYCLE**

[75] Inventors: **Jun Ito, Tokyo; Kazuhiko Yokoyama, Saitama, both of Japan**

[73] Assignee: **Honda Giken Kogyo Kabushiki Kaisha, Tokyo, Japan**

[**] Term: **14 Years**

[21] Appl. No.: **436,082**

[22] Filed: **Oct. 22, 1982**

[30] **Foreign Application Priority Data**

Jun. 24, 1982 [JP] Japan 57-28349

[52] U.S. Cl. **D12/110**

[58] Field of Search D12/110, 85; 180/210, 180/211, 215, 217

[56] **References Cited**

U.S. PATENT DOCUMENTS

D. 267,637 1/1983 Ohba D12/110

D. 267,792 2/1983 Ohba D12/110
D. 267,862 2/1983 Kimura et al. D12/110
D. 268,660 4/1983 Ohba D12/110
D. 269,261 6/1983 Mikado D12/110

Primary Examiner—James M. Gandy
Attorney, Agent, or Firm—Sughrue, Mion, Zinn, Macpeak and Seas

[57] **CLAIM**

The ornamental design for a motor tricycle, as shown and described.

DESCRIPTION

FIG. 1 is a front and right side perspective view of a motor tricycle showing our new design; FIG. 2 is a front elevational view thereof; FIG. 3 is a rear elevational view thereof; FIG. 4 is a top plan view thereof; FIG. 5 is a bottom plan view thereof; FIG. 6 is a right side elevational view thereof; and FIG. 7 is a left side perspective view thereof.

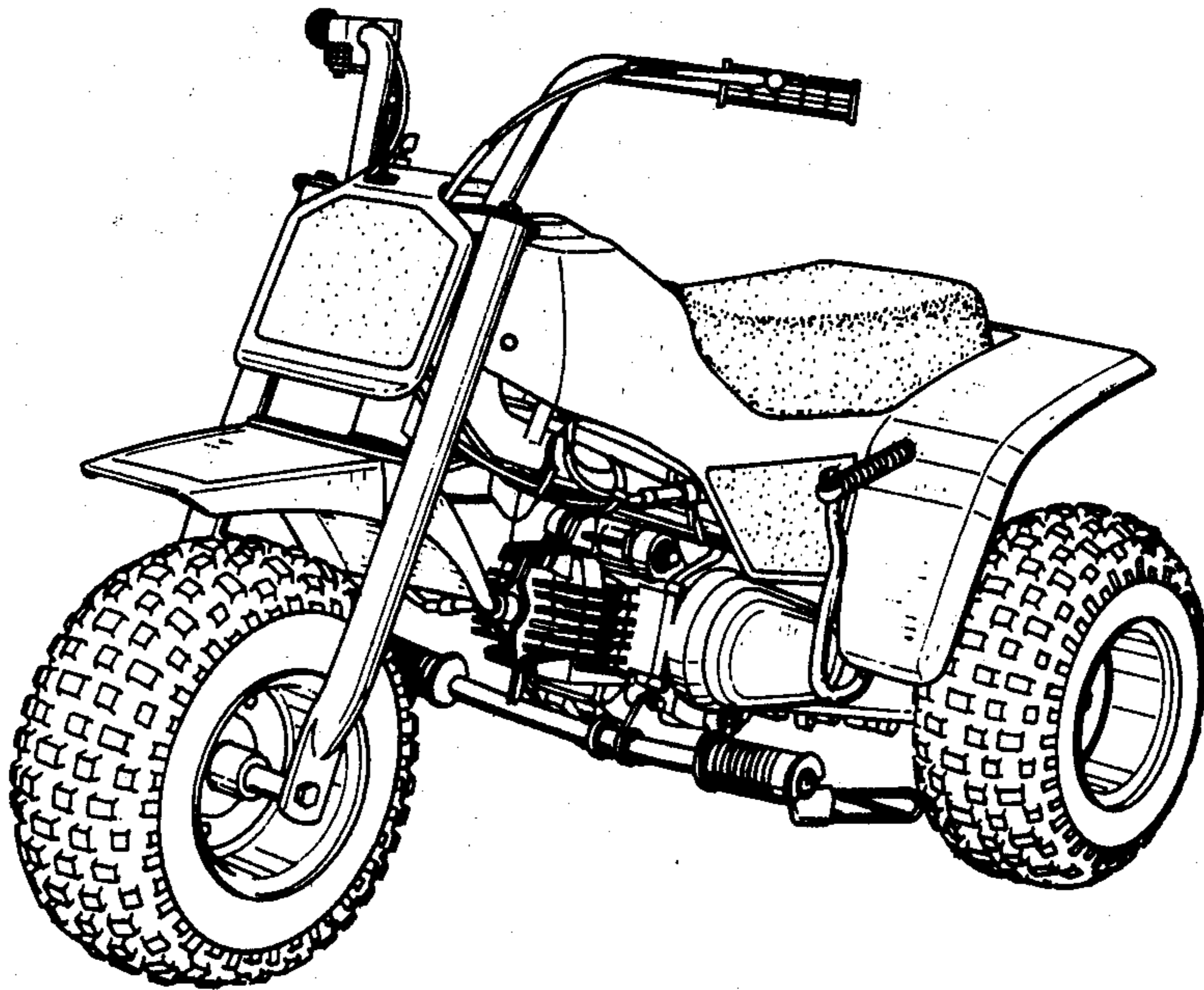

Fig. 1

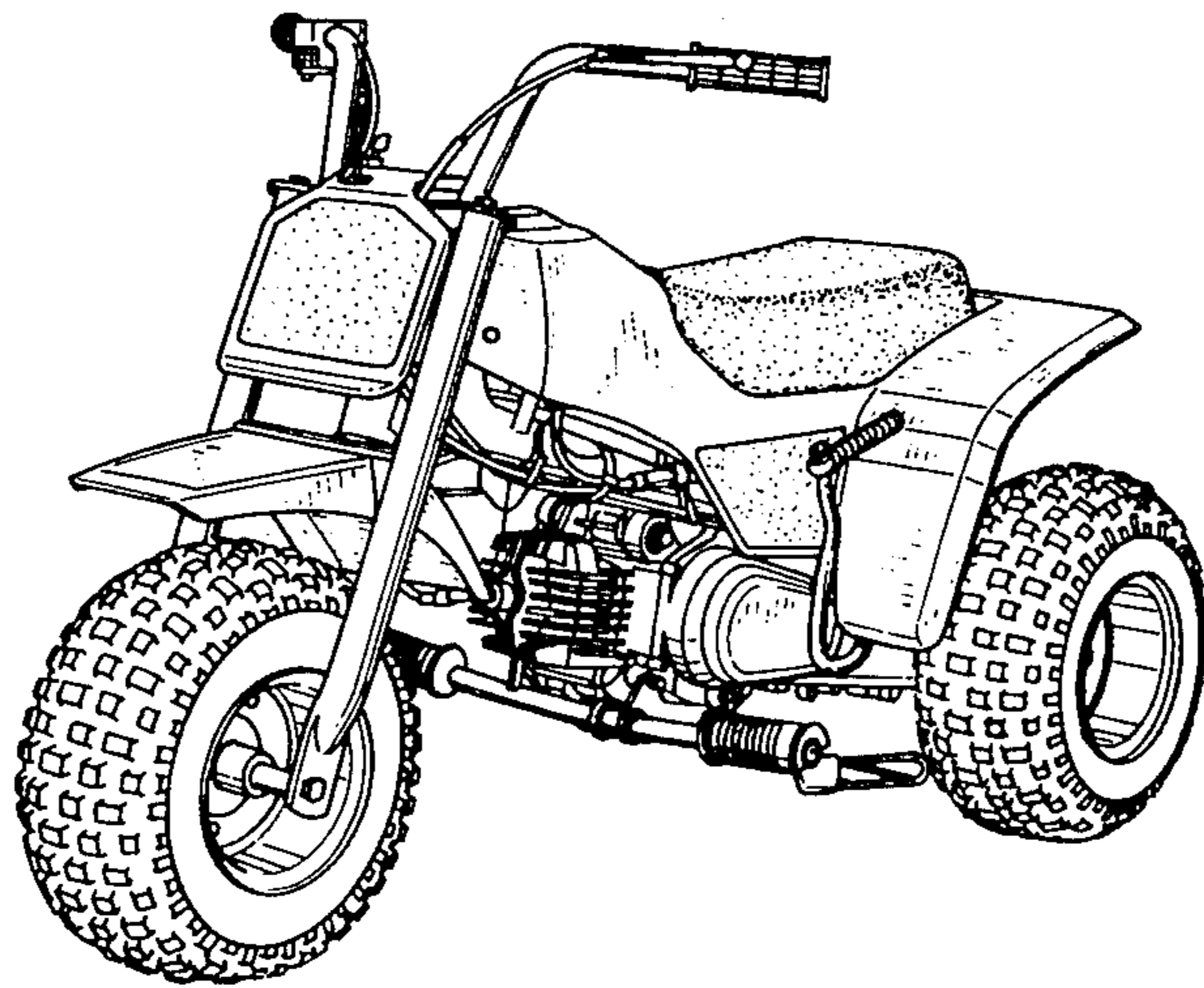

Fig. 2

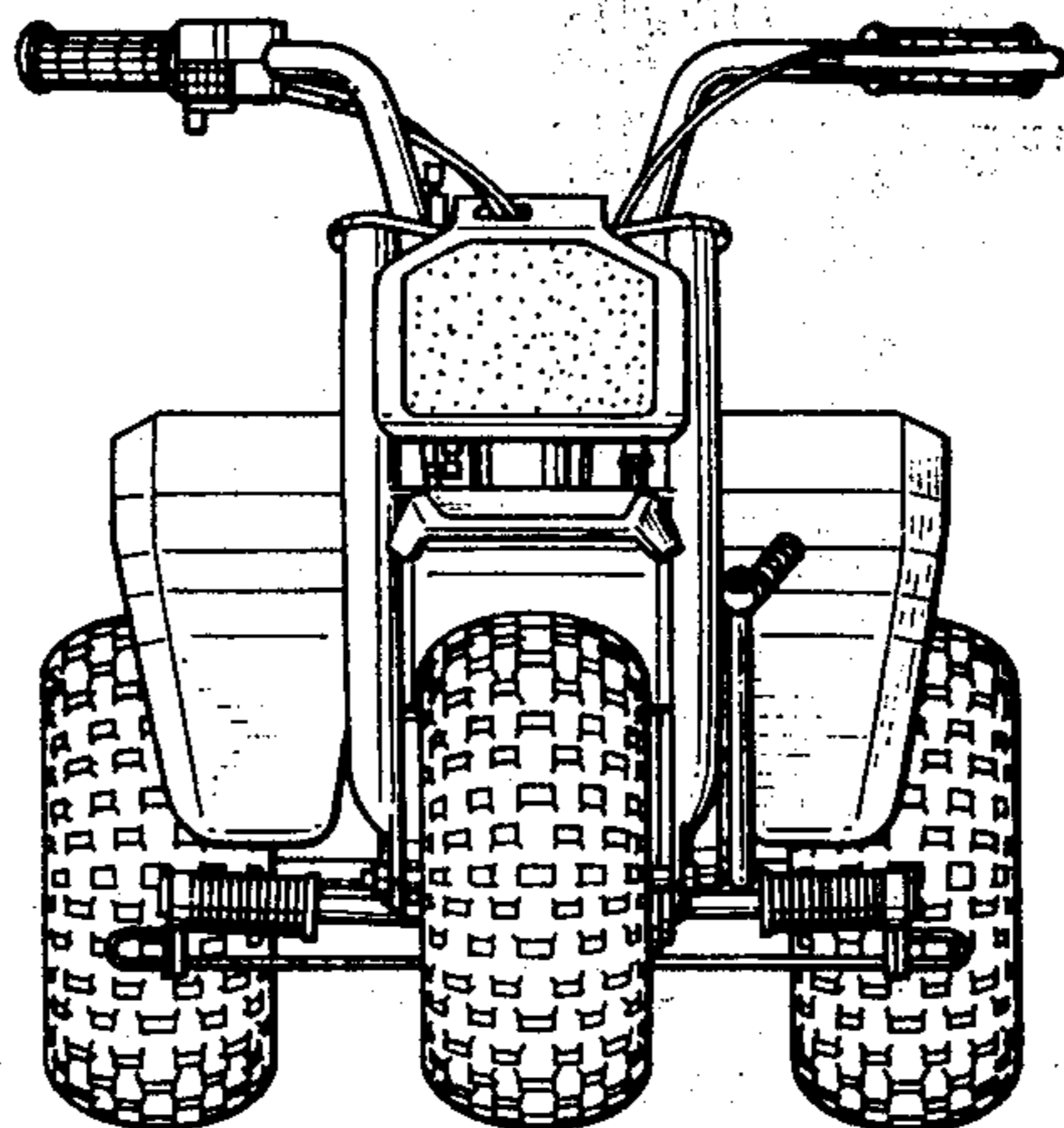

Fig. 3

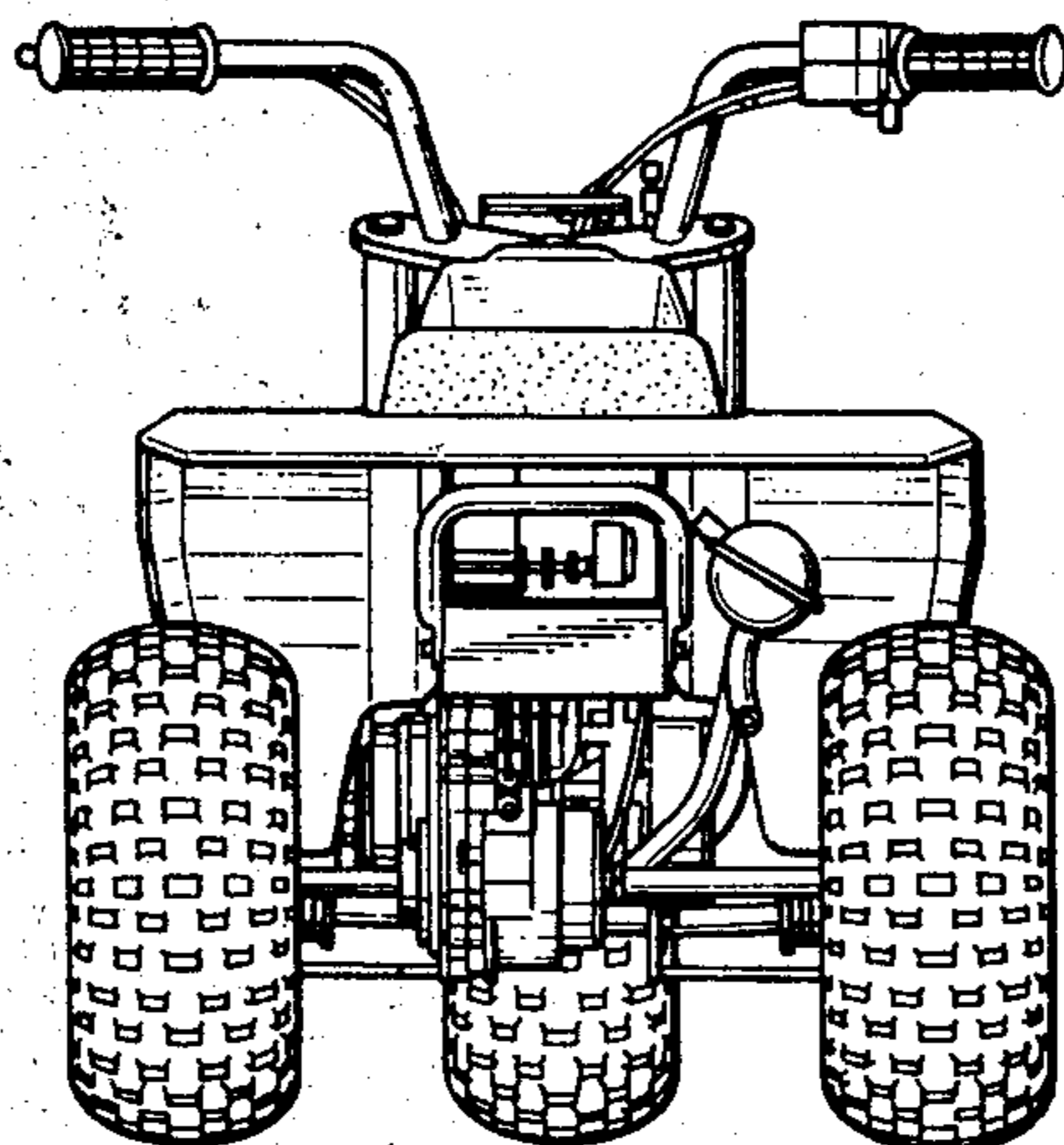

Fig. 4

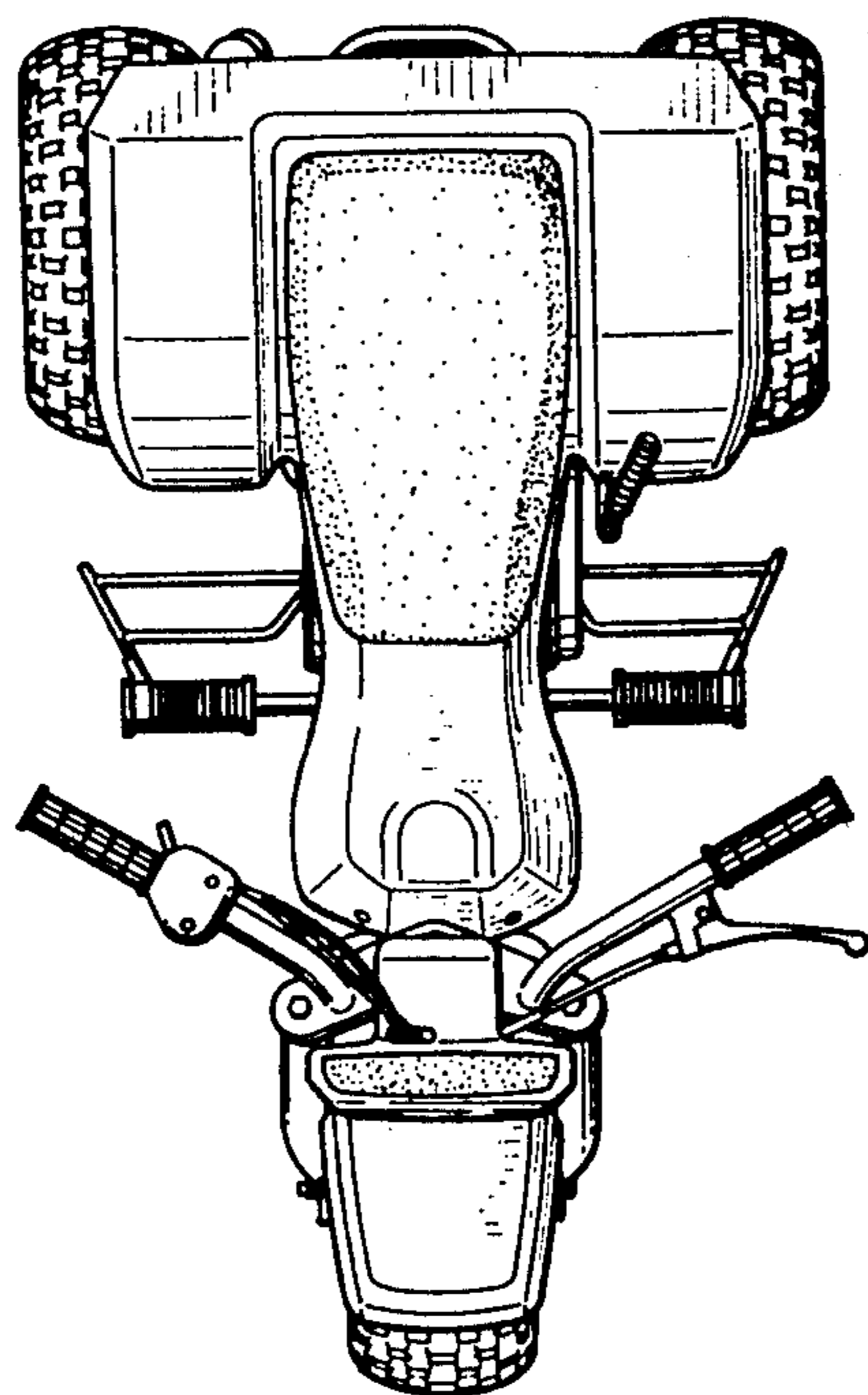

Fig. 5

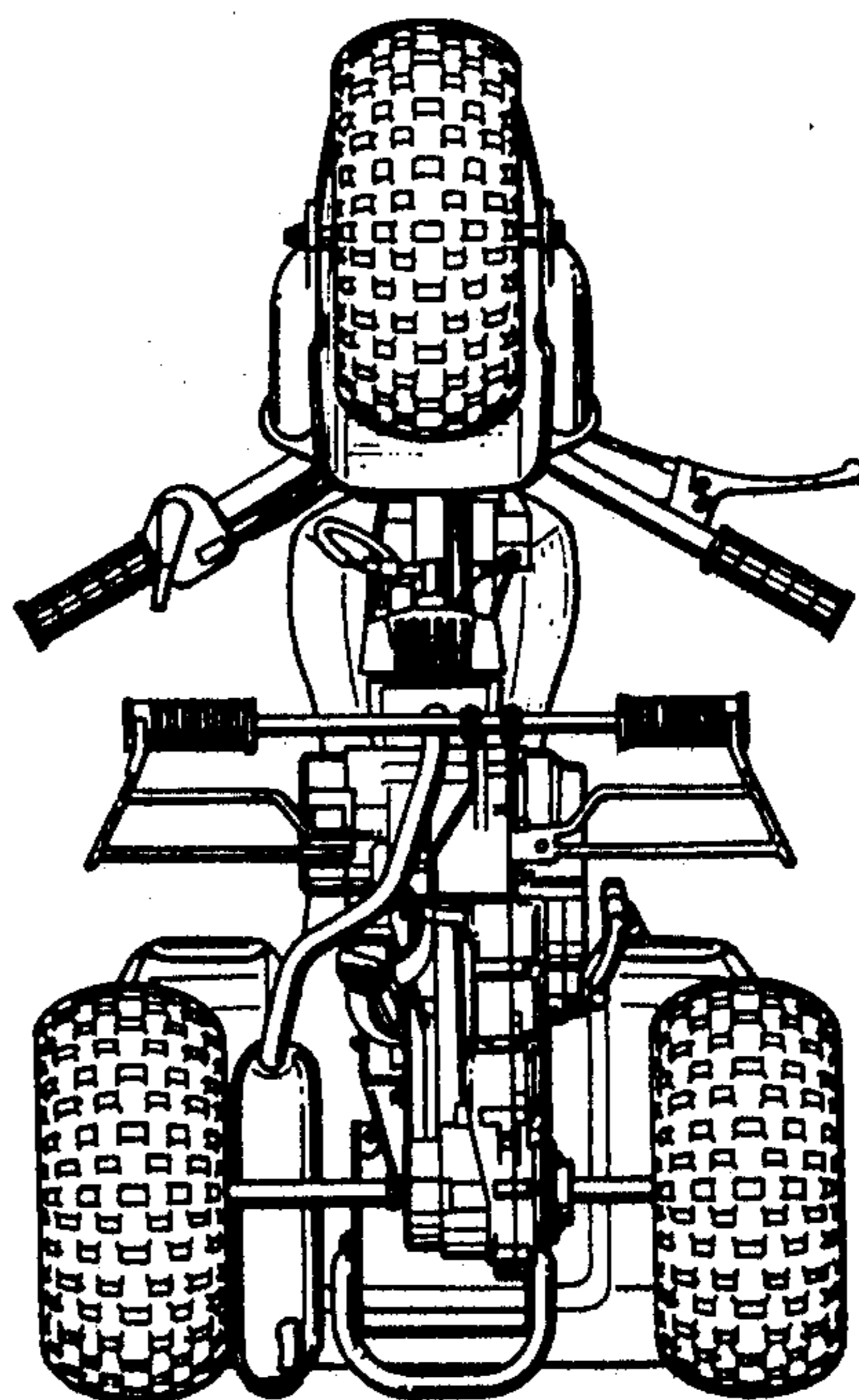

Fig. 6

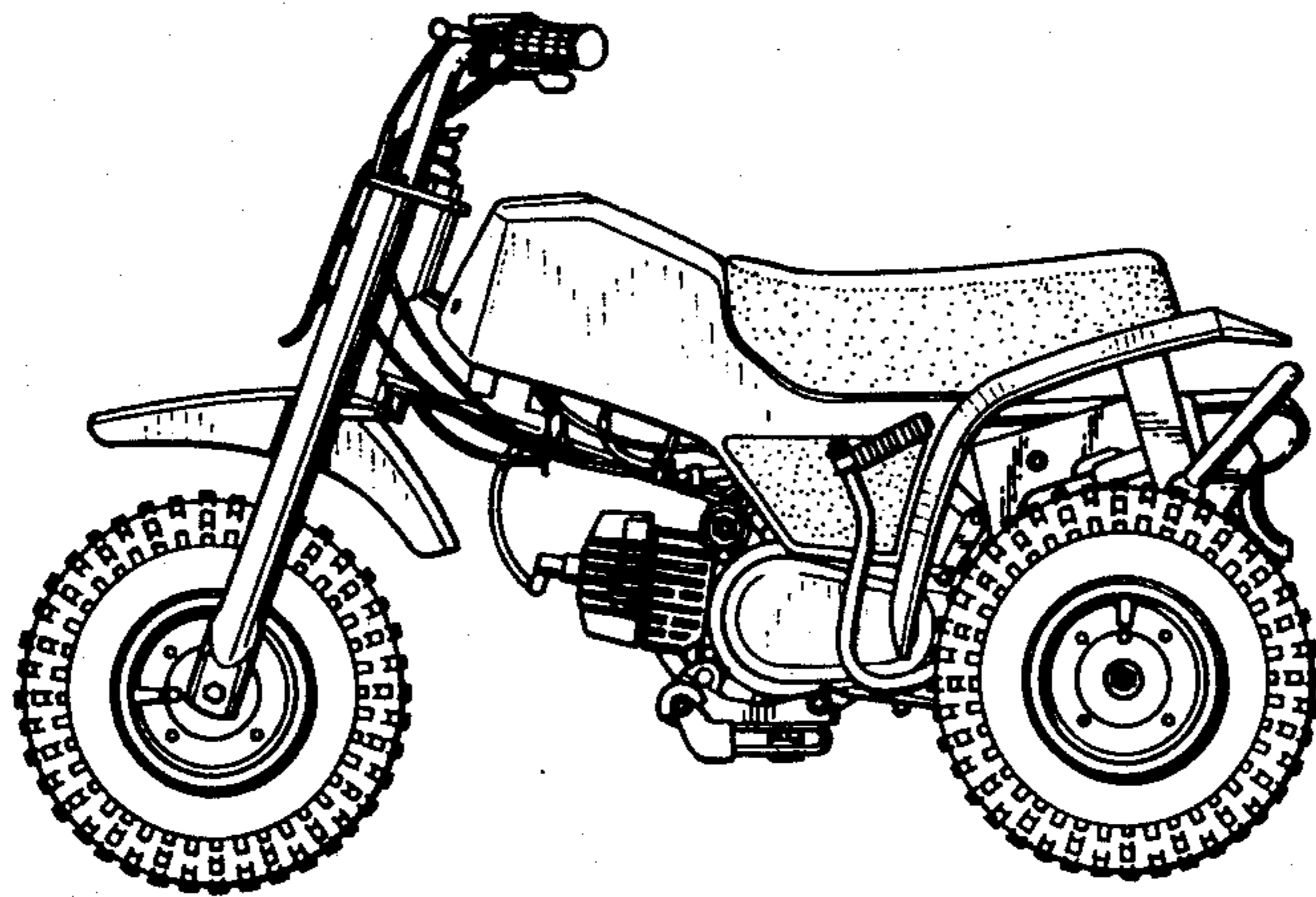

Fig. 7

