

[54] MOTOR TRICYCLE

[75] Inventors: Yasuhiro Ohba; Mituru Yamamoto, both of Saitama, Japan

[73] Assignee: Honda Giken Kogyo Kabushiki Kaisha, Tokyo, Japan

[**] Term: 14 Years

[21] Appl. No.: 401,690

[22] Filed: Jul. 26, 1982

[30] Foreign Application Priority Data

Feb. 5, 1982 [JP] Japan 57-4681
[52] U.S. Cl. D12/110
[58] Field of Search D12/110, 85; 180/210, 180/211, 215, 217

[56] References Cited

U.S. PATENT DOCUMENTS

D. 267,637 1/1983 Ohba D12/110

D. 267,792 2/1983 Ohba D12/110
D. 267,862 2/1983 Kimura et al. D12/110
D. 268,660 4/1983 Ohba D12/110
D. 269,261 6/1983 Mikado D12/110

Primary Examiner—James M. Gandy
Attorney, Agent, or Firm—Sughrue, Mion, Zinn, Macpeak and Seas

[57] CLAIM

The ornamental design for a motor tricycle, as shown and described.

DESCRIPTION

FIG. 1 is a front and right side perspective view of a motor tricycle showing our new design; FIG. 2 is a front elevational view thereof; FIG. 3 is a rear elevational view thereof; FIG. 4 is a top plan view thereof; FIG. 5 is a bottom plan view thereof; FIG. 6 is a right side elevational view thereof; and FIG. 7 is a left side elevational view thereof.

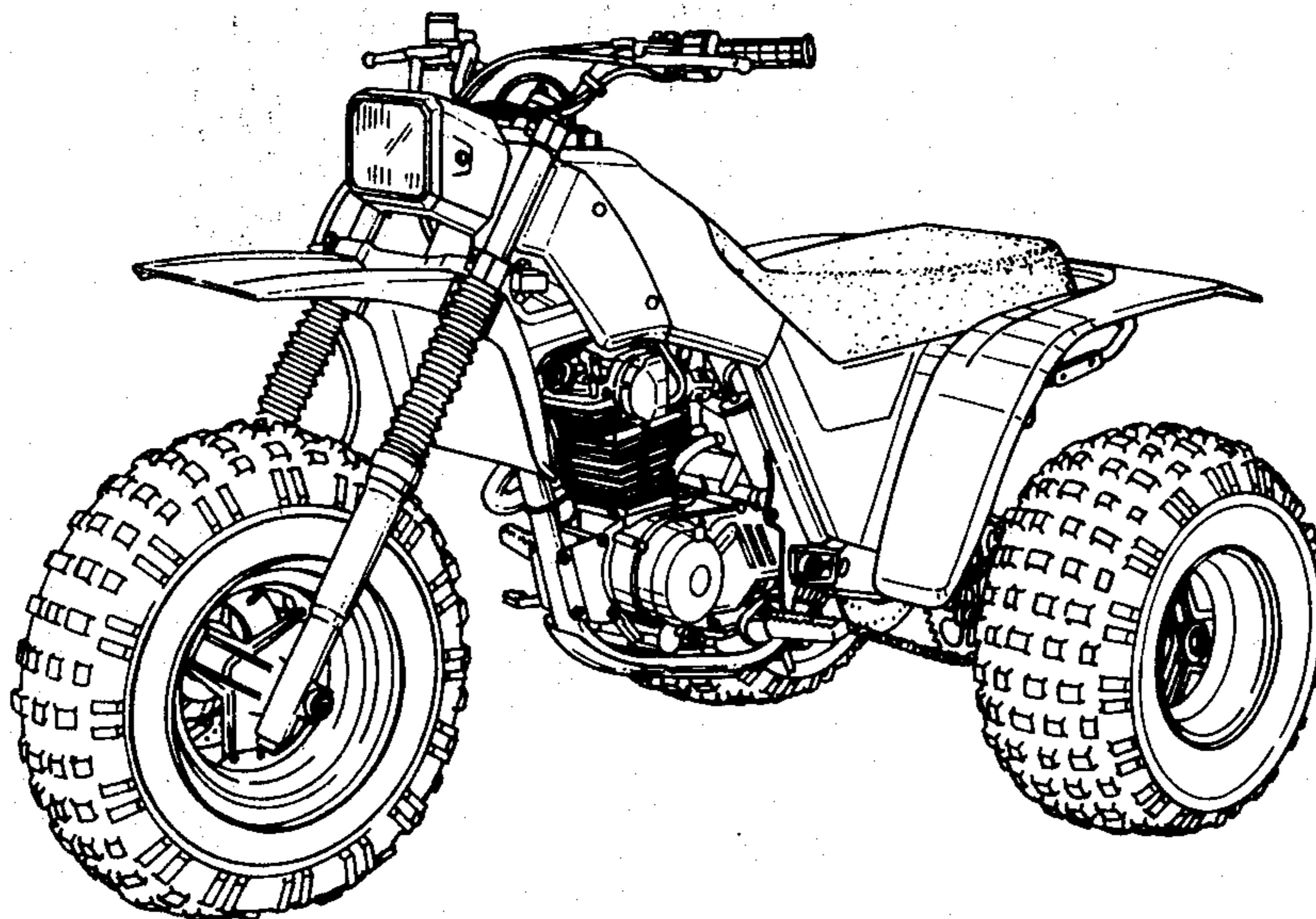

Fig. 1

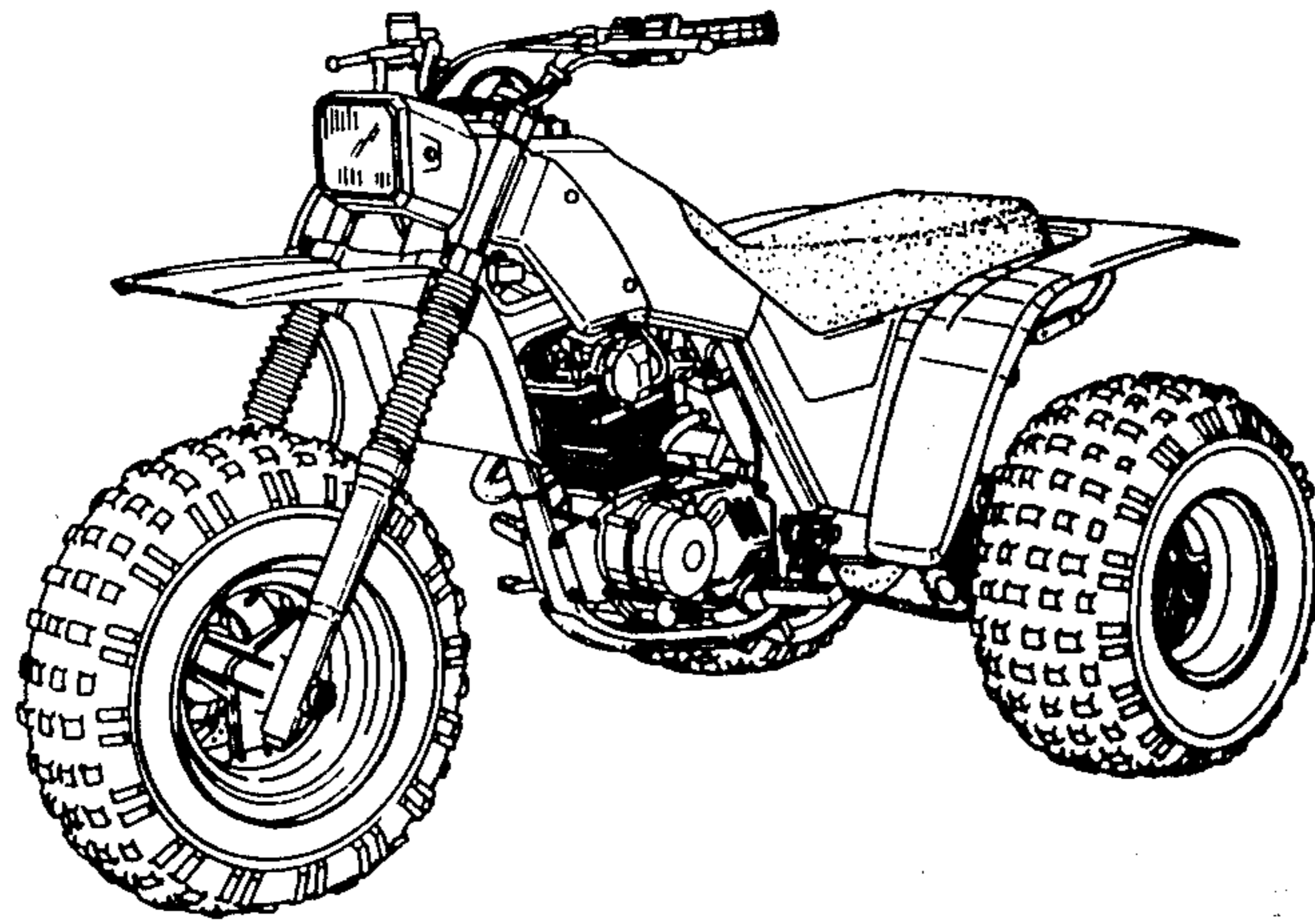

Fig. 2

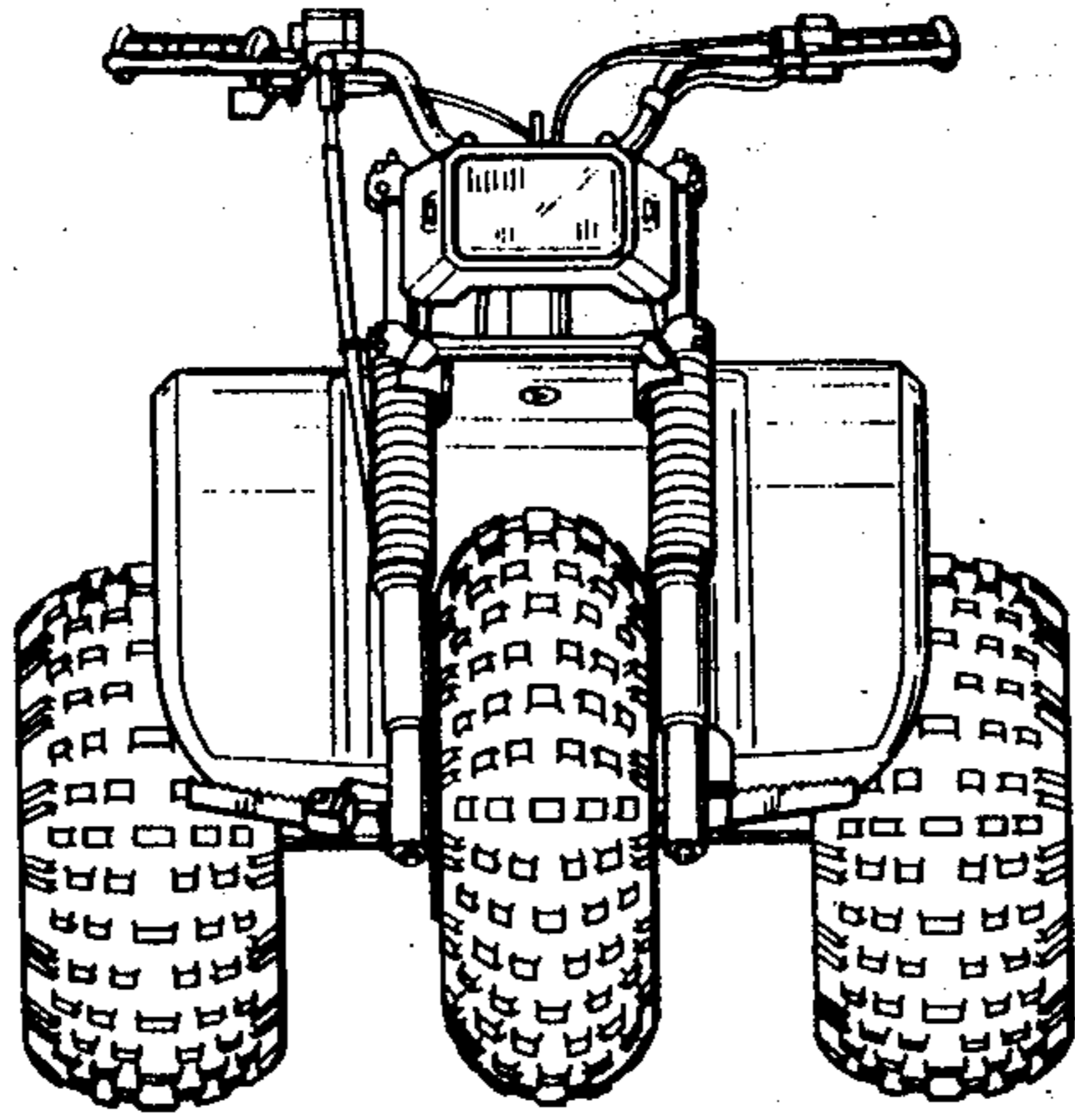

Fig. 3

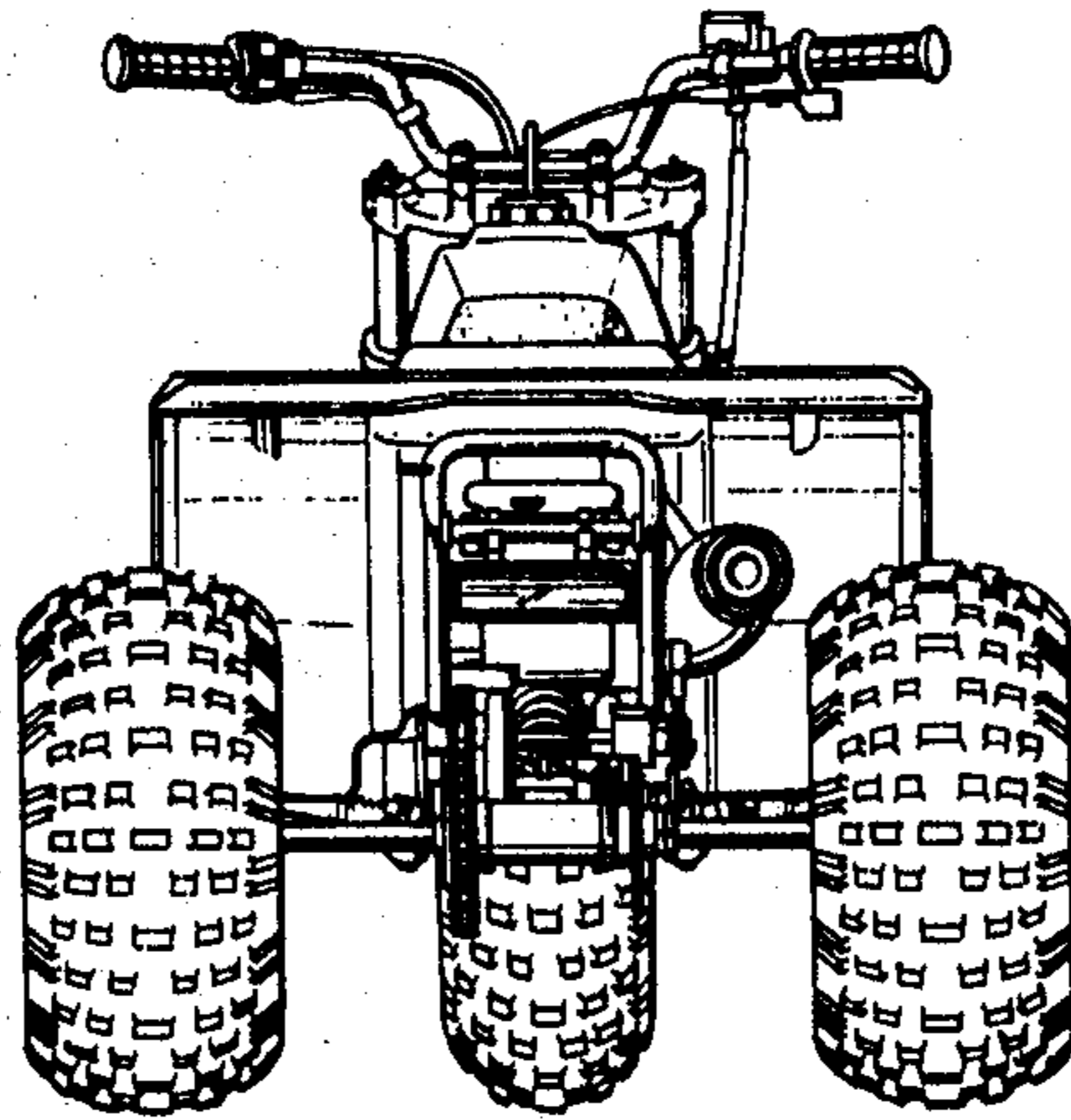

Fig. 4

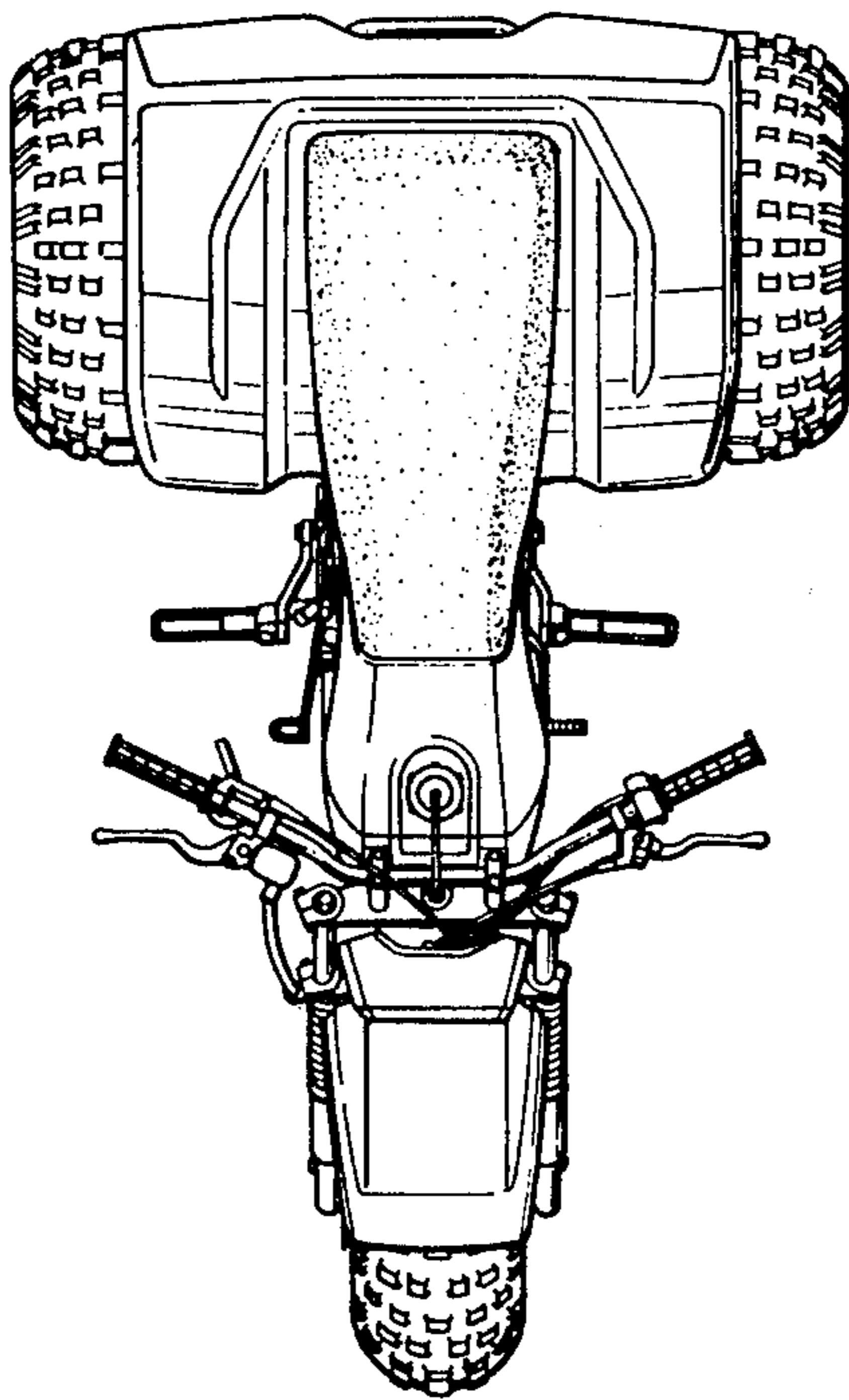

Fig. 5

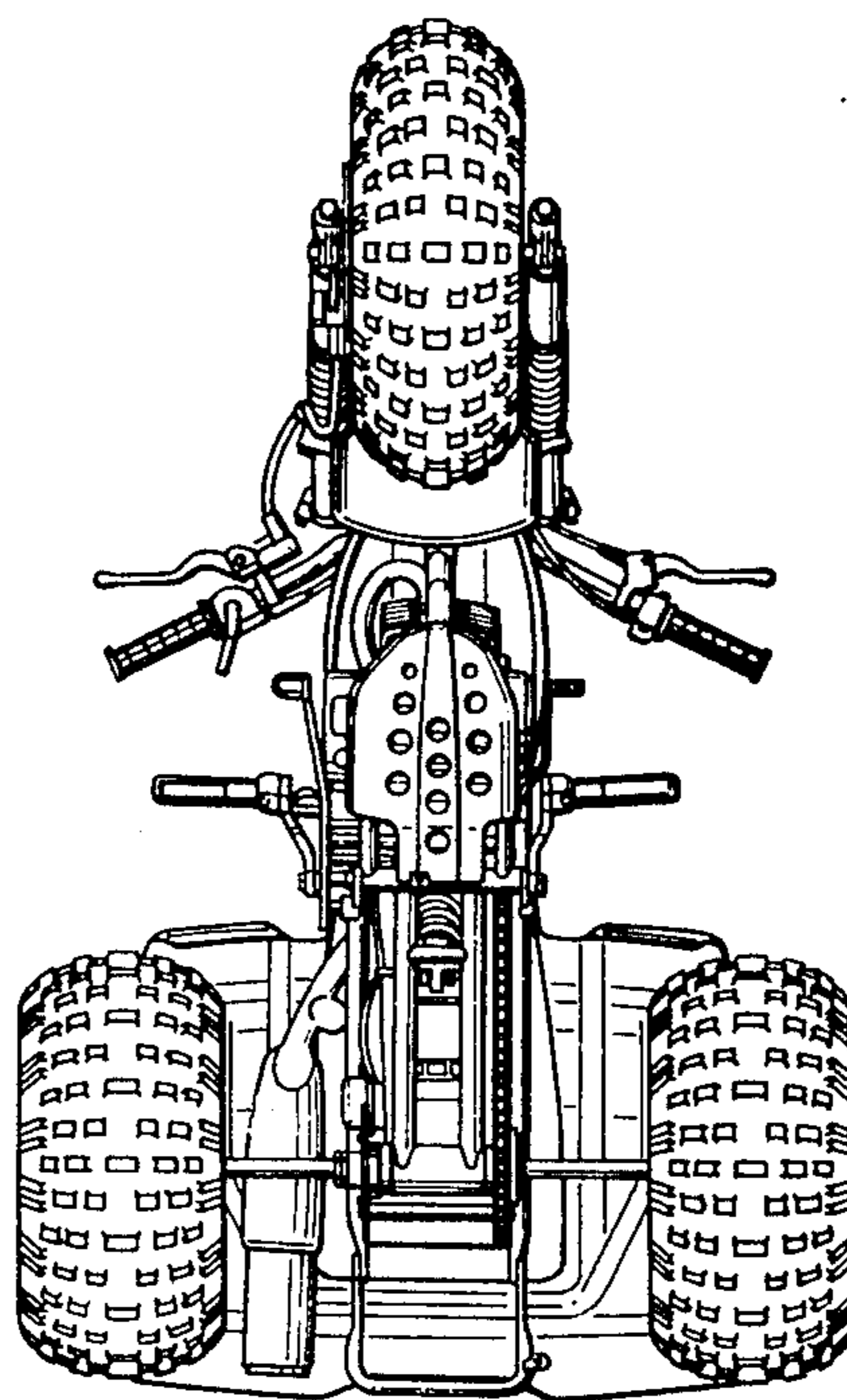

Fig. 6

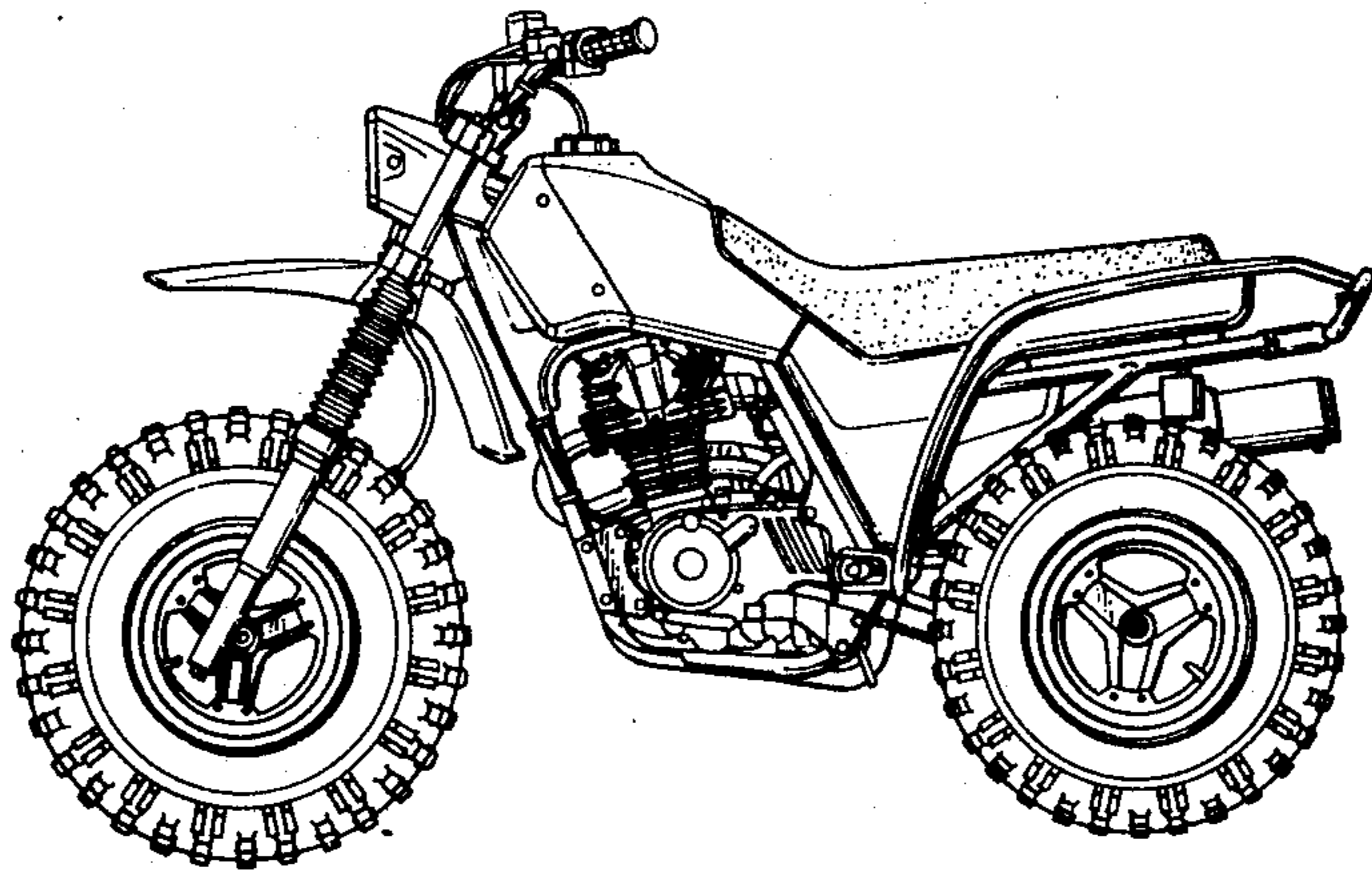

Fig. 7

