

# United States Patent [19]

Lozelle et al.

[11] Patent Number: **Des. 276,032**

[45] Date of Patent: **\*\* Oct. 23, 1984**

[54] **CRANE RAIL CLIP**

[76] Inventors: **James R. Lozelle**, 13 Regent Dr., Ann Arbor, Mich. 48104; **William E. Lozelle**, 1193 Sunningdale, Grosse Pointe Woods, Mich. 48236

[\*\*] Term: **14 Years**

[21] Appl. No.: **335,960**

[22] Filed: **Dec. 28, 1981**

[52] U.S. Cl. .... **D12/51**

[58] Field of Search ..... **D15/11, 28; D12/51; 238/338, 349, 310**

[56] **References Cited**

**U.S. PATENT DOCUMENTS**

948,375	2/1910	Knox	238/338
1,315,132	9/1919	Knox	238/338
1,571,008	1/1926	Hilpert	238/338
1,657,240	1/1928	Dalton	238/338
2,167,870	8/1939	Boyce	238/338

4,193,544	3/1980	Marchant et al.	238/338
4,289,059	9/1981	Alderton	238/338

*Primary Examiner*—Wallace R. Burke  
*Assistant Examiner*—Suzanne N. Gitlin  
*Attorney, Agent, or Firm*—Stephenson and Boller

[57] **CLAIM**

The ornamental design for a crane rail clip, as shown and described.

**DESCRIPTION**

FIG. 1 is an enlarged top perspective view of a crane rail clip showing our new design;  
FIG. 2 is a bottom perspective view thereof;  
FIG. 3 is a front elevational view thereof;  
FIG. 4 is a side elevational view taken from the left of FIG. 1;  
FIG. 5 is a bottom plan view thereof;  
FIG. 6 is a top plan view thereof;  
FIG. 7 is a side elevational view taken from the right of FIG. 1;  
FIG. 8 is a rear elevational view thereof.

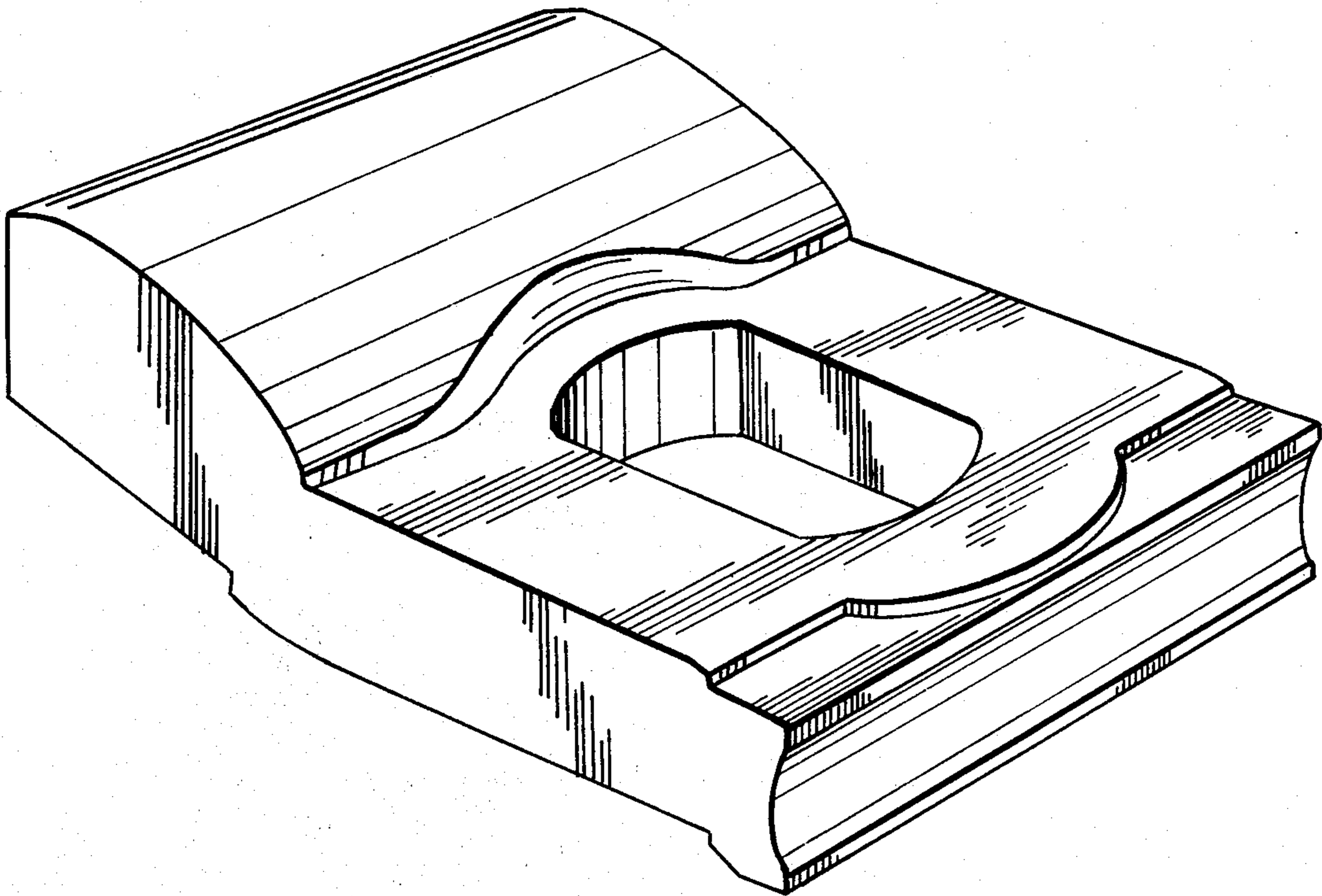

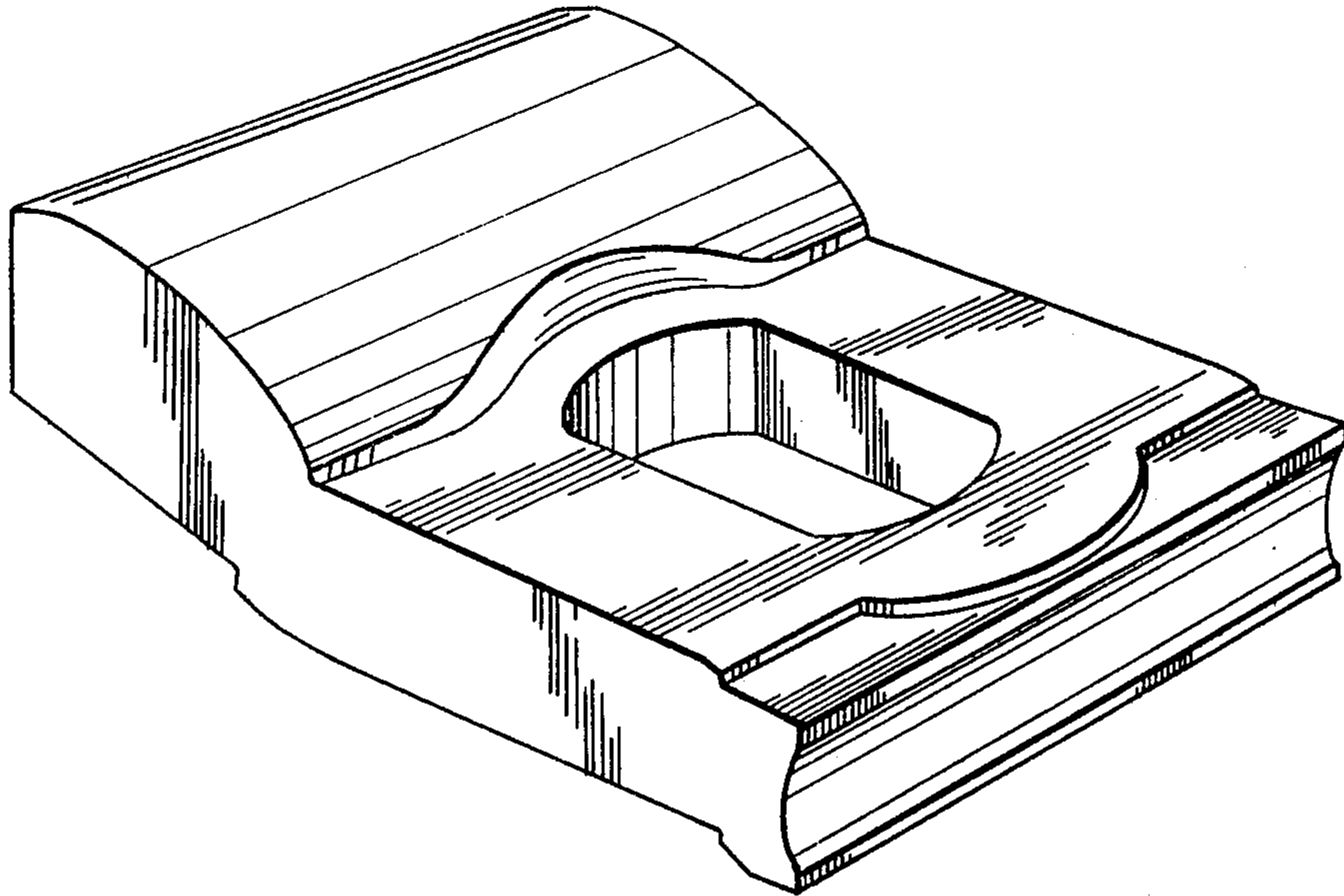

Fig. 1

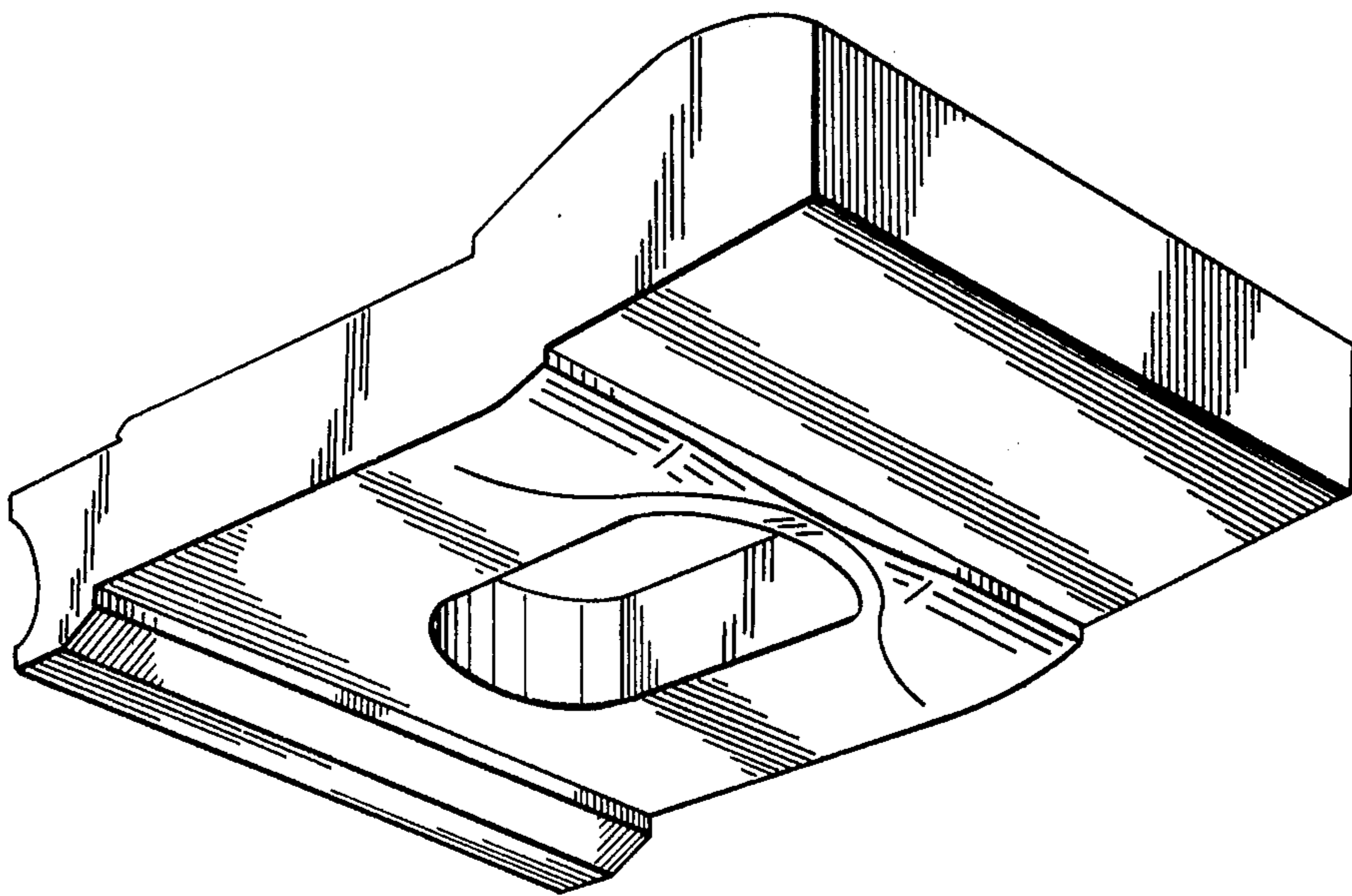

Fig. 2

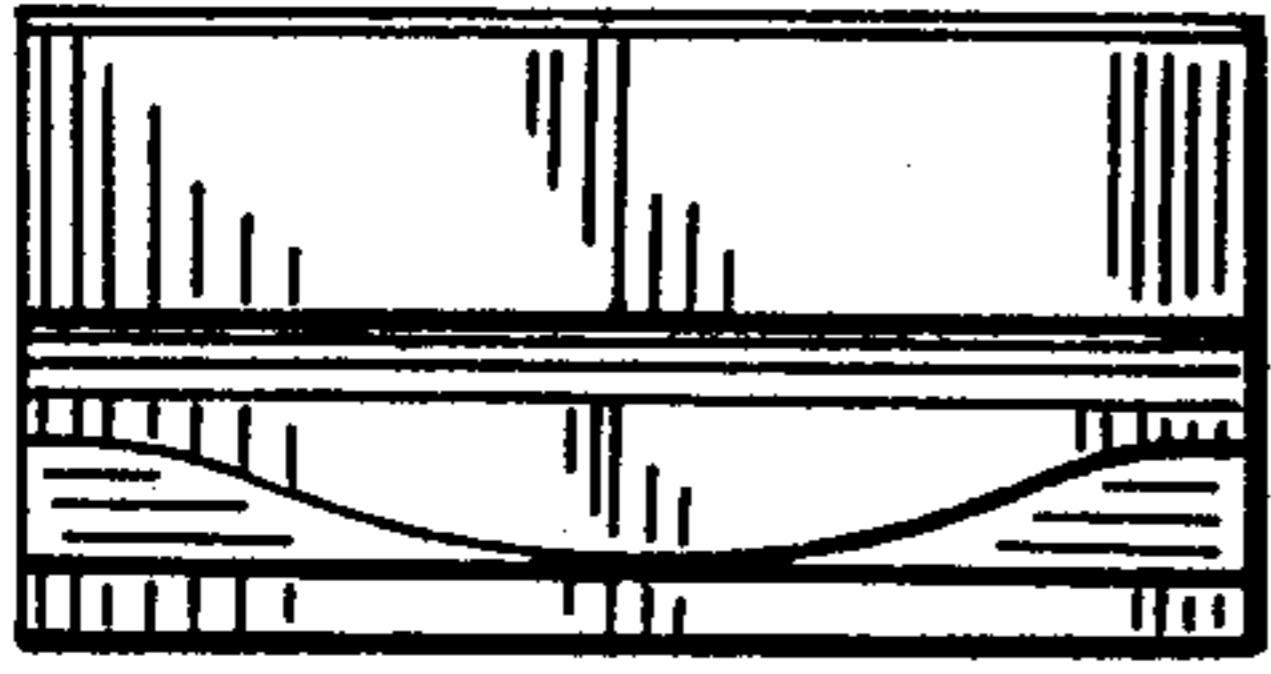

Fig. 3

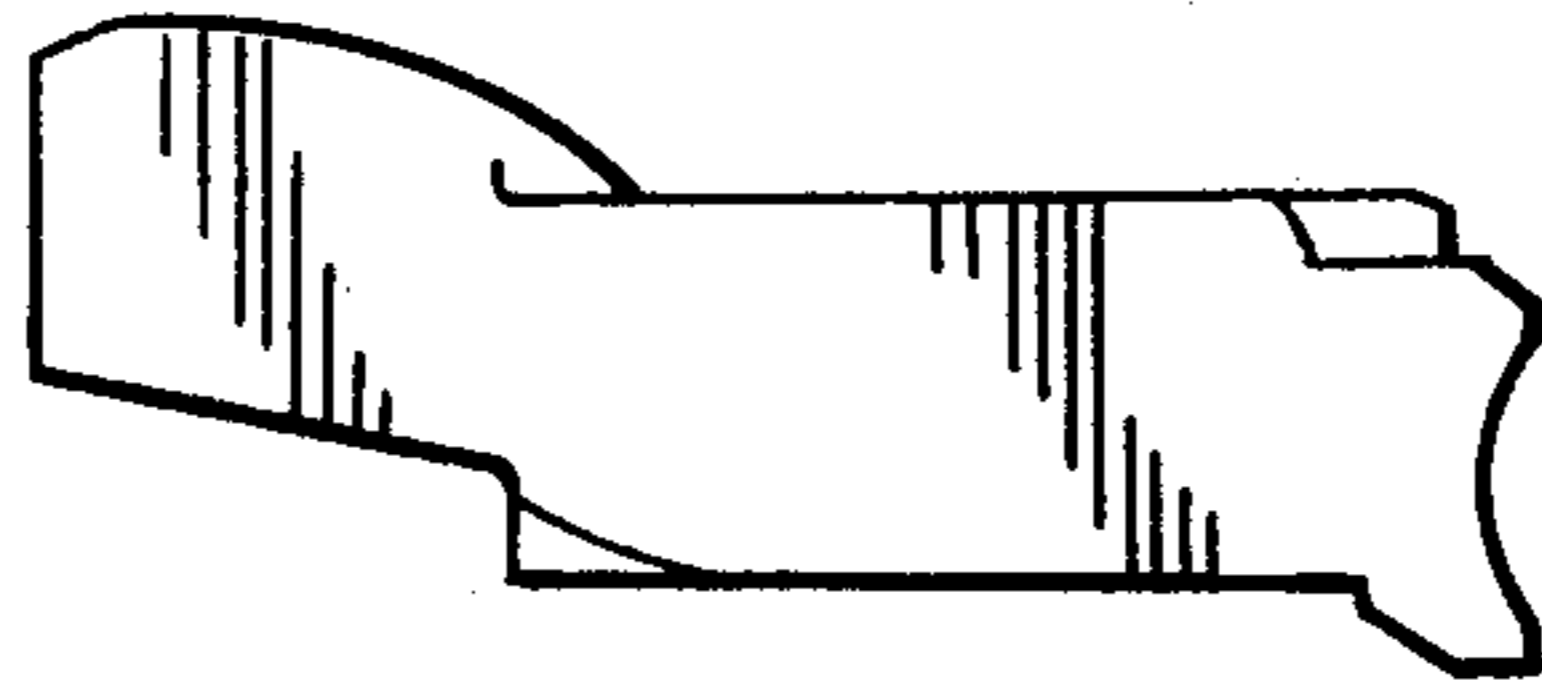

Fig. 4

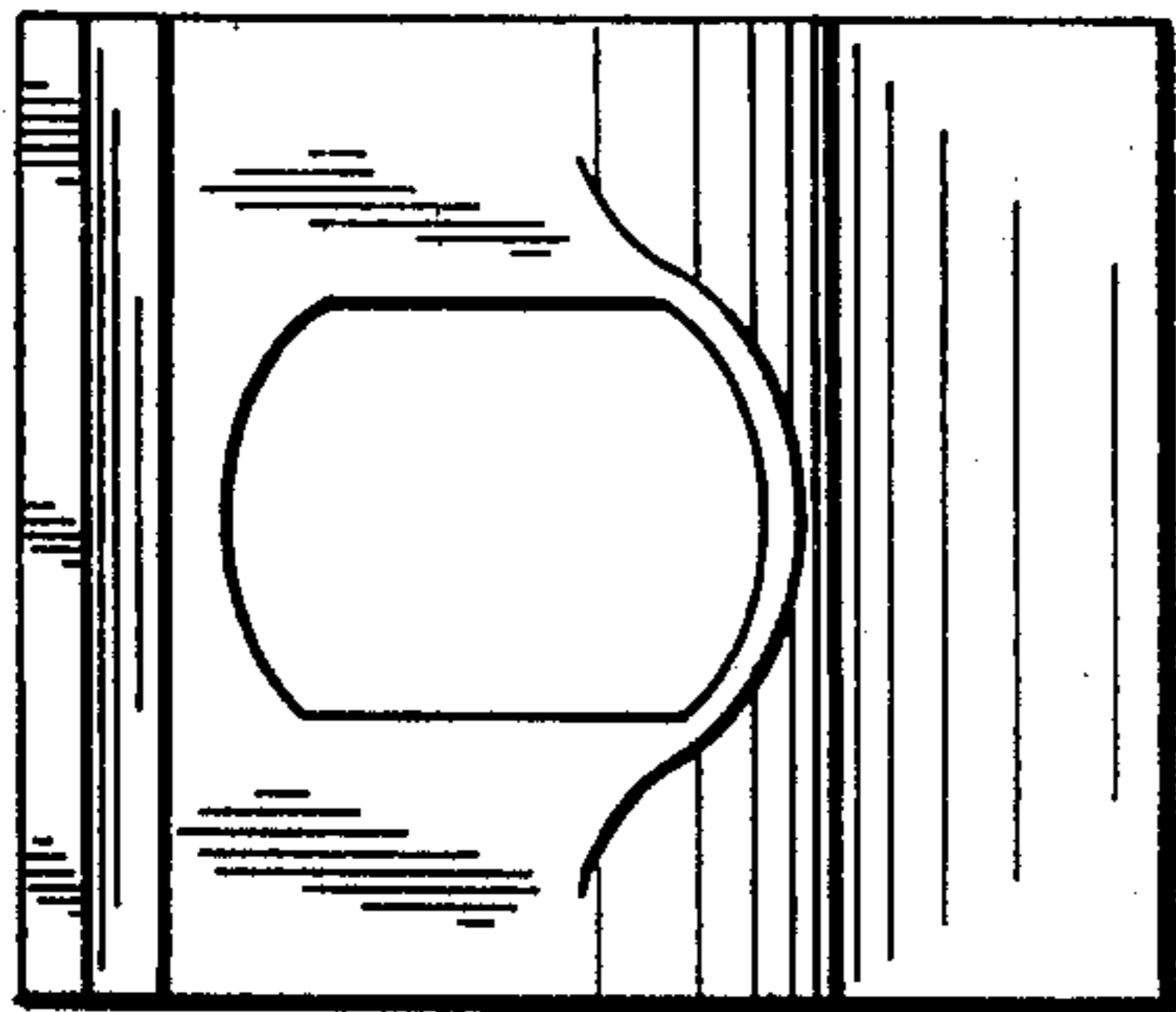

Fig. 5

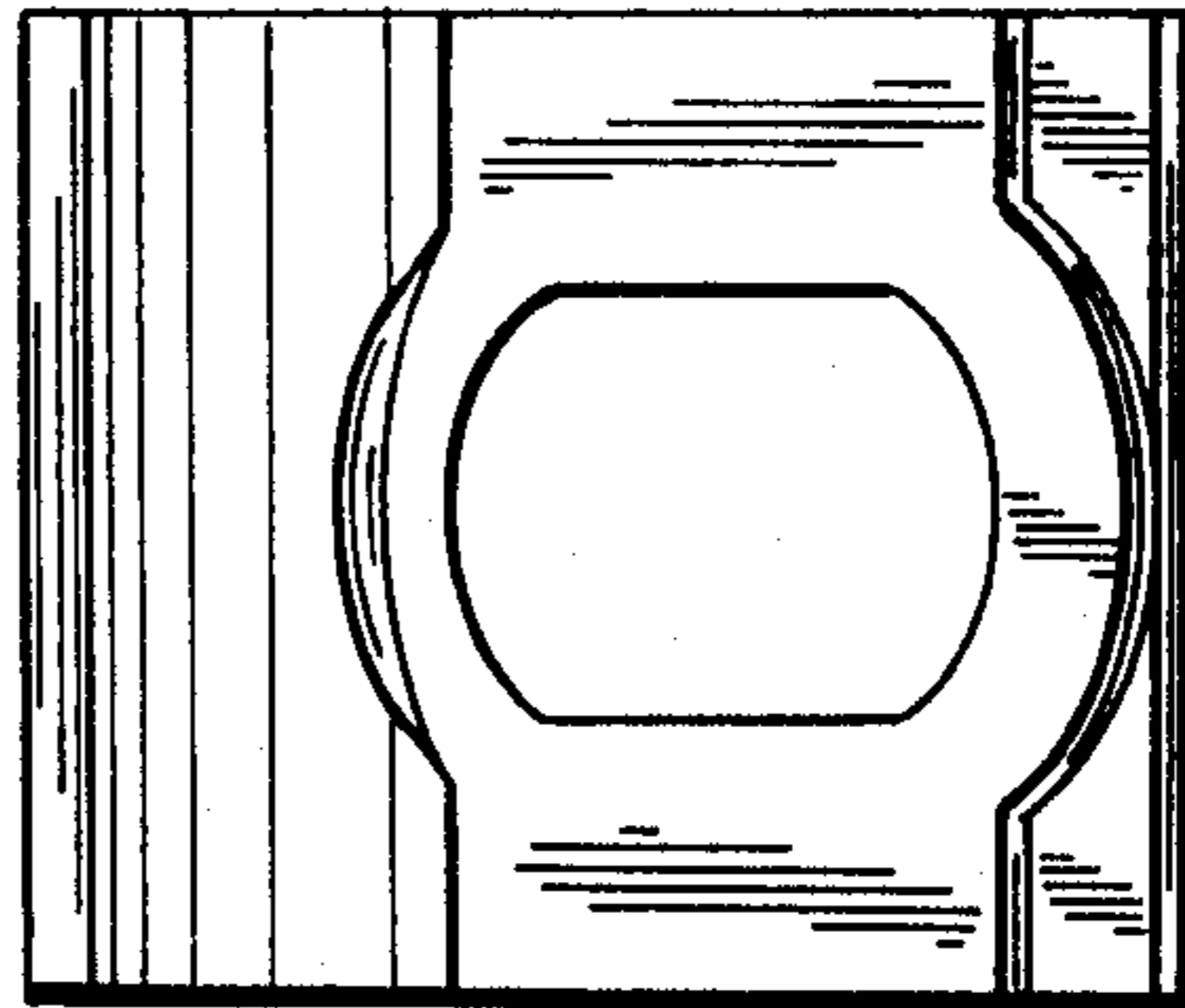

Fig. 6

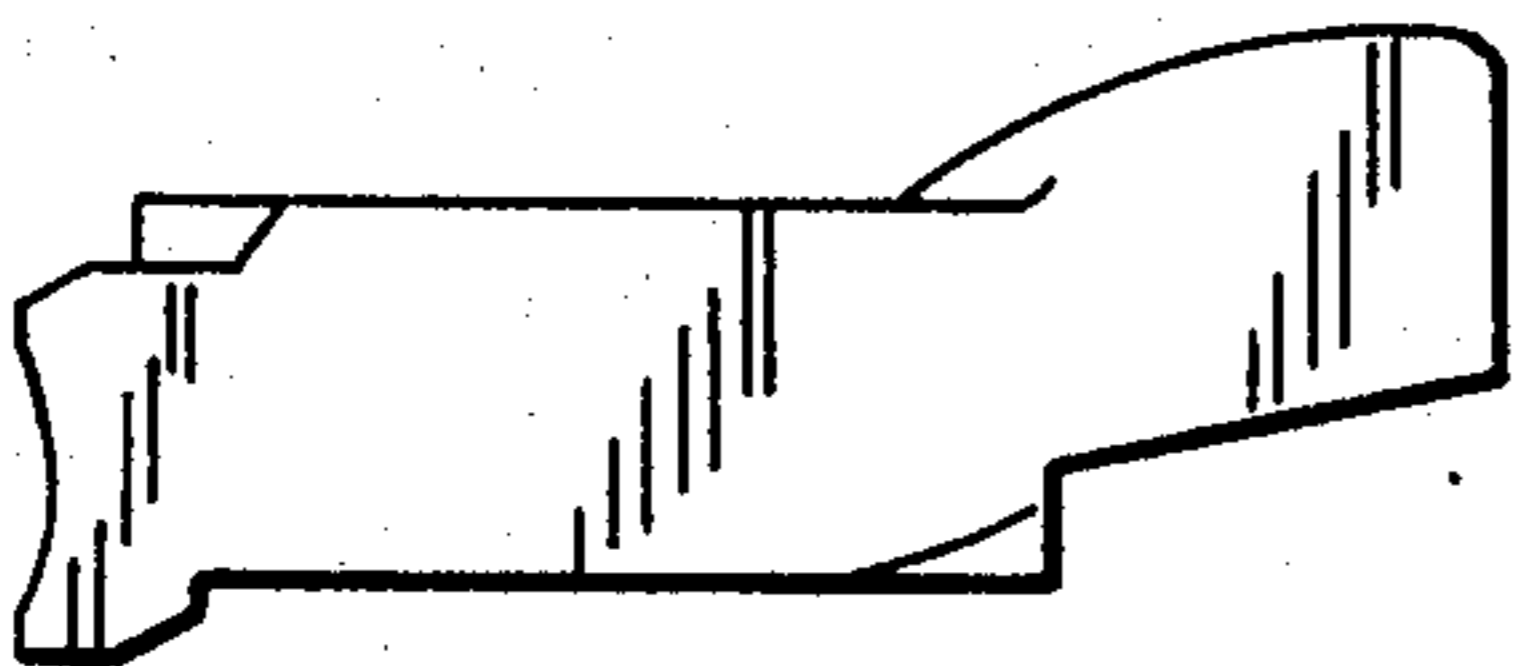

Fig. 7

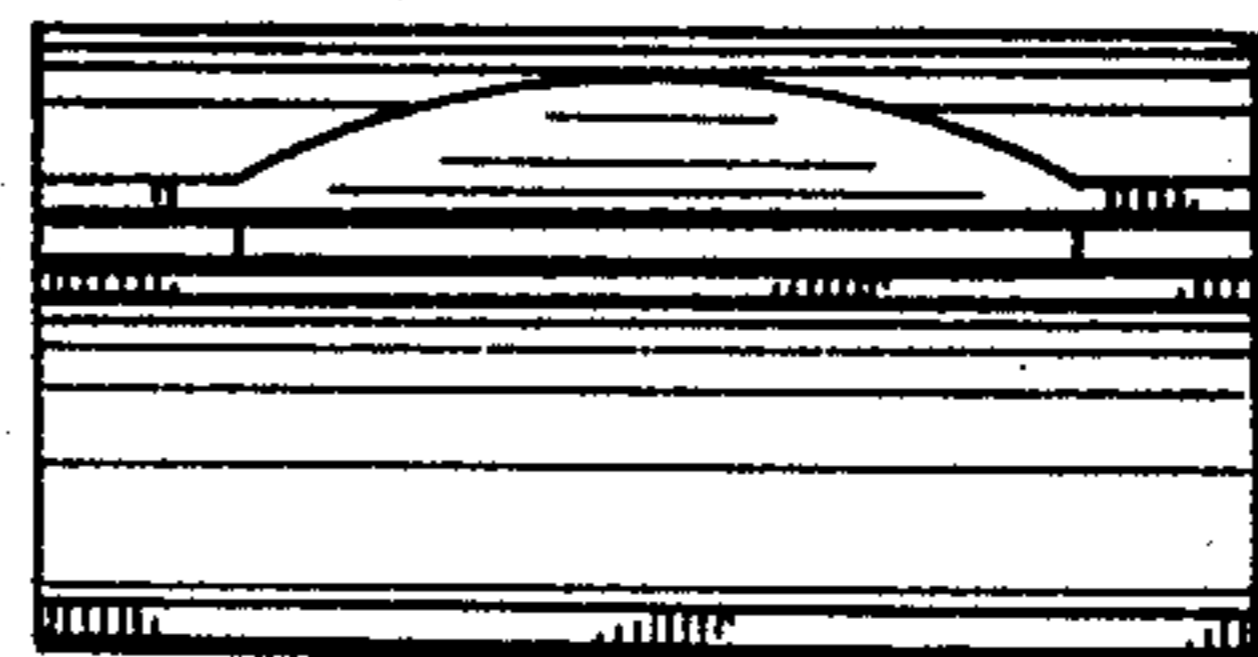

Fig. 8