

[54] TOY VEHICLE

[75] Inventors: Peter Manning, Tiverton, England; Melvin Mednick, New City, N.Y.

[73] Assignee: LJN Toys, Ltd., New York, N.Y.

[\*\*] Term: 14 Years

[21] Appl. No.: 411,836

[22] Filed: Aug. 26, 1982

[52] U.S. Cl. .... D21/134

[58] Field of Search ..... D21/73, 76, 78, 79, D21/80, 128, 132, 134, 135, 136, 137, 140; 46/201, 210, 222, 223; D12/93, 99, 86

[56] References Cited

U.S. PATENT DOCUMENTS

- D. 220,837 6/1971 Mattson ..... D12/86
- D. 226,121 1/1973 Gilford et al. .... D21/135
- D. 253,193 10/1979 Pauly et al. .... D21/136

OTHER PUBLICATIONS

Chihang Toys, Flier, Item #1062, "Combat Jeep".  
Wiring Flier, 1969, Item #37 "Cimimog 411".  
Sears Xmas Catalog, 1981, p. 626, Item #1, Toy "Jeep".

Primary Examiner—Charles A. Rademaker  
Attorney, Agent, or Firm—Amster, Rothstein & Engelberg

[57] CLAIM

The ornamental design for a toy vehicle, substantially as shown and described.

DESCRIPTION

FIG. 1 is a top plan view of a toy vehicle showing our new design;  
FIG. 2 is a front elevational view thereof;  
FIG. 3 is a right side elevational view thereof;  
FIG. 4 is a rear elevational view thereof;  
FIG. 5 is a bottom plan view thereof; and  
FIG. 6 is a left side elevational view thereof.

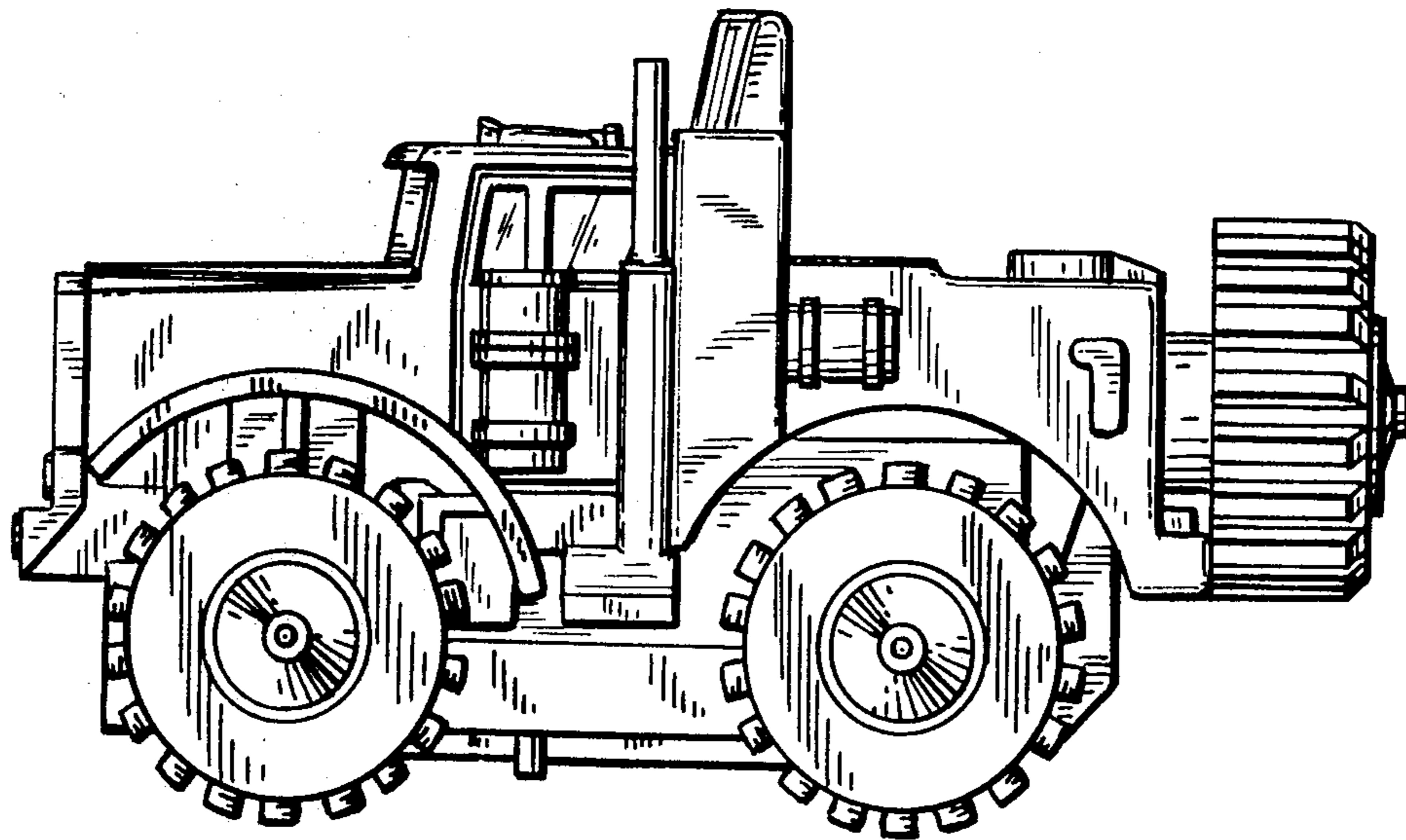

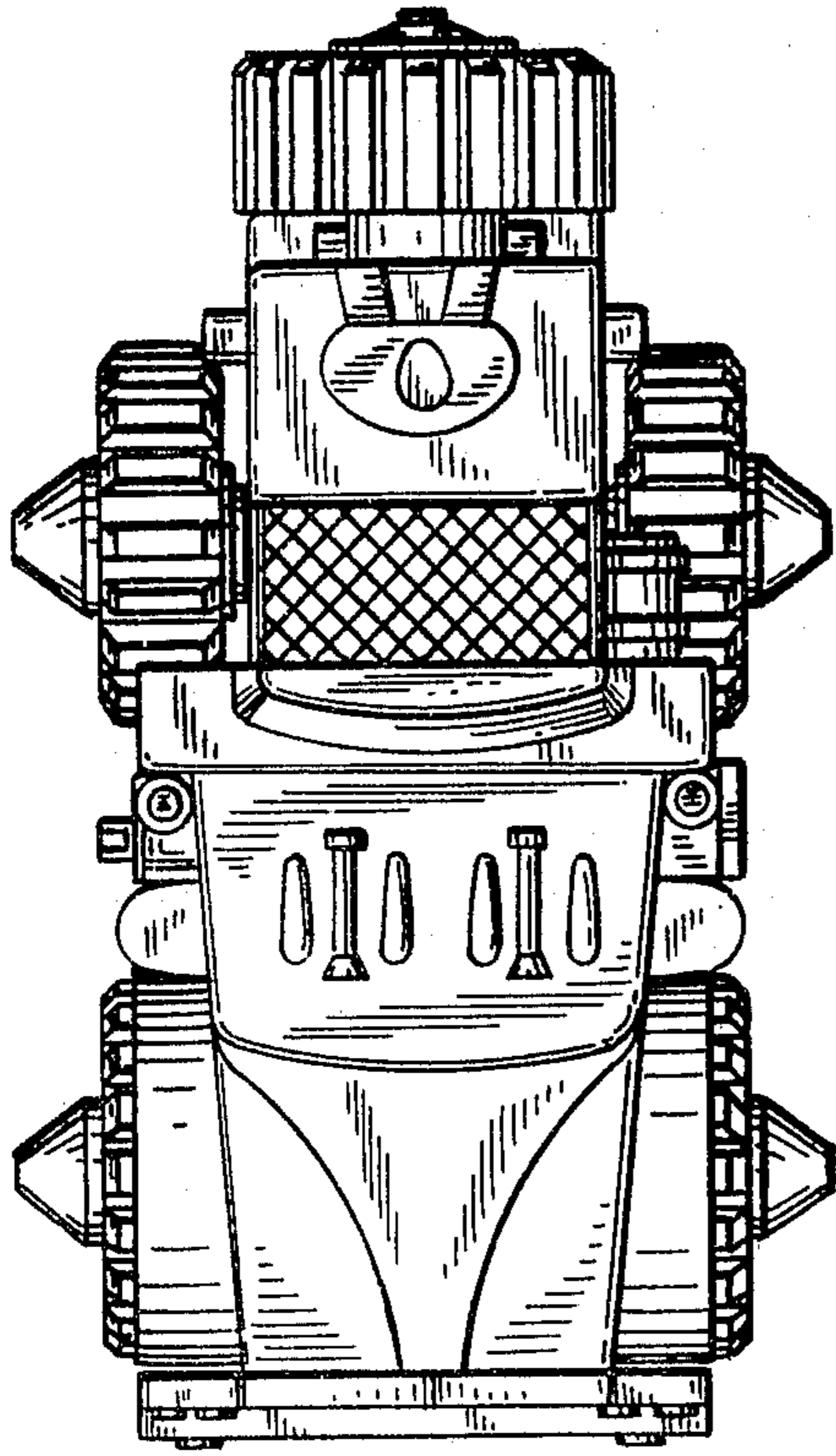

FIG. 1

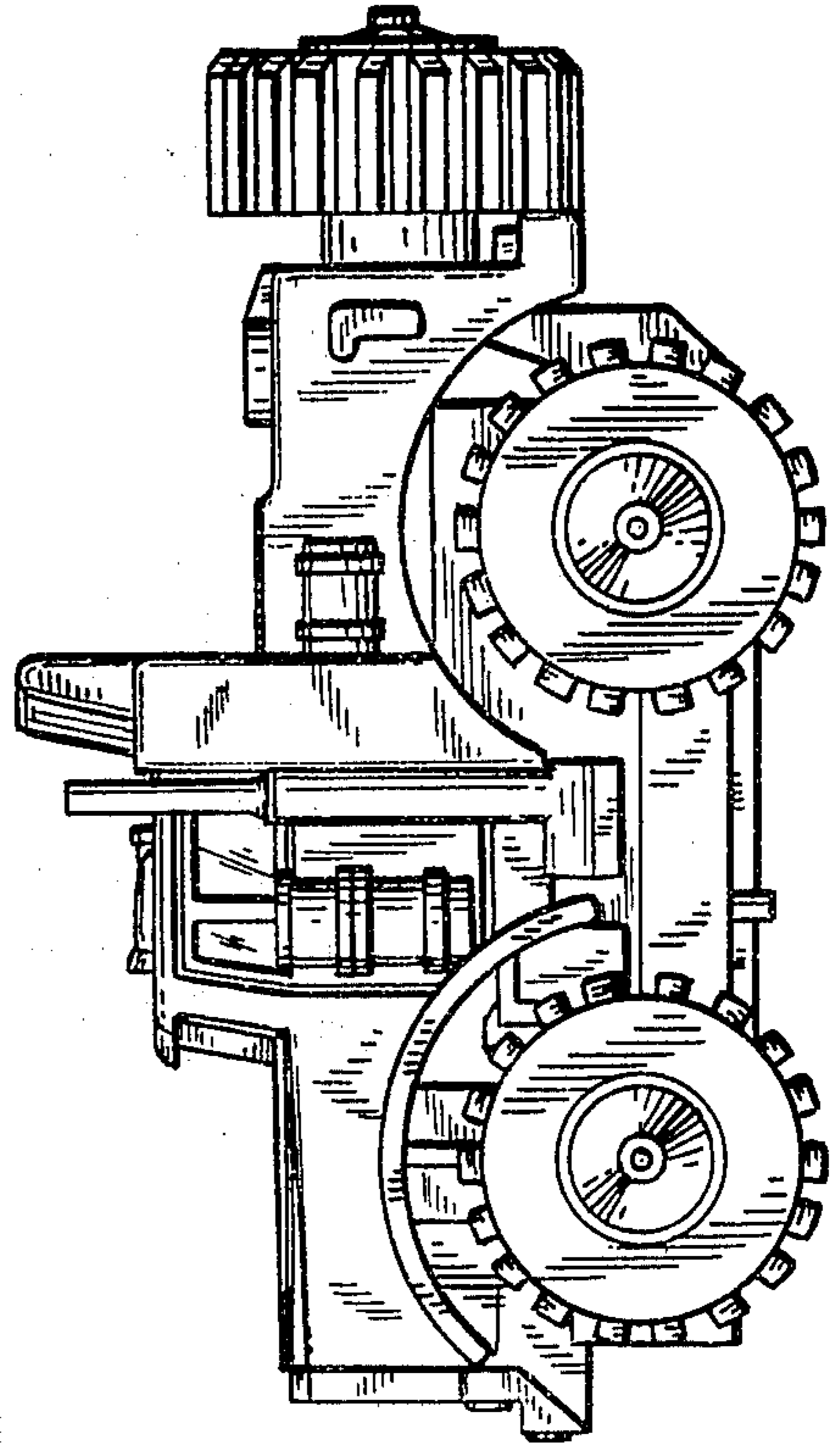

FIG. 3

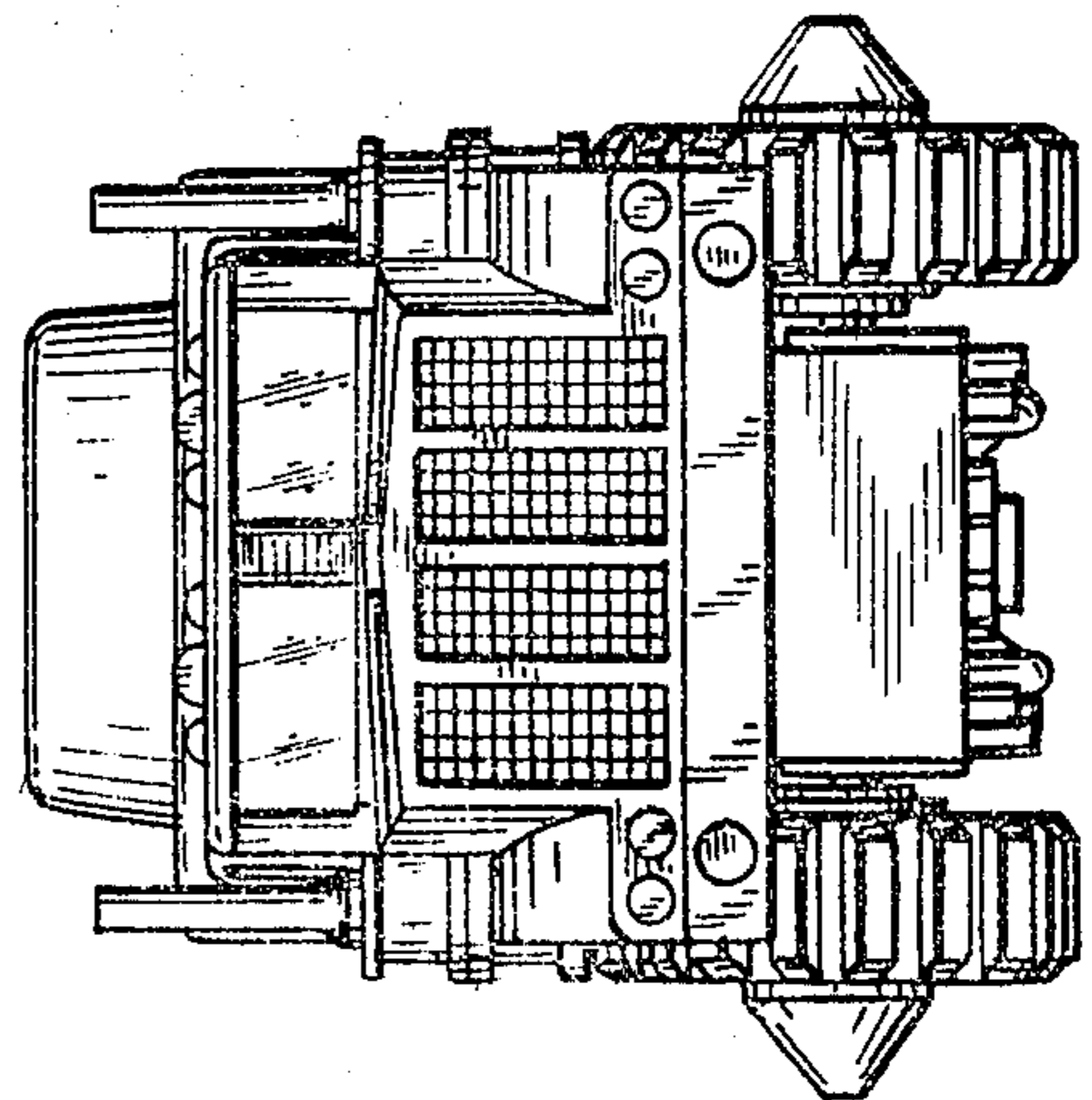

FIG. 2

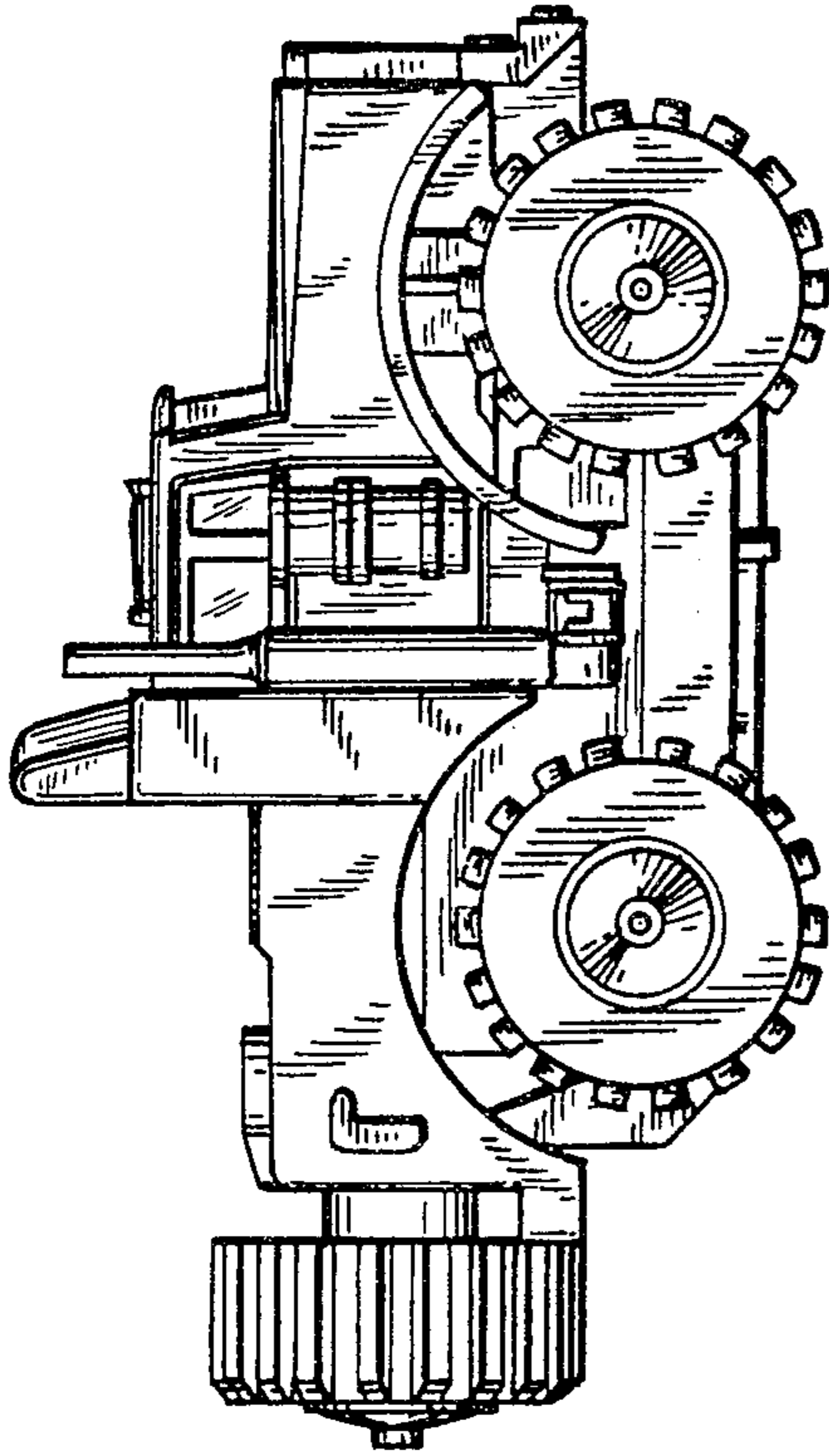

FIG. 4

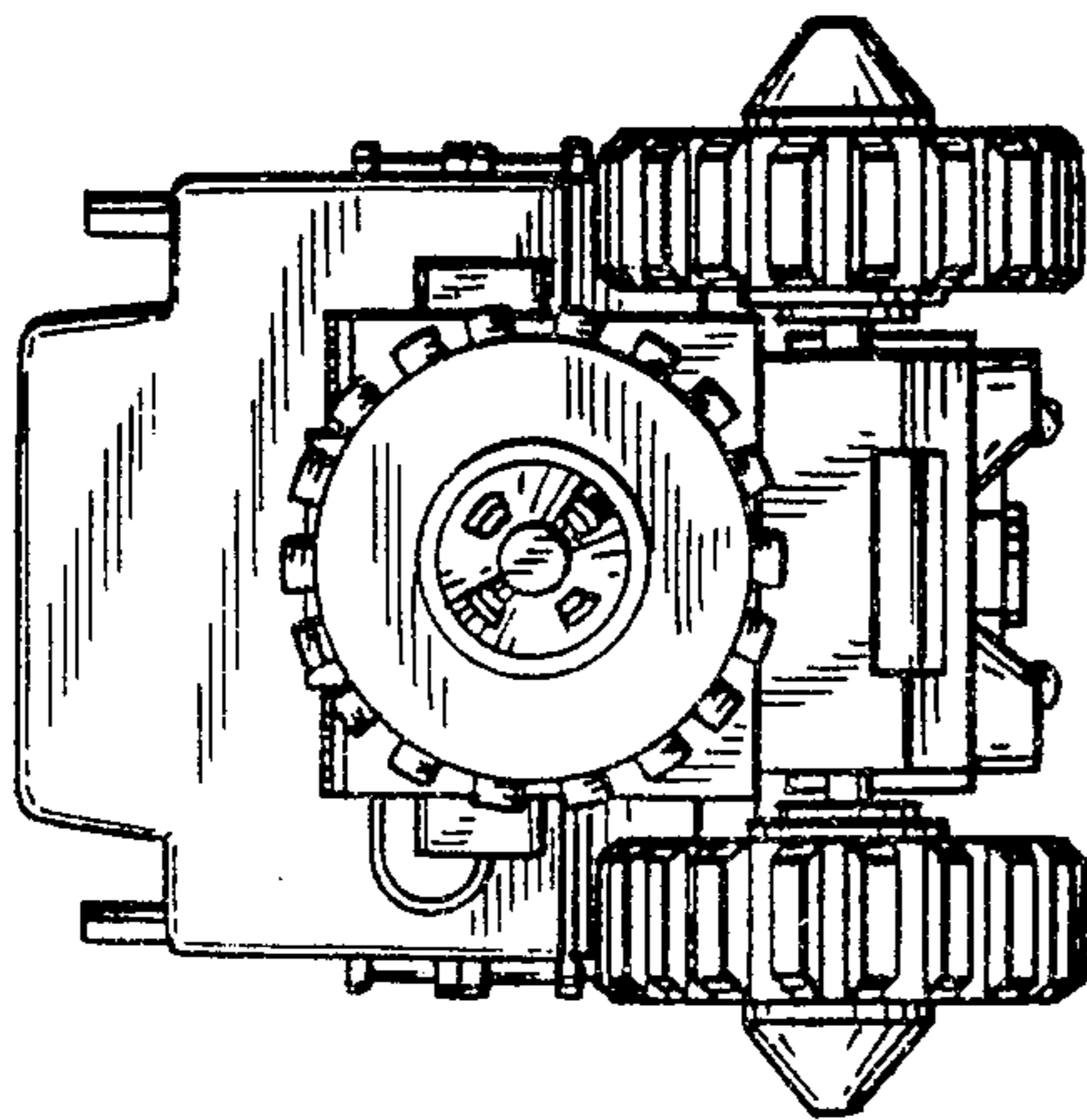

FIG. 5

FIG. 6

